

**AN OVERALL POLICY DECISION-SUPPORT SYSTEM FOR
EDUCATIONAL FACILITIES MANAGEMENT:
AN AGENT-BASED APPROACH**

by

Haya Bader Albader

A Dissertation

Submitted to the Faculty of Purdue University

In Partial Fulfillment of the Requirements for the degree of

Doctor of Philosophy



Lyles School of Civil Engineering

West Lafayette, Indiana

August 2018

ProQuest Number: 10843930

All rights reserved

INFORMATION TO ALL USERS

The quality of this reproduction is dependent upon the quality of the copy submitted.

In the unlikely event that the author did not send a complete manuscript and there are missing pages, these will be noted. Also, if material had to be removed, a note will indicate the deletion.



ProQuest 10843930

Published by ProQuest LLC (2018). Copyright of the Dissertation is held by the Author.

All rights reserved.

This work is protected against unauthorized copying under Title 17, United States Code
Microform Edition © ProQuest LLC.

ProQuest LLC.
789 East Eisenhower Parkway
P.O. Box 1346
Ann Arbor, MI 48106 – 1346

**THE PURDUE UNIVERSITY GRADUATE SCHOOL
STATEMENT OF COMMITTEE APPROVAL**

Dr. Amr Kandil, Chair

Lyles School of Civil Engineering

Dr. Hubo Cai

Lyles School of Civil Engineering

Dr. William Horton

Lyles School of Civil Engineering

Dr. William Mcinerney

College of Education

Approved by:

Dr. Dulcy Abraham

Head of the Graduate Program

To My Family

ACKNOWLEDGMENTS

My uppermost gratitude goes to the Lord, Allah Almighty, for all the blessings He bestowed on me to enable me to successfully finish this dissertation.

I would like to express the deepest appreciation to my major professor, Dr. Amr Kandil, for his mentorship and support. I also acknowledge the guidance and support of my committee members: Dr. Hubo Cai, Dr. William Horton, and Dr. William Mcinerney. I was honored to have such exceptional professors in my committee.

I am also thankful for my beloved family, friends, and all the people who supported and encouraged me during my doctoral research.

TABLE OF CONTENTS

TABLE OF CONTENTS	v
LIST OF TABLES	x
LIST OF FIGURES	xiii
ABBREVIATIONS	xvi
ABSTRACT	xviii
CHAPTER 1. INTRODUCTION	1
1.1 Overview & Background	1
1.2 Problem Statement.....	2
1.3 Research Objectives	2
Objective 1	2
Objective 2	3
Objective 3	3
1.4 Research Methodology	3
1.4.1 Task 1: Conduct a Comprehensive Literature Review	3
1.4.2 Task 2: Develop an Overall Deterioration Modeling Methodology for Educational Facilities.....	4
1.4.3 Task 3: Develop a Tactical Level ABS Model for Classroom Interactions	4
1.4.4 Task 4: Develop a Strategic Level ABS Model for Maintenance Policy Selection	5
1.5 Research Significance.....	5
1.6 Report Organization	6
CHAPTER 2. REVIEW OF THE LITERATURE	8
2.1 Overview.....	8
2.2 Educational Infrastructure: Current Dilemma.....	9
2.2.1 U.S. Schools' Condition and Age	9
2.2.2 Financial Crisis and Education Budget Cuts.....	11
2.3. School Facility Conditions and Student Performance	13
2.3.1 Overview	13
2.3.2. Studies Investigating the Relation Between School Physical Condition And Student Performance	13

2.3.3	Studies Investigating the Relation Between School Building Systems and Student Performance	19
2.3.3.1	Thermal Comfort and Indoor Air Quality	19
2.3.3.2	Lighting	20
2.3.3.3	Acoustical System.....	20
2.3.3.4	Overcrowding	20
2.3.3.5	School Age	20
2.4	Educational Facilities Asset Management	21
2.4.1	School Facility Condition Assessment	24
2.4.1.1	Educational perspective.....	25
2.4.1.1.1	Commonwealth Assessment of Physical Environment (CAPE)	26
2.4.1.1.2	The Guide for School Facility Appraisal Instrument (CEFPI) Instrument	30
2.4.1.1.3	Total Learning Environment Assessment (TLEA)	30
2.4.1.1.4	School Environment Suitability Assessment (SESA)	31
2.4.1.2	Engineering Perspective	32
2.4.1.2.1	Total Building Condition Evaluation (TOTSBA).....	32
2.4.1.2.2	School Facility Evaluation Project (SFEP)/Facility Quality Index Survey (FQI)	33
2.4.1.3	Educational Facilities Condition Assessment – The Practice	35
2.4.1.3.1	Facility Condition Index (FCI)	35
2.5	Agent Based Modeling (ABM).....	38
2.5.1	An Overview of Agent Based Modeling.....	39
2.5.2	Agent-Based Modeling (ABM) for Asset Management	40
CHAPTER 3. AN OVERALL EDUCATIONAL FACILITIES DETERIORATION CURVE: A THREE-STAGE PREDICTION MODEL		44
3.1	Overview.....	44
3.2	Deterioration Modeling	45
3.2.1	Deterministic Models	45
3.2.2	Stochastic Models	45
3.2.3	Artificial Intelligence Models.....	46

3.3	Markov Chain Condition Prediction Modeling.....	47
3.4	Conceptual Methodology.....	49
3.5	Results and Discussion	51
3.5.1	Stage 1: Identify the Overall Deterioration Pattern of Educational Facilities.....	51
	Task 1: Data Collection	52
	Task 2: Data Preparation.....	52
	Task 3: Transition Matrix Computation	53
	Task 4: Future States Probabilities Plotting.....	56
	Task 5: Deterioration Curve Plotting.....	57
	Task 6: Deterioration Curve Validation	59
	Task 7: Deterioration Curve Pattern Recognition	59
3.5.2	Stage 2: Determine the Average Useful Service-Life of Educational Facilities	61
	Task 1: Identifying School Building Systems/Components Percentages.....	61
	Task 2: Estimating School Building Systems/Components Average Nominal Life.....	70
3.5.3	Stage 3: Determine Deterioration Rate Boundaries for Educational Facilities	72
	Task 1: Develop an Overall Deterioration Model for Educational Facilities	72
	Task 2: Analyze and Simplify the Resulted Curve Through Linear Regression and Defining Range	73
3.6	Summary.....	75
CHAPTER 4. AGENT-BASED TACTICAL DECISION-SUPPORT SYSTEM FOR EDUCATIONAL FACILITIES MANAGEMENT: CLASSROOM INTERACTIONS MODELING		
		76
4.1	Overview.....	76
4.2	Introduction.....	78
4.3	Background	79
4.3.1	The Classroom Indoor Environment: The Silent Curriculum	79
4.3.2	HVAC Systems:.....	91
4.3.2.1	Overview of HVAC Systems.....	91
4.3.2.2	HVAC System Maintenance and Energy Consumption	93
4.4.	System of Systems (SoS) Modeling Approach and Methodology.....	95
4.4.1	Tactical Level ABM Definition Phase:.....	96

4.4.2	Tactical Level ABM Abstraction Phase:.....	100
4.4.2.1	Tactical Level Conceptual Model (Paper Model).....	100
4.4.2.2	Tactical Level Stakeholders.....	101
	HVAC System:.....	102
	Student Agent:.....	104
	Teacher Agent	105
	Classroom Agent	106
	Facility Management Department (FMD) Agent.....	107
	School Administration Agent.....	108
	Parents Agent	109
4.4.3	Implementation Phase	110
4.4.3.1	Agents Implementation & Dynamics.....	110
4.4.3.1.1	Students Agent	110
4.4.3.1.2	HVAC System Agent	122
4.4.3.1.3	Classroom Agent.....	129
4.4.3.1.4	Facility Management Department (FMD) Agent.....	130
4.4.3.1.5	School Administration Agent	132
4.4.3.1.6	Parents Agent	132
4.4.3.1.7	Teachers Agent	133
4.5	Model Validation and Verification.....	144
4.6	Summary	147
CHAPTER 5. AGENT-BASED STRATEGIC DECISION-SUPPORT SYSTEM FOR		
EDUCATIONAL FACILITIES MANAGEMENT: MAINTENANCE BUDGET		
	ALLOCATION MODELING	148
5.1	Overview	148
5.1	Introduction.....	149
5.1.1	Problem Overview	149
5.1.2	School Facilities Condition and Student Achievement Theoretical Model	150
5.2	System of Systems (SoS) Modeling Approach and Methodology.....	151
5.2.1	Definition Phase.....	151
5.2.2	Abstraction Phase.....	155

5.2.2.1	Strategic Level Conceptual Model (Paper Model)	155
5.2.2.2	Agents Definitions and Interactions.....	156
	Student Agent (Beta Level).....	157
	Parent Agent (Beta Level).....	158
	Teacher Agent (Beta Level)	158
	Principal Agent (Beta Level)	158
	School Facilities Agent (Beta Level).....	158
	School District Agent (Gamma Level).....	159
5.2.3	Implementation Phase	159
5.2.3.1	Agents Implementation & Dynamics	159
	Student Agent (Beta Level).....	159
	Parents Agent (Beta Level)	162
	Teacher Agent (Beta Level)	163
	School Facilities Agent (Beta Level).....	164
	School Principal Agent (Beta Level).....	168
	School District Agent (Gamma Level)	171
5.2.3.2	Model Execution and Simulation Case Study	175
5.3	Model Verification and Validation.....	186
5.4	Summary	187
CHAPTER 6. SUMMARY AND CONCLUSIONS		188
6.1.	Conclusions	188
6.2.	Research Contribution	191
6.3.	Future Research.....	191
REFERENCES		192
VITA		221

LIST OF TABLES

Table 2.1	Studies Indicating Significant and Non-Significant Relationships Between School Building Conditions and Student Performance from 1987 to 2008	16
Table 2.2	Summary of the Studies that Examined the Relations Between School Building Conditions and Student Performance	17
Table 2.3	Studies Indicating Significant and Non-Significant Relationships Between School Building Components and Student Performance from 1987 to 2008	22
Table 2.4	Structural and Cosmetic Items on the Commonwealth Assessment of Physical Environment (CAPE) As Created by Cash (1993).....	28
Table 2.5	Studies That Used CAPE-Based Evaluation Tools to Determine Building Conditions	29
Table 2.6	Studies That Used CAPE Hybrid Evaluation Tools to Determine Building Conditions	29
Table 2.7	Main Categories of the CEFPI Guide for School Facility Appraisal, 1998 Edition	30
Table 2.8	Categories of School Environment Suitability Assessment (SESA)	31
Table 2.9	Total Building Condition Evaluation Component and Sub-Component	33
Table 2.10	School Facility Evaluation Project (SFEP) Categories	34
Table 2.11	Facilities Condition Metrics	36
Table 2.12	FCI Scale Guidelines.....	36
Table 2.13	Educational Facilities Condition Assessment Database System	38
Table 2.14	Summary of ABM Studies for Asset Management	43
Table 3.1	Summary of Prince George's County Public Schools (PGCPS) Data	52
Table 3.2	Transition Matrix for Five Equal Intervals Case (Dataset 1)	54
Table 3.3	Transition Matrix for FCI Guidelines Three States Case (Dataset 1)	54
Table 3.4	Transition Matrix for Five Equal Intervals Case (Dataset 2)	55

Table 3.5	Transition Matrix for FCI Guidelines Three States Case (Dataset 2)	55
Table 3.6	ASTM Unifomat II Classification for Building Elements	62
Table 3.7	UNIFORMAT II to MAPPS Conversion.....	63
Table 3.8	School Districts Used for Developing Building Systems' Percentages Distribution	67
Table 3.9	MAPPS Systems Distribution Percentages	68
Table 3.10	Converted UNIFORMAT II Distribution Percentages	69
Table 3.11	Average School Facility's System Percentage	70
Table 3.12	Average Educational Facility Deterioration Rate	73
Table 4.1	Summary of the Studies that Examined the Relations Between Classroom Ventilation and Student Performance.....	84
Table 4.2	Summary of the Studies that Examined the Relations Between Classroom Temperature and Student Performance	84
Table 4.3	Summary of the Studies that Examined the Relations Between the Classroom IEQ Variables and Student Health.....	85
Table 4.4	Summary of the Studies that Examined the Relations Between the Classroom IEQ Variables and Student Satisfaction.....	85
Table 4.5	Summary of the Studies that Examined the Relations Between the Classroom IEQ Variables and Student Performance, Health, And Satisfaction	86
Table 4.6	Summary of the Studies That Examined the Relations Between IEQ and Employee Performance	89
Table 4.7	Summary of the Studies That Examined the Relations Between IEQ and Employee Health.....	90
Table 4.8	Summary of the Studies That Examined the Relations Between IEQ and Employee Satisfaction.....	90
Table 4.9	Summary of the Studies That Examined the Relations Between IEQ and Employee Behavior.....	90
Table 4.10	ASTM Unifomat II Classification for the HVAC System.....	91

Table 4.11 HVAC System Configuration.....	92
Table 4.12 Wang & Hong (2013) HVAC Maintenance Practices Types.....	95
Table 4.13 Tactical-Level Model Lexicon and Scope.....	99
Table 4.14 Perception Model Results for Different Satisfaction Values	122
Table 4.15 HVAC Components Deterioration Rates	127
Table 4.16 School Prototype Information	133
Table 4.17 HVAC System Description	135
Table 4.18 HVAC System Total Cost	135
Table 4.19 HVAC System Used for the Simulation	135
Table 4.20 Case Study Budget Information.....	136
Table 4.21 Model Results at the End of the Simulation.....	144
Table 5.1 New Schools' Information Based on 20th Annual School Construction Report	164
Table 5.2 Condition Index (CI) Interpretation	165
Table 5.3 Available Facility Assessment Reports Created by MAPPS System	169
Table 5.4 Priorities 1 To 5 – Maintenance Needs Per Building Systems as Percentage.....	170
Table 5.5 Priorities 1 To 5 – Maintenance Needs Per Building Systems as USD.....	170

LIST OF FIGURES

Figure 1.1	Research Methodology	7
Figure 2.1	General View of the Literature Review Map	8
Figure 2.2	Literature Review Map for Educational Infrastructure Current Dilemma	9
Figure 2.3	Literature Review Map for Educational Facilities Assets Management	21
Figure 2.4	Condition Assessment Approaches	25
Figure 2.5	Literature Review Map for Agent Based Modeling (ABM)	39
Figure 2.6	Agents and Interactions in Pavement Network Management Model	42
Figure 3.1	Deterioration Models	47
Figure 3.2	Markov State Chart and Transition Matrix for Three States Deterioration	48
Figure 3.3	Condition Prediction Modeling Conceptual Methodology	51
Figure 3.4	Markov Chain Condition Prediction Methodology	53
Figure 3.5	Markov Chain State Chart (Dataset 1: 2001 – 2008)	54
Figure 3.6	Markov Chain State Chart (Dataset 2: 2008 – 2012)	55
Figure 3.7	Relation Between Time and the Probabilities of Each State (Dataset 1)	56
Figure 3.8	Relation Between Time and the Probabilities of Each State (Dataset 2)	57
Figure 3.9	Markov Chain Deterioration Curves	58
Figure 3.10	Markov Chain Deterioration Curves for the Two Datasets	60
Figure 3.11	Simplified Overall School Facilities Deterioration Pattern Plot	60
Figure 3.12	School Facility's Systems Weighted Average Life Expectancy Plots	72
Figure. 3.13	Overall Educational Facility Deterioration Curve	74
Figure. 3.14	Simplified Educational Facility Deterioration Curve	75
Figure 4.1	Tactical Level ABM Mind Map	77

Figure 4.2	IEQ Factors and Measurements	81
Figure 4.3	Human Factors Studied in the IEQ Research	83
Figure 4.4	The HVAC System Used in the Research	93
Figure 4.5	Proto-Method Methodology	96
Figure 4.6	Cause and Effect Diagram Analyzing Causes for Poor Indoor thermal and Air Quality in the Classroom Environment	98
Figure 4.7	Tactical Level Conceptual Model	101
Figure 4.8	Agents' Attributes and Interactions in the Tactical Level Model	102
Figure 4.9	HVAC System Agent Attributes and Interactions	103
Figure 4.10	Student Agent Attributes and Interactions	105
Figure 4.11	Teacher Agent Attributes and Interactions	106
Figure 4.12	Classroom Agent Attributes and Interactions	107
Figure 4.13	FMD Agent Attributes and Interactions	108
Figure 4.14	School Administration agent Attributes and Interactions	109
Figure 4.15	Parents Agent Attributes and Interactions	109
Figure 4.16	General UML Class Diagram	111
Figure 4.17	HVAC System UML Class Diagram	112
Figure 4.18	Agents Implementation Section Mind Map	113
Figure 4.19	HVAC System, Classroom, and Student Agents Interactions	114
Figure 4.20	Students' Social Network	115
Figure 4.21	Level 1 of IEQ Satisfaction Fuzzy Logic	117
Figure 4.22	Level 2 of IEQ Satisfaction Fuzzy Logic	119
Figure 4.23	HVAC Agent Structure	123

Figure 4.24 FCU Component Status Interpretation	125
Figure 4.25 HVAC Deterioration Pattern & Its Relation to Failure Probability	125
Figure 4.26 HVAC Component Deterioration Pattern	126
Figure 4.27 HVAC System Failure Magnitude Used in the Simulation	128
Figure 4.28 Classroom IEQ Attributes Value Interpretation	130
Figure 4.29 HVAC System Failures Prioritization Model	131
Figure 4.30 Simulation Timeline	134
Figure 4.31 Simulation User Interface	137
Figure 4.32 Simulation Process	138
Figure 4.33 Simulation Main Interface	139
Figure 4.34 Main Results at the End of the Simulation	140
Figure 4.35 Reactive and Preventive Maintenance Results for Classroom at the end of the Simulation	142
Figure 4.36 Reactive and Preventive Maintenance Results for HVAC Component at the End of the Simulation	143
Figure 4.37 Color Coding Used in the Simulation Visualization	145
Figure 4.38 Code Verification Using Print Command to Check Results During Exclusion	146
Figure 5.1 Strategic Level ABM Mind Map	149
Figure 5.2 Public Education Operating Budget Cycle	153
Figure 5.3 The Budget Dilemma of Public Education	153
Figure 5.4 Strategic Model Boundaries	154
Figure 5.5 Strategic Level Conceptual Model	156
Figure 5.6 Agent Attributes and Interactions	157
Figure 5.7 UML Class Diagram	160

Figure 5.8	Facility Deterioration Curve	166
Figure 5.9	Austin Independent School District FCI Vs. Age Relationship	167
Figure 5.10	OLF and UF Relationship	167
Figure 5.11	Budget Allocation Possible Scenarios	175
Figure 5.12	Strategic Level Agent-Based Model Simulation Process	177
Figure 5.13	Input User Interface	178
Figure 5.14	Sample Results - Budget Factor = 5	178
Figure 5.15	Sample Results - Policy Comparison - Budget Factor = 1.5	179
Figure 5.16	Sample Results - Policy Comparison - Budget Factor = 3.5	180
Figure 5.17	Sample Results - Policy Comparison - Budget Factor = 5	181
Figure 5.18	Sample Results - Policy Comparison - Budget Factor = 6.5	182
Figure 5.19	Sample Results - School District - Budget Factor = 5	183
Figure 5.20	Sample Results - School 25 - Budget Factor = 5	184
Figure 5.21	Sample Results - School 35 - Budget Factor = 5	184
Figure 5.22	Sample Results - Budget Factor = 1.75	185
Figure 5.23	Sample Results – Single School- Budget Factor = 1.75	185
Figure 5.24	Sample Results – School District- Budget Factor = 1.75	186

ABBREVIATIONS

ABCCES	Assessment of Building and Classroom Conditions in Elementary Schools
ABM	Agent-Based Model
ABS	Agent-Based Simulation
AC	Acoustic Comfort
ACI	Asset Condition Index
APPA	Association of Higher Education Facilities Officers
ASCE	American Society of Civil Engineers
BCCI	Building Component Condition Index
BCI	Building Condition Index
CAPE	Commonwealth Assessment of Physical Facilities
CBPP	Center on Budget and Policy Priorities
CEFPI	Council of Educational Facility Planners International
CI	Condition Index
CRV	Current Replacement Value
CSCI	Component-Section Condition Index
FCI	Facility Condition Index
FCU	Fan-Coil Unit
FLS	Fuzzy Logic System
FM	Facility Management
FMD	Facility Management Department
FQI	Facility Quality Index
GAO	General Accounting Office
HSAP	High School Assessment Program
HVAC	Heating, Ventilation and Air Conditioning
IAQ	Indoor Air Quality
IEQ	Indoor Environmental Quality
ISTEP	Indiana Statewide Test for Educational Progress
LCC	Life Cycle Costs

MEEB	Model for The Evaluation of Educational Buildings
NACUBO	National Association of College and University Business Officers
NCES	National Center for Education Statistics
O&M	Operations and Maintenance
OLF	Overload Factor
PAQ	Perceived Air Quality
PMV	Predicted Mean Vote
PoF	Probability of Failure
PSSA	Pennsylvania System of School Assessment
RTF	Run to Failure Maintenance
SBS	Sick Building Syndrome
SCI	System Condition Index
SES	Socioeconomic Status
SESA	The School Environment Suitability Assessment
SFEP	School Facility Evaluation Project
SOS	System of Systems
SPEVA	Schools Physical Environment Variables Assessment
TC	Thermal Comfort
TCV	Thermal Comfort Vote
TDSB	Toronto District School Board
TLEA	Total Learning Environment Assessment
TOTSBA	Total Building Condition Evaluation
TPM	Markov Transition Probability Matrix
TSV	Thermal Sensation Vote
UF	Utilization Factor
UML	Unified Modeling Language
USGBC	U.S. Green Building Council
VC	Visual Comfort
VF	Vandalism Factor

ABSTRACT

Author: Albader, Haya, B. PhD

Institution: Purdue University

Degree Received: August 2018

Title: An Overall Policy Decision-Support System for Educational Facilities Management: An Agent-Based Approach.

Major Professor: Amr Kandil

Although K-12 public school facilities infrastructure investments are second only to highways, schools continue to suffer from an approximately \$38 billion annual funding gap. Massive reductions in funding are forcing school districts to make tough decisions to optimize maintenance expenditures. Over the last three decades, a huge body of research has determined that the condition of school facilities do affect student health and performance, and some have further demonstrated that schools are overwhelmed by deteriorating facilities that threaten the health, safety, and learning opportunities of students. The currently available educational facility management approaches oversee the influence of the complex and mutual interactions between a school facility and its occupants. This thesis aimed to develop an overall decision support system for decision-makers that promotes efficient planning and management of educational infrastructure system by embracing a proactive management style rather than reactive.

The proposed system consists of three main components: (1) an overall condition prediction model for educational facilities as a whole, (2) a tactical level Agent-based model (ABM) for classroom interaction simulation, and (3) a strategic level ABM for maintenance budget allocation. ABM was selected for its flexibility, natural representation of the problem, and suitability for modeling real-world complex systems with heterogenous agents.

The first tool was accomplished through the development of a three-stage condition prediction methodology. The first stage aims to recognize the deterioration pattern of the educational facility as a whole by utilizing a Markov chain modeling approach. The second stage focuses on determining the overall useful service life of educational facilities. The third stage identifies the higher and lower limits of the educational facilities' deterioration rate. The resulted model can help

decision-makers plan and forecast their maintenance needs and better manage the available resources. The proposed methodology can be applied to any multi-component asset.

The second tool, the tactical level decision support ABM, was developed to provide decision-makers with new insights into the effects of different maintenance policies on the educational system. The model simulates day-by-day classroom interactions and highlights the importance of preventive maintenance on the educational system's major stakeholders (agents).

The third decision support tool presented in this research is the strategic level model for testing the effects of different maintenance budget allocation strategies on the school district revenues, overall performance, enrollment size, and land values over years. ABM enhances the overall comprehension of the current situation and its complex relations, increases resource allocation efficiency, highlights the important factors affecting the system that are overlooked in traditional management styles, thereby improving the quality of educational outcomes.

The main challenge in developing the proposed ABM was identifying and quantifying the main stakeholders' complex interactions due to the uncertainties inherent in human behavior. This thesis demonstrated the need for a holistic bottom-top asset management modeling approach rather than asset-centric top-down approach. The case study results of this research confirmed that ABM has great potential as an asset management tool for decision-makers that can provide a comprehensive and holistic understanding of the system dynamics.

CHAPTER 1. INTRODUCTION

1.1 Overview & Background

The condition of a school's physical environment is a critical factor for the academic success and health of our children (Crampton et al, 2008). The impact of school facilities on student performance and health has been contested in the courts, of which the most famous was the case, filed in 2000, of Williams v. the State of California. Approximately 100 students from San Francisco County accused the state of failing to deliver "equal access to instructional materials, safe and decent school facilities, and qualified teachers" (California Department of Education, 2013). In 2004, the case was settled, and \$800 million was to be provided for critical repairs to facilities as a part of the settlement

In 1995, the U.S. General Accounting Office published a report titled "Condition of America's Schools", which mentioned that "A number of state courts as well as the Congress have recognized that a high-quality learning environment is essential to educating the nation's children. Crucial to establishing that learning environment is that children attend school in decent facilities."

According to the National Center for Education Statistics, there were 13,924 public school districts with 98,916 operating public schools housing more than 48 million students during the 2007–2008 school year (Hoffman, 2009). Unfortunately, the condition of school infrastructure was given an overall grade of "D" in the American Society of Civil Engineers (ASCE) 2013 Report Card. In their report, ASCE indicated that more than \$270 billion are needed for public schools' necessary maintenance and renovation. The relation between the condition of school buildings and its effects on student and teacher performance has been extensively studied during the last few decades. Hundreds of research projects were reviewed by four synthesis studies conducted by Weinstein (1979), McGuffey (1982), Lemasters (1997), and Bailey (2009). Bailey concluded that "The results of the previous three syntheses in 1979, 1982, and 1997, along with the results of the findings in this study, supported and indicated that building condition was directly related to student achievement, student behavior, and student attitude." A comprehensive review is presented in the literature review section of this dissertation.

1.2 Problem Statement

Hundreds of billions of dollars have been spent on school infrastructure in an attempt to create a safe and suitable environment where children can learn and be ready for their future challenges. Nevertheless, according to the 2017 ASCE Report Card, U.S. school infrastructure is in a poor condition and a major investment is needed to bring schools to an operable condition. With the financial crisis that is sweeping the U.S., several local governments are facing serious budget deficiencies and critically need an overall policy decision-support system to help them select the best budget allocation policy to achieve the best possible results with limited resources. Existing educational facilities management methods do not take into consideration student outcomes. The condition of school facilities can have an enormous influence on the morale, behavior, and performance of both teachers and students. In order for decision-makers to select the best facilities improvements alternative, it would be wise to consider the long-term effects on all major stakeholders in the facilities, especially students. Therefore, the purpose of this study is to develop a decision-support tool specific to the domain of educational facilities maintenance management that can support school district decision-makers in selecting the most beneficial strategy with a focus on the educational outcomes.

1.3 Research Objectives

The main objective of this research is to create an effective tool/method to help education facilities decision-makers in selecting the best policy for their specific budget allocations that will aim to maximize student achievement. To achieve this, the study questions and objectives are as follows:

Objective 1

- The first objective is to develop a deterioration model for school facilities as a whole using facility condition index (FCI) assessment data. The developed deterioration model can be used to calculate the needed maintenance budget.
- Research question: How does the condition of school buildings change with time? How the different building systems/components condition change with time?
- Product: A time-dependent deterioration model for educational facilities as a whole.

Objective 2

- The second objective is to understand and model classroom complex dynamic relations/interactions on the tactical level.
- Research questions: What are the dynamic interactions between school facilities and student performance? How do the relations/interactions between classroom environment; student behavior (e.g. performance, aggression, and health); teacher performance; and parent involvement affect each other?
- Product: Tactical level agent-based simulation (ABS) model to test the direct and indirect effects of the classroom environment on student performance and vice versa.

Objective 3

- The third objective is to understand and model the complex relations/interactions between school facility deterioration, student achievement, levels of funding, and the decisions of policy-makers on the strategic level.
- Research Question 3: Do different maintenance budget allocation policies have different effects on the condition of school facilities and student performance? Is there a relation between the facility condition and the maintenance prioritization for educational facilities? Can we examine how educational facilities maintenance deficiencies may be divided into different priority levels?
- Product: Strategic level ABS model for testing the effect of different budget allocation strategies.

1.4 Research Methodology

In order to achieve the research objectives, the research work is organized into the following four main research tasks, which also are shown in Figure 1.1:

1.4.1 Task 1: Conduct a Comprehensive Literature Review

This task involves the following sub-tasks:

1. Investigate the current dilemma between the poor conditions of educational facilities on the one hand and limited budgets on the other.

2. Examine the relationship between the condition of school facilities and student performance.
3. Examine the current literature pertaining to educational facilities asset management and condition assessment research and practices to determine the possible research gaps.
4. Explore and identify the potential of ABS as a modeling technique for asset management systems.

1.4.2 Task 2: Develop an Overall Deterioration Modeling Methodology for Educational Facilities

The purpose of this task is to develop a modeling methodology for predicting educational facilities deterioration. The research work in this task can be divided into the following sub-tasks:

1. Review the current deterioration modeling techniques and identify the most suitable technique for the present research.
2. Examine the available school facilities condition assessment data and methods.
3. Develop a modeling methodology to predict the overall educational facilities condition.
4. Test the proposed methodology using case study data and creating an overall deterioration model for school facilities.
5. Evaluate the developed model.

1.4.3 Task 3: Develop a Tactical Level ABS Model for Classroom Interactions

This task involves the development of a day-by-day tactical level ABS model for the complex interactions between the classrooms and the students in the case of HVAC maintenance deficiencies. The research work in this task can be divided into the following sub-tasks:

1. Define the HVAC system functions in the classroom context. (e.g. Thermal control and air quality).
2. Examine the impact of HVAC system on students. This can be achieved by investigating the psychological, physiological, and social impacts of HVAC system failures.
3. Explore the factors affecting student performance, which include personal, environmental, peers, teachers, and parents.
4. Develop the ABS model using System of Systems (SOS) Proto-method.

1.4.4 Task 4: Develop a Strategic Level ABS Model for Maintenance Policy Selection

Create a decision-support tool prototype by developing a macro strategic level ABS model to study the effects of different maintenance budget allocation policies on student performance. This task can be divided into the following sub-tasks:

1. Review the theoretical models examining the school facility condition and student performance relationship.
2. Understanding the dynamics behind educational facilities maintenance financing.
3. Determine the strategic level major stakeholders and the goals that will shape their behavior.
4. Define maintenance budget allocation strategies to be tested by the model.
5. Develop and evaluate the strategic level ABS model.

Tasks 3 and 4 follow the same SOS Proto-method that is normally used for developing an ABS model. The process composed of three phases and can be summarized as follows:

- 1- Definition phase: aims to understand the current problem.
- 2- Abstraction Phase: aims to build the conceptual model based on literature review, theories, common knowledge, and/or empirical data. Then, translating the conceptual model into ABM by defining the agents and their attributes, the rules that govern agent interaction and the environment where the agents reside.
- 3- Implementation phase: Starts with developing the software and implementing the model. In addition to model validation and verification.

1.5 Research Significance

The current professional evaluation models for education facilities used in practice concentrate on the engineering and energy perspectives and overlook the perceptions and effects on the stakeholders of the facilities (Roberts 2009, Flygt 2009, and Dorris 2011). Roberts (2009) argued that taking the functional purposes of educational facilities into consideration is extremely important when evaluating the condition of school building and selecting maintenance strategies. The author measured the school facilities condition in two ways: engineering assessments and questionnaire assessments by school principals. Later, the condition data from both assessments were correlated with each school's quality of teaching and learning environments (QTLE). The

researcher found that the engineering assessments were not related to the QTLE scores while the educators' assessments were. Roberts concluded that "The findings indicate that more research needs to be directed at developing sound tools for measuring school facilities in terms of their educational relevance. In addition, school administrators need to reconsider policies that devalue the contribution that facilities make to learning outcomes." (Roberts, 2009).

This study aims to address the limitations of the current assets management practices of educational facilities that overlook the impact of the complex interaction between students and educational facilities. In addition, it will also address the lack of decision- support tools and simulations that support decision-makers at school districts in selecting the best maintenance intervention strategy to maximize student performance. This study will introduce a new simulation approach using agent-based modeling (ABM) that can capture the complex real-world relations in the school environment.

1.6 Report Organization

This report consists of six chapters. Chapter 1 is the introduction and includes background information, problem definition and its significance, main research objectives and expected output, and, lastly, the methodology to achieve the research objectives. Chapter 2 presents the related literature review, which is divided into three main parts. The first part deals with the motivation behind the research topic selection and discusses the current dilemma for educational facilities of poor conditions and limited budgets. It also presents past research that investigated the relation between student performance and the condition of a school building. The second part deals with the research conducted in the area of educational facilities assets management with a focus on school condition assessment methods. The last part provides background information on ABS modeling that is used on the micro and macro levels in the current research. Chapter 3 will propose the methodology for developing an overall educational facilities deterioration curve using a three-stage prediction model and chapter 4 and 5 will discuss the development and implementation of the tactical and strategic level ABS models for testing maintenance types and budgets policies effects on students' outcomes.

Lastly, Chapter 6 will summarize the dissertation and highlights the research contribution and future research directions.

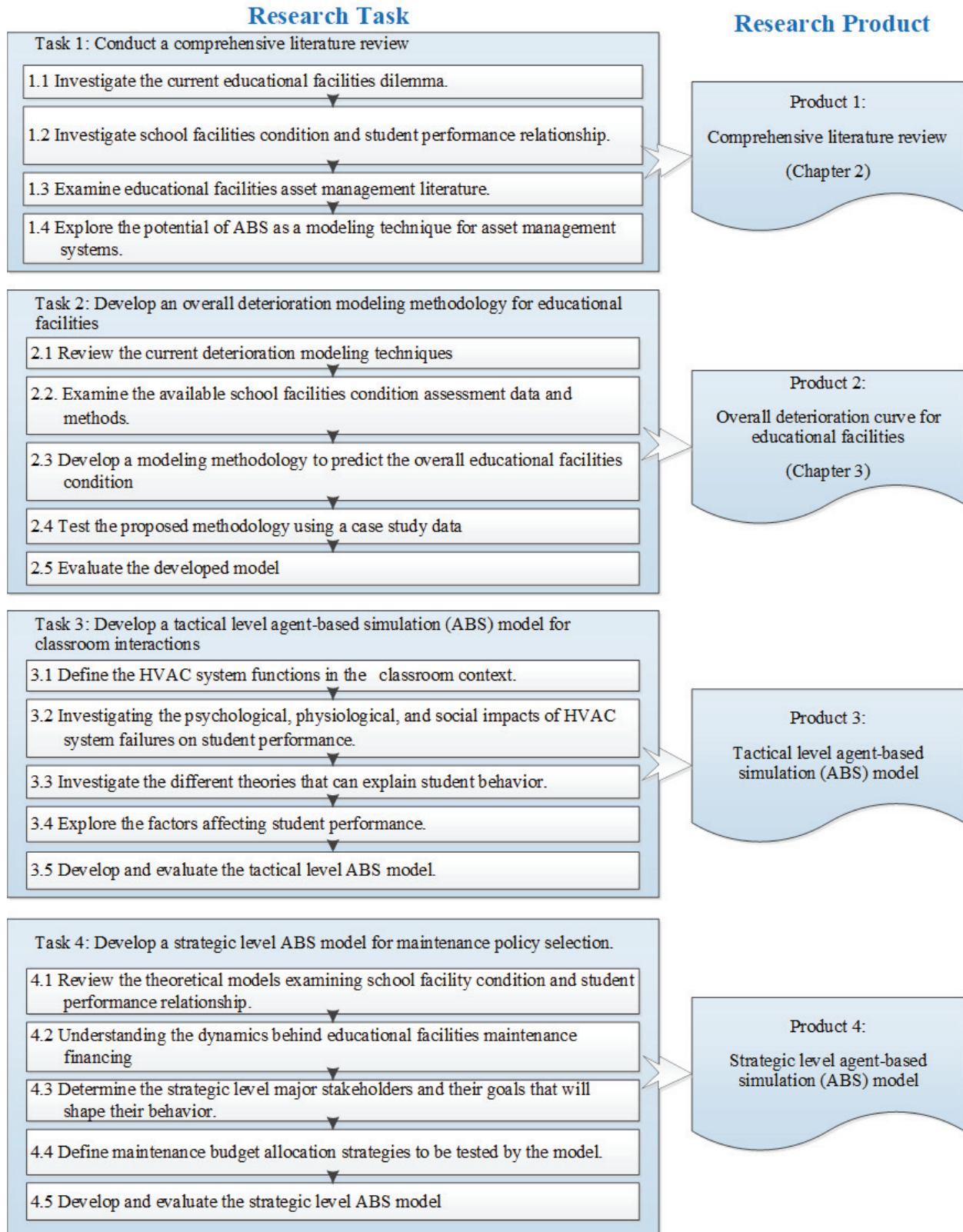

Figure 1.1 Research Methodology

CHAPTER 2. REVIEW OF THE LITERATURE

2.1 Overview

Chapter 2 presents a comprehensive literature review of the recent research efforts related to our research topic. Figure 2.1 illustrate the chapter map. As shown in the figure below, the literature review is divided into three main parts: The first part looks at the motivation and importance of the research topic. It examines the literature related to the current challenges faced by education infrastructure in the U.S. It also shows the influence of the physical environment of a school on its occupants. The effect that school building conditions have on student academic performance is illustrated by a review of the studies in that area since the early 1990s.

The second part in this chapter examines the research done in the area of educational facilities assets management area. A comprehensive review of the different condition assessment methods used to evaluate the condition of school buildings is presented in this part.

The third part introduces Agent-based simulation (ABS) which will be used as a simulation tool in the current research.

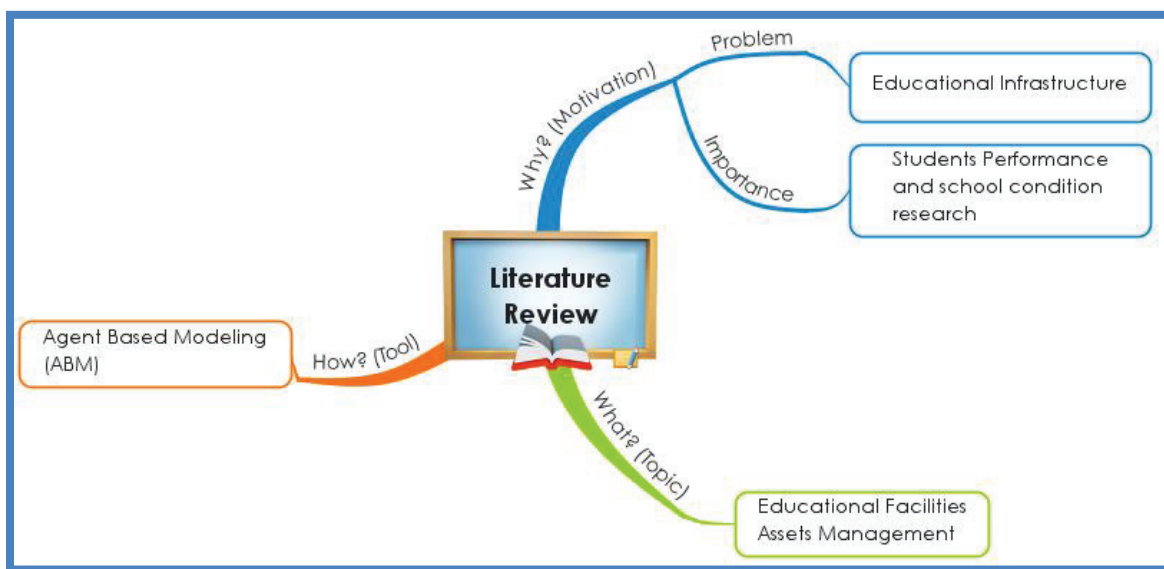

Figure 2.1 General View of the Literature Review Map

2.2 Educational Infrastructure: Current Dilemma

Educational facilities are a major component of our society, and the decreases in educational quality and funding have presented the US with a tremendous problem, which may have implications not only for parents, but also for the future of the country. This section will examine educational Infrastructure current dilemma following the map illustrated in Figure 2.2 below.

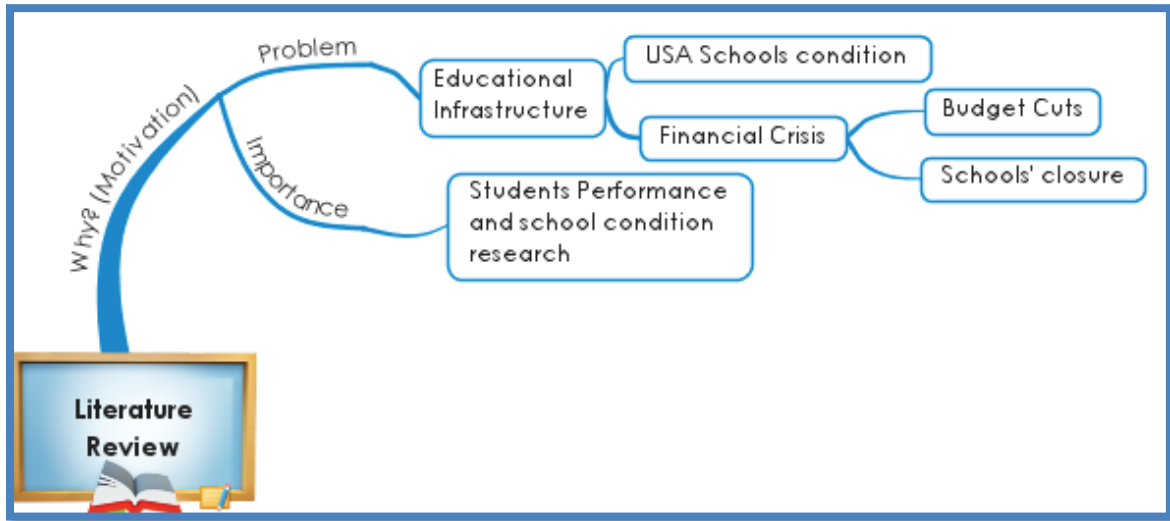

Figure 2.2 Literature Review Map for Educational Infrastructure Current Dilemma

2.2.1 U.S. Schools' Condition and Age

In 1995, a General Accounting Office (GAO) survey indicated that at least one-third of U.S. schools, serving around 14 million students, are in need for extensive repairs or major renovations. Moreover, approximately 60 percent of the nation's schools is in need of repair or replacement of at least one of their buildings' features (heating, ventilation, air conditioning, plumbing roofs, walls, etc.). Visits to school districts were made to conduct surveys about the conditions of their facilities and to determine the amount of funds needed for them to be considered suitable for student use. The surveys assessed the physical and environmental conditions of the facilities and the amount of money that has been spent in the last three years and the amount of money needed for repairs and renovations. The survey results showed that up to \$112 billion is needed for upgrading school facilities to good condition and to satisfy federal mandates.

In 2007, a U.S. Department of Education report presented updated information about school conditions in the U.S. The report addressed the sustainability of the physical conditions of buildings with time and the ability of schools to adapt with the change in the population rate. The data utilized were collected from elementary and secondary schools; and the report mainly depended on surveys conducted by the National Center for Education Statistics (NCES) to capture the satisfaction of public school principals with the condition of their school facilities. The survey examined nine aspects of the environmental conditions that should be satisfied in the school space: artificial lighting, indoor air quality, size or configuration of rooms, acoustics or noise control, physical condition, ventilation, heating, natural lighting, and air conditioning. The results showed that only 63 percent of the school principals surveyed were satisfied with the air conditioning in their schools, and around half of those surveyed think that at least one or more of the above nine factors can hinder their job performance.

According to the ASCE 2013 Report Card, the condition of K-12 school facilities in the U.S. is poor (grade D) and generally below standard. The ASCE report highlighted the jump in the needed budget for major repairs and renovation between a 1999 U.S. Department of Education report and today's expert opinion. In 1999, the U.S. Department of Education stated that at least \$127 billion is needed to bring schools to good condition, while experts think it will require an investment of \$270 billion or more for the same improvement. The report showed that the declining condition of schools has resulted from a lack of funding, which caused an increase in the gap between the needed upgrades of school facilities with respect to the increase in student enrollment numbers. Another point highlighted in this report was the age of our schools; nearly half of the public schools in the U.S. were constructed between 1950 and 1969, which means the average age of these schools is 54 years.

In 2013, the Center for Green Schools of the U.S. Green Building Council (USGBC) presented a report on school conditions. The report highlighted that the deferred maintenance budget needed for repairs at school facilities is around \$271 billion – almost \$5,450 per student. According to a Mallory Shelter (2013) article, the USGBC report estimated that the cost for both school repairs and modernization requirements at \$542 billion distributed over a 10-year period.

2.2.2 Financial Crisis and Education Budget Cuts

Education budgets have been suffering from increasing major cuts as a result of the financial crisis. In June 2012, 1,060 school administrators from 49 states completed a survey conducted by the American Association of School Administrators to measure the impact of these budget cuts. The respondents think that budget cuts would transform into major reduction to staff (56.6%) and academic programs (58.1%), increased class sizes (54.9%), and reductions in professional development (69.4 %). (Ellerson and Domenech, 2012).

School closures are another outcome of the financial crisis. An article written by Zhao in (2011) discusses school closures in many states. Schools funds are lower than they were in 2008 in almost 30 states. Seventeen states have cut funding by more than 10%; and some states like Hawaii, California, South Carolina, and Arizona have had to decrease their spending on schools by almost 20%. As a result, the states have forced school districts to raise their own revenue and trim educational services by laying off 194,000 staff members during the school year 2010/2011). Some states have succeeded in compensating the financial cuts, such as Maryland, Massachusetts, and Iowa by focusing on sustaining or improving education funding. The following states were mentioned as having the largest financial cuts: (Zhao, 2011)

- Michigan: Detroit Public Schools District had a deficit of \$327million.
- Texas: Public education funding was cut by \$5 billion.
- Wisconsin: \$800 million was cut from state education funding.

According to a Center on Budget and Policy Priorities (CBPP, 2011) report written by Johnson et al, the impact of major budget cuts that have been applied by many states can be exemplified by the following:

- Arizona: 4,328 children were eliminated from preschool, plus a major reduction for kindergarten funding.
- California: Assigned K-12 aid only to local school districts and eliminated many programs and activities
- Colorado: Reduced funds for public schools to \$400 per student.

- Georgia: Cut funding by \$403 million and reduced costs by exempting the local schools from putting class size into consideration.
- Hawaii: Shortened the school year by 17 days.
- Illinois: Reduced funding by \$311 million through major cuts in transportation funds, and termination of a grant program that was proposed to enhance study skills and reading.
- Maryland: Reduced professional development programs for teachers and enacted major cuts in health clinics and summer centers funding.
- New Jersey: Reduced funding for afterschool activities, which affected the level of achievement of the students, and laid off staff workers.
- North Carolina: Budget cuts resulted in leaving 20 low income schools without a social worker or nurse.
- Virginia: \$700 million in financial cuts reduced the possible capacity of class sizes and the number of support staff.
- Washington: Grants for education and other programs were suspended along with a reduction in class size.

In 2012, another report by the CBPP (Olaf et al, 2012) demonstrated the increase in educational budget cuts facing different states after the financial crisis. The report showed that a huge reduction in education budgets was made between 2008 and 2013. Alabama, California, and Idaho reduced more than \$1,000 per student during that period. Alaska, Alabama, and Washington reduced funding by more than \$200 per student during the financial year 2012/2013 alone.

In March 2013, the New York Times published an article about the closures of 54 public schools in Chicago (8%) in addition to another 100 schools that were closed during the last 12 years. The closures would save about \$560 million during the coming 10 years through reductions in annual operating costs.

As shown with the above examples, budget cuts are affecting school facilities in many different ways. For example, teacher layoffs and school closings will force nearby schools to accommodate their students and to exceed their designed capacity. As a result, overcrowded classrooms will accelerate the building deterioration process and will increase stress for students and teachers. Also, limited school funds will affect maintenance budgets, which will force school districts to focus only on critical repairs, thereby delaying the less critical issues for later years. Over time, these unresolved issues can get worse and become more expensive to repair.

2.3. School Facility Conditions and Student Performance

2.3.1 Overview

According to Professor Glen I. Earthman, “there is sufficient research to state without equivocation that the building in which students spend a good deal of their time learning does in fact influence how well they learn.” (Earthman,2004)

A survey study by Schneider in 2002 indicated that the quality of school facilities affects student behavior; in schools with poor conditions, actions like vandalism, absenteeism, violence, and racism were found to appear in a higher rate than schools with good facilities.

The impact of school facility conditions on student performance has been an important topic since 1970s for researchers from different backgrounds. Hundreds of research projects were reviewed by four syntheses studies conducted by Weinstein (1979), McGuffey (1982), Lemasters (1997), and Bailey (2009).

Bailey (2009) concluded that “The results of the previous three syntheses in 1979, 1982, and 1997, along with the results of the findings in this study, supported and indicated that building condition was directly related to student achievement, student behavior, and student attitude.”

2.3.2. Studies Investigating the Relation Between School Physical Condition And Student Performance

A majority of the studies that investigated the relationship between school building condition and student performance used the same methodology: 1) evaluating the condition of the school facility, 2) evaluating student achievement typically measured by standardized tests, and 3) investigating the relationship between facility condition and student performance (Earthman, 2004).

In 1993, Cash investigated the relationship between student achievement and behavior in rural, small high schools in Virginia and correlated it with their school conditions. Cash developed the Commonwealth Assessment of Physical Facilities (CAPE), which is a questionnaire-based instrument to evaluate the condition of school buildings. Student achievement was measured by grade 11 test scores. Student behavior was measured by the number of expulsions, suspensions, and violence incidents. The received data was modified with respect to the socioeconomic level, using the percentage of children approved for free or reduced-price lunches and examined through

covariance, regression, and correlations analyses. The study found that student test scores were higher in better condition school buildings. Replicated studies by Hines (1996) and Earthman, Cash, and Berkum (1996) reached similar conclusions.

In 2000, O'Neil presented a dissertation examining the relation between school conditions and student performance. O'Neil examined 73 middle schools in Texas in his efforts to understand how school building condition affects student achievement, behavior, and attendance and teacher turnover rates. School buildings were evaluated using a Total Learning Environment Assessment (TLEA) questionnaire. Student achievement was assessed using spring 1998 tests' scores from the Standards of Learning Assessments. TLEA was a combination of the CAPE assessment method developed by Cash (1993) and a Council of Educational Facility Planners International (CEFPI) instrument that was developed by Hawkins and Lilley in 1998. Collected data were analyzed using statistical procedures that included Pearson's product-moment correlations. O'Neil concluded that student achievement is directly proportional to the level of the learning environment.

Another study was conducted in Kuwait in 2002 by Al-Enezi, who modified the CAPE assessment instrument to fit the high school system in Kuwait. Building evaluation data were collected from school principals; and final examination scores were used to measure of student achievement. Al-Enezi found that boys majoring in science were affected by the physical conditions of the building while girls were not.

In 2005, Syverson examined the relationship between student performance and their school building condition in Indiana. A 25-question CAPE-based assessment questionnaire was mailed to the principals of 50 high schools in Indiana. School buildings were divided into three groups (substandard, standard, and above standard) based on their condition score. Student achievement was measured by their scores on the Indiana Statewide Test for Educational Progress (ISTEP). Using the Spearman Correlation Coefficient, Syverson concluded that a significant relationship existed between school facility condition and student achievement.

O'Sullivan (2006) used 205 randomly selected high schools in Pennsylvania in his research. A modified CAPE instrument surveyed school principals or principal designees through an on-line process. Student academic achievement was measured using a three-year scale score average in

the Pennsylvania System of School Assessment (PSSA) exams. O'Sullivan found a positive relationship between high school building conditions and student academic achievement using a step-wise multiple regression analysis.

Another study was conducted by Crook in 2006 for Virginia high schools. This study addressed the link between the conditions of schools measured by CAPE questionnaire results and the percentage of passing students in the Standards of Learning examination. It tested the relations between student achievement and the wall color, noise, acoustics, lighting, classroom structure, school building age, windows, flooring, heat, and floor maintenance. The assessment criteria were chosen to be either substandard or standard. Socioeconomic levels were controlled using eligibility rate for reduced/free lunch program. The data were examined using statistics, comparisons, and correlations analysis. The findings of this research supported those of previous studies.

A dissertation by Thornton in 2006 focused on poverty and minorities in the Commonwealth of Virginia. Thornton used the CAPE data from Crook (2006). The research was based on the following two major questions:

- 1) Is there a major difference between the unprivileged students in buildings rated as substandard and those rated as standard?
- 2) Is there a difference between students living in standard housing and substandard housing?

Thornton concluded that students living in economically unprivileged areas were not affected that much by the poor conditions of their school buildings.

In 2008, Fuselier focused on Pennsylvania middle schools where the buildings were evaluated using Schools Physical Environment Variables Assessment (SPEVA). SPEVA is a combination of the CAPE assessment by Cash 1993, and work by McGuffey (1982) that measured lighting, thermal, and acoustics factors in a 21-question survey. The SPEVA questionnaire was answered by 104 principals at different middle schools. A significant difference was found in the mathematics section of the Pennsylvania System of School Assessment (PSSA) scores, which supports previous research in that area.

Smith (2008) was interested in identifying the relationship between South Carolina public high school building conditions measured by a modified CAPE assessment and student achievement as measured on the High School Assessment Program (HSAP). The results were analyzed through AMOS (an add-on module for SPSS software), providing a sophisticated analysis level. Smith found that heating, ventilation and air-conditioning systems affect student performance.

In 2011, McLean's dissertation investigated elementary schools building conditions and their influence on student performance in Virginia. McLean developed an elementary school version of the CAPE assessment and called it the Assessment of Building and Classroom Conditions in Elementary Schools (ABCCES). The study found significant difference between the student attendance rates and the percentage of free and reduced-price lunch program eligible students.

Table 2.1 summarizes the degree of relational significance for studies that investigated the relation between school building conditions and student performance from 1987 to 2008. The table data were driven from the Lemasters (1997) and Bailey (2009) synthesis studies. Table 2.2 summarizes the studies that examined the relations between school building conditions and student performance.

Table 2.1 Studies Indicating Significant and Non-Significant Relationships Between School Building Conditions and Student Performance from 1987 to 2008
(Derived from Lemasters (1997) and Bailey (2009))

Significance	Relationship Found	No Significance	No Relation
1999, Lanham	1983, Karst	1999, Cervantes	
2000, Lewis	1991, Edwards	2001, Guy	
2000, O'Neill	1993, Cash	2005, Picus et al	
2002, Al-Enezi	1994, Cheng		
	1994, Yielding		
	1995, Earthman et al		
	1996, Hines		
	2001, Stevenson		
	2003, Lair		
	2005, Leung/Fung		
	2005, Syverson		
	2006, Crook		
	2006, Edwards		
	2006, O'Sullivan		
	2007, Bullock		
	2007, Geier		
	2007, Osborne		
	2008, Fuselier		

Table 2.2 Summary of the Studies that Examined the Relations Between School Building Conditions and Student Performance.

Research	Sample Used
Berner,1993 Paper	52 Public Schools Washington Dc
Cash,1993 Dissertation	Grade 11 47 High Schools Small, Rural-Virginia
Cheng,1994 paper	678 Classes 6th/5th 190 Elementary Hong Kong
Yielding,1994 Dissertation	3 Elementary Northern Alabama
Earthman et al,1995 paper	All High Schools (N=199)-11th Grade North Dakota
Hines,1996 Dissertation	88 High Schools -11th Metropolitan Virginia
Lanham, 1999 Dissertation	Grades 3 To 5 197 of 299 Randomly Selected Elementary Schools Virginia
Cervantes, 1999 Dissertation	Grades 4, 7, And 11 in 19 Public Schools in Alabama
O'Neill, 2000 Dissertation	73 Middle Schools Texas Region Xiii Esc+I17
Guy,2001 Dissertation	119 High School West Virginia
Stevenson, 2001 Report for Education Oversight Committee	Grades 3-5, 626 Public Schools Principals In South Carolina
Al-Enezi, 2002 Dissertation	56 High Schools Grade 12th Kuwait
Lair, 2003 Dissertation	29 Schools - 24,000 Students High-Performing, High-Poverty School District Ysleta Independent School District, Texas

Table 2.2 Continued

Research	Sample Used
Leung et al, 2005 paper	750 Primary Students Hong Kong
Picus et al, 2005 paper	60,000 Students (4th,8th,11th) Every School Building in Wyoming
Syverson, 2005 Dissertation	50 High Schools Indiana
Edwards, 2006 Dissertation	14 Middle School and 25 High School Urban, Columbus, Ohio
O'Sullivan, 2006 Dissertation	205 High Schools Commonwealth of Pennsylvania
Crook, 2006 Dissertation	142 High Schools 729 Eleventh Grade in Virginia
Monk, 2006 Dissertation	6 Middle Schools Humble ISD, Texas
Bullock, 2007 Dissertation	111 Of 300 Middle Schools Commonwealth of Virginia
Geier, 2007 Dissertation	Grades 3-5 Random 70 of 90 Elementary (30 Rural, 30 Urban, And 30 Suburban) Michigan
Mcgowen, 2007 Dissertation	High Schools with Enrollments Between 1,000 And 2000 And Economically Disadvantaged Enrollments Less Than 40%. Grades 9-12, Texas
Osborne, 2007 Dissertation	121 Fifth Grade Teachers From 40 Elementary Schools- 3 Relatively Wealthy Suburban Philadelphia Counties in Pennsylvania.
Valkiria Durán-NaruckI, 2008 paper	95 Elementary Schools in New York City
Vandiver, 2011 Dissertation	Grades 9-12 High Schools in Northeast Texas
McLean, 2011 Dissertation	Elementary Schools That Had 3rd, 4th And 5th Grade Students Commonwealth of Virginia.
Horswill, 2011 Dissertation	K-9 th , 2,000 facility audits Alberta, Canada

2.3.3 Studies Investigating the Relation Between School Building Systems and Student Performance

Studies which tried to explore the relation between school facilities condition and student performance tried also to investigate the different variables affecting student achievement, such as thermal comfort, air quality and ventilation, acoustics, and lighting conditions of the building.

2.3.3.1 Thermal Comfort and Indoor Air Quality

In 2004, Earthman published a report prioritizing 31 school facilities criteria using the available body of research in addition to his own studies and experience. The prioritization was based on the extent to which a component is affecting student performance. He recommended that the highest priority be given to the components directly related to student safety and health; then to the components directly related to student achievement; and, lastly, the components that were linked by research to student achievement. Clean water, fire safety, satisfactory lavatories, security systems, and emergency communication systems are the most important safety-related elements of a school facility. The first priority after the safety-related components is air quality and thermal comfort. Fifteen studies reviewed by Earthman identified a strong correlation between air conditioning and student achievement. Earthman added that student performance in non-air-conditioned classrooms was 3 to 12 percent lower than in air-conditioned classrooms. Moreover, extremely high temperatures could cause harmful physiological effects and decrease physical work ability. Polluted air in schools also can cause many diseases, such as asthma, which can affect both teachers and students.

The U.S. General Accounting Office (1995) found that about 15,000 schools suffer from poor indoor air quality. Poor air quality can affect children's health, causing symptoms such as headaches, fatigue, shortness of breath, coughing, sneezing, eye and nose irritation, and dizziness, which can inder their learning abilities. (Wargo, 2003)

Myhrvold et al (1996) conducted a study on indoor air quality and student performance. The result showed that poor ventilation increased the carbon dioxide levels in the classroom, which lowered the student scores on a concentration test given to them as a part of the experiment.

2.3.3.2 Lighting

In Earthman's opinion (2004), classroom lighting is the second priority component. Research showed a correlation between lighting and student performance where schools with adequate lighting quality helped their students to achieve better results in the exams.

2.3.3.3 Acoustical System

The acoustical system in classrooms is the third element of significance. Researchers have studied the relation between noise levels and student achievement. Students believed that high noise levels affected their ability to hear, concentrate, and understand their lessons, which affected their performance badly. Studies showed that excessive noise can increase teacher and student stress levels and blood pressure, which can hinder their performance. (Earthman, 2004)

2.3.3.4 Overcrowding

Overcrowding in school buildings is the last priority component that *directly* affects student performance. Overcrowded schools negatively influence both teachers and students. They prevent teachers from using sophisticated techniques in communicating with the students and reduce the interaction among students. They also affect the extracurricular activities in which students may practice.

2.3.3.5 School Age

The age of school buildings is another factor in examining the relationship between school building condition and student performance. Earthman indicated that 14 studies investigated the relationship between the school building age and the performance of students. All these studies reported that students in older schools performed less than those in new ones. Moreover, researchers found that student scores were 5 to 7 percent higher in modern schools than older ones. The reasons behind these findings can be that older buildings lack elements that are directly related to student performance. Thermal environmental control, appropriate lighting, and acoustical control are examples of such elements. Another study by Lyons (2001) added that the inflexibility in old schools prevents the use of some new interactive teaching techniques as well the enormous amount of funding that would be needed to renovate them.

Table 2.3 summarizes the degree of relational significance of studies that investigated the relation between the condition of different school building components and student performance for the period 1987 to 2008. The table data were derived from the Lemasters (1997) and Bailey (2009) synthesis studies.

2.4 Educational Facilities Asset Management

The term Asset Management was defined by the American Public Works Association Asset Management Task Force as “a methodology needed by those who are responsible for efficiently allocating generally insufficient funds g]f valid and competing needs” (Danylo et al, 1998). Figure 2.3 below illustrates the map for this part of the literature review.

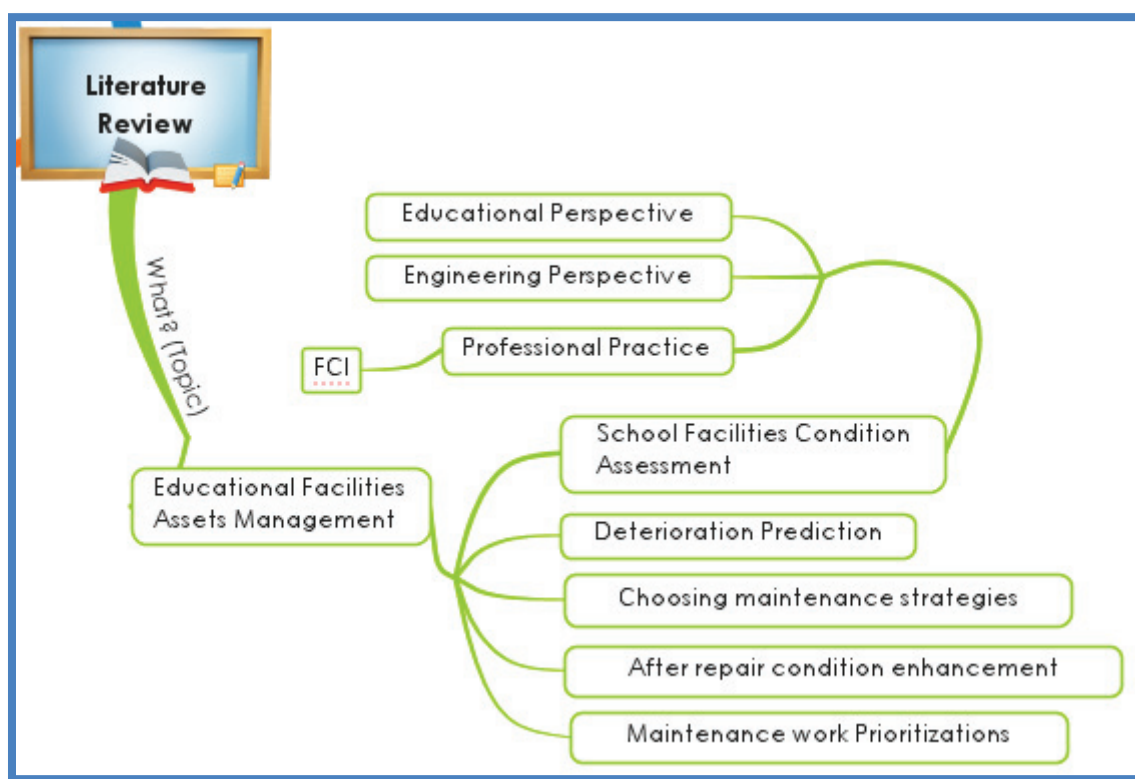

Figure 2.3 Literature Review Map for Educational Facilities Assets Management

Table 2.3 Studies Indicating Significant and Non-Significant Relationships Between School Building Components and Student Performance from 1987 to 2008
(driven from Lemasters (1997) and Bailey (2009)).

	Significance *	Relationship Found	No Significance	No Relation
Lighting	1987, London 1990, Harting 1999, Heschong 1999, Samuels	1990, Cohen 1993, Cash 1995, Earthman et al 1995, Grangaard 1995, Nicklas 1996, Hines 1995, Hathaway 2001, Dorgan 2003, Heschong 2003, Wei 2006, Battles	1980, Chan 1982, Krimsky 1984, Sydoriak 1990, Jue 1990, Knight 2008, Fuselier	1983, Ingraham
Thermal comfort and Air quality	1980, Chan 2000, Smedje et al 2005, Wargoeki et al	1980, Scagliotta 1984, Kaufman 1993, Cash 1995, Earthman et al 1996, Hines 2005, Perez et al	1990, Knight 1983, Murrain	
Noise	1982, Hyatt 1984, Ahrentzen 2001, Haines et al	1980, Cohen 1980, Zentall 1981, Pizzo 1984, Kaufman 1999, Rosenberg 1999, Lanham 2001, Moses 2004, Vilatarsana 2005, Wicks	1990, Knight 2001, Stapleton 2008, Fuselier	1993, Cash 1995, Earthman et al 1996, Hines
Age	1980, Garrett 1982, Chan 1988, Bowers et al 2000, O'Neill 2003, Kilpatrick	1987, Pritchard 1991, Edwards 1993, Cash 1996, Hines 2001, Guy 2003, Lair 2007, Bullock	2002, Hickman	1995, Earthman et al
Density	1984, Ahrentzen 1990, Jue	1989, Burgess 1994, Cheng 1995, Earthman et al 1995, Rivera-Batiz 1999, Cervantes 2000, Gentry 2000, Swift 2004, Maniloff 2006, Edwards	1998, Williamson	1993, Cash 1996, Hines 1995, Peatross

* At least at $p < .01$ or $p < .05$ level of Sig.

According to Elhakeem (2005) and Ahluwalia (2008), asset management encompasses the following main tasks:

1. Facilities condition assessment,
2. Future condition and deterioration prediction,
3. Choosing maintenance strategies,
4. After repair condition enhancement, and
5. Prioritization of maintenance work with respect to the available budget.

Elhakeem (2005) presented a framework for educational facilities asset management using life cycle cost analysis. The framework includes:

1. Distress-based simple visual condition evaluation technique that is less subjective,
2. School building components deterioration curves using Markov chain method,
3. Building components repair selection optimization model, and
4. Network-level prioritization and fund allocation optimization model.

Elhakeem created a user-friendly prototype for the proposed framework and tested it using data from the Board of North America's Schools. The prototype "proved to be practical and capable of optimizing repair funds for up to 1,200 components." (Elhakeem, 2005)

Ahluwalia (2008) developed a comprehensive framework for educational facilities condition appraisal. She created a hand-held system prototype and tested it on the Toronto District School Board (TDSB). The framework was innovative in three areas:

1. Prioritizing the repair tasks of a building's components by utilizing the available maintenance records and using the data for condition prediction and Inspection planning.
2. Extensive survey and field data collection were used to create a visual guiding system for uniform condition assessment of the components of buildings. This system was developed using a graphic database for components' different deficiencies to reduce the subjectivity of the evaluators.
3. Developing a location-based inspection process using a standardized hierarchy for buildings.

Ahluwalia (2008) focused on replacement-based maintenance strategies and condition ratings.

2.4.1 School Facility Condition Assessment

Ahluwalia (2008) stated that condition assessment is the most important task because its outcomes will be the base for the other asset management tasks. Kaiser (2009) in the “Association of Leadership in Educational Facilities Body of Knowledge” report defines facilities condition assessment as “the process of developing a comprehensive picture of the physical conditions and functional performance of buildings and infrastructure, analyzing the results of data collection and observations, and reporting and presenting findings.” The core objective of facilities condition assessment is “to measure the condition and functionality factors that make both the building and its infrastructure of adequate condition and appropriate for intended functions”. (Kaiser, 2009)

In general, condition assessment approaches can be classified as either monetary-derived or engineering-derived, as shown in Figure 2.4.

Engineering-Derived Condition assessment includes the building condition index (BCI) that was created by the U.S. Army Engineering Research and Development Center to evaluate the condition of building assets. The BCI is determined from the engineering-derived assessment which can be done in two ways, direct rating or distress rating. Direct rating involves visual assessment of the building components at the section level and not the sub-component level. The evaluator rates each component according to a condition index scale (*good* in green color, *fair* in amber color, and *poor* in red color). Direct rating is faster but less accurate. On the other hand, distress rating involves recording the subcomponent distresses along with their severity level and affected density amount to calculate the component-section condition index (CSCI). Then, the CSCIs are consolidated to compute the component condition index (BCCI), the system condition index (SCI), and the building condition index (BCI). (Uzarski and Grussing, 2008)

Monetary-derived condition assessment was developed in the 1960s by the U.S. Navy Bureau of Yards and Docks to enhance maintenance management practices. There are three approaches for monetary-derived condition assessment: 1) deficiency-based, 2) rating-based, and 3) inventory-based. The deficiency-based approach involves physical inspection by engineers and technicians to identify the deficiencies and estimate their current repair cost. The rating-based approach is a simpler and less expensive method than the previous. It involves rating the facility components using questionnaires, or visual inspections on a color (red, yellow, and green) or number (1 to 5)

scale. This rating can be done by building managers by following specified steps to evaluate the building condition. Lastly, the inventory-based approach computes a theoretical facility condition index (FCI) based on the building attributes databases. (Clayton, 2012).

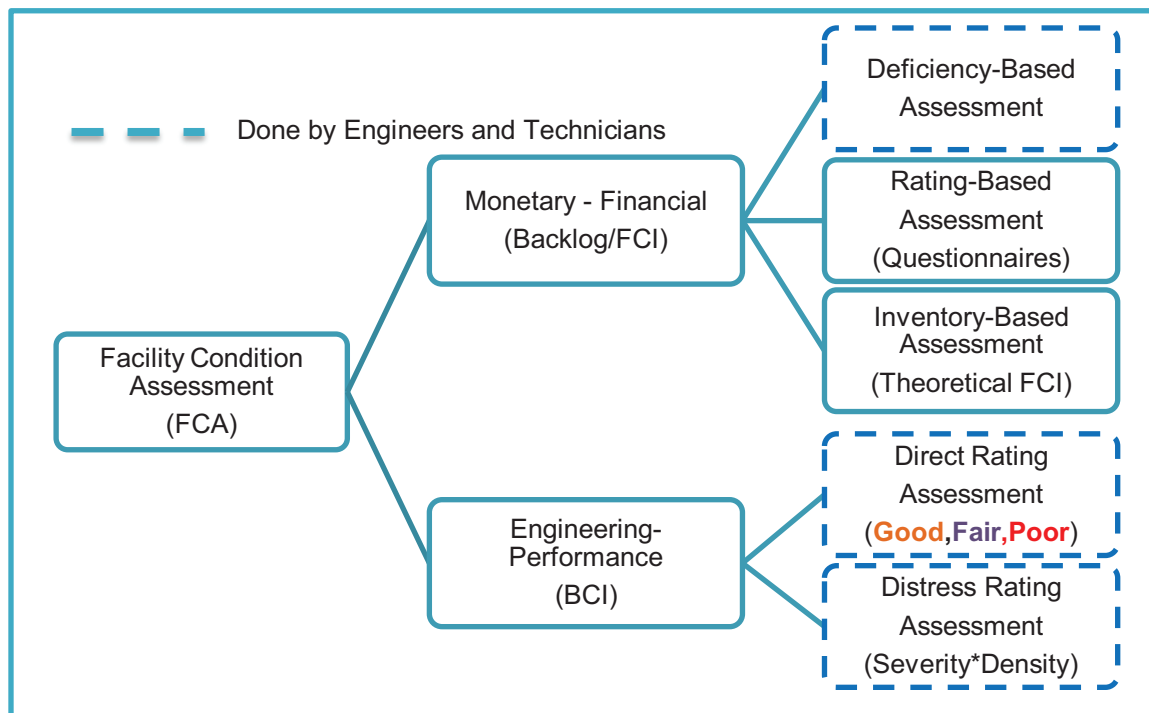

Figure 2.4 Condition Assessment Approaches

Based on the literature, the condition of educational facilities is measured from two different perspectives, educational or engineering, based on who conducts the assessment. The following section will discuss both types in more depth.

2.4.1.1 Educational perspective

Several assessment methods have been used to evaluate the condition of school facilities. Questionnaires are the most common method used by researchers with an educational background to assess the condition of school buildings through the opinions of school principals, teachers, and students. The main concerns with questionnaire-based methods are the subjectivity and accuracy of the responses.

The majority of the past studies utilized three main ingredients to explore the relationship between school building condition and student performance. The first ingredient is student achievement information, which can be obtained from standardized tests scores. The second ingredient is the socioeconomic status of the students, as measured by the percentage of students eligible for the National School Lunch Program, which is based on the student's household income. The third ingredient is the condition of the school building. To obtain this information, researchers used several types of assessment methods. Some researchers developed an assessment instrument such as the following: 1) The Model for the Evaluation of Educational Buildings (MEEB) developed by McGuffey (Professor of Educational Administration) in 1974; 2) The Guide for School Facility Appraisal Instrument developed by Hawkins and Lilley from the Council for Educational Facilities Planners International (CEFPI) in 1992; 3) The questionnaire developed by Cash (Professor of Educational Leadership) in 1993; and 4) The School Environment Suitability Assessment (SESA) created by Dr. Jeffrey Lackney (Educational Planner and Architect).

A few studies evaluated the stakeholders' perceptions of the impact of school facilities on student and teacher performance. In a study conducted by Stevenson (2001), a questionnaire was utilized to examine public schools principals' opinions as a part of a study on the relationship of school facilities components to school outcomes in South Carolina. A dissertation research presented by Yielding (1994) used a mixed methods in-depth survey to investigate users' perceptions of the impact of school facilities on the learning environment in three northern Alabama elementary schools. Yielding obtained his data using written questionnaires, interviews, and observations.

2.4.1.1.1 Commonwealth Assessment of Physical Environment (CAPE)

A popular example of questionnaire-based condition assessment is the Commonwealth Assessment of Physical Environment (CAPE) created by Cash in 1993. CAPE evaluates the school building based on the ideal condition that a school building should be to improve the student learning environment.

CAPE is composed of 27 questions, divided into structural items, which look at the building structure (16 questions) and cosmetic items, which look at the building cosmetic aspects (10 questions), as shown in Table 2.4. The last question asks the evaluator –normally the school's

principal – to rate the school as a whole as follows: below standard, standard, or above standard (Cash, 2003).

The majority of the questions have three possible condition answers from which to select. The condition answers are rated 0, 1, or 2. Based on the sum of all the answers, the buildings s divided into four quartiles. The upper quartile is above standard group, the lower quartile is the substandard group, and the two middle quartiles are the standard condition group (Cash, 2003).

Based on the subjectivity level, CAPE questions can be divided into three parts:

1. Objective questions: 1) seeking actual information about the school building such as school age and area; and 2) seeking information about a school building’s characteristics such as floor types, lighting types, wall color, etc. The latter type can be less objective in the case of mixed types. In that case, the evaluator chooses the best answer based on his judgment; for example, for Question 20, “what type of lighting is available in the instructional areas?” (Cash, 2013), the evaluator must choose from three available answers (incandescent, fluorescent-hot, or fluorescent-cold). The evaluator will use his judgment if the school has mixed types of lightings.
2. Less objective questions rely on the evaluator’s judgment to select from three given answers.
3. Subjective questions ask the evaluator’s opinion regarding the school building condition as a whole.

Based on the reviewed literature, CAPE was the most commonly used assessment tool by past researchers from an educational background. It was modified or mixed with other evaluations tools as shown in Tables 2.5 and 2.6.

Modifications to the CAPE tool include changing the question wording to a clearer format, adding or eliminating questions, or changing the answer options format.

Horswill (2011) consolidated CAPE’s limitations as listed by the studies that used them. One common limitation of any questionnaire-based tool is the self-reported nature of the evaluation, where staff members were assessing the condition of their own school, which may affect the

integrity of the study and inject bias. Another limitation is the difficulty of identifying all the factors influencing student performance. A third limitation mentioned by Fuselier (2008) was that school principals who choose to participate in the assessment usually are suffering from their school building condition, which will affect the study results.

Table 2.4 Structural and Cosmetic Items on the Commonwealth Assessment of Physical Environment (CAPE) as Created by Cash (1993)

Structural items	Cosmetic items
1. Building Age	1. Interior Wall Paint
2. Windows	2. Interior Paint Cycle
3. Flooring	3. Exterior Wall Paint
4. Heating	4. Exterior Paint Cycle
5. Air Conditioning	5. Floors Swept
6. Roof Leaks	6. Floors Mapped
7. Adjacent Facilities	7. Graffiti
8. Locker Condition	8. Graffiti Removal
9. Ceiling Covering	9. Classroom Furniture
10. Science Lab Equipment	10. Grounds
11. Science Lab Age	
12. Lighting	
13. Wall Color	
14. Exterior Noise	
15. Student Density	
16. Site Acreage	

Table 2.5 Studies that used CAPE-Based Evaluation Tools to Determine Building Conditions

Research	Evaluation Tool	Evaluator
Cash,1993	CAPE	Principals/designee.
Earthman et al, 1995	Modified CAPE = North Dakota instrument	Principals
Hines,1996	Modified CAPE	Principals
Lanham,1999	Modified CAPE (North Dakota version 1995) Added four questions about technology	Principals
Brannon, (2000)	Modified CAPE (Lanham version)	Principals
Al-Enezi,2002	Modified CAPE	Principals
Lair ,2003	Modified CAPE (North Dakota version 1995)	Principals
Syverson,2005	Modified CAPE (Hines version 1996)	Principals/designee
O'Sullivan,2006	Modified CAPE	Principals
Crook,2006	Modified CAPE	Principals
Bullock,2007	Modified CAPE	Principals
Thornton,2006	Modified CAPE	Principals
McLean,2011	Modified CAPE for elementary schools = ABCCES (Assessment of Building and Classroom Conditions in Elementary Schools)	Principals

Table 2.6 Studies that Used CAPE Hybrid Evaluation Tools to Determine Building Conditions

Research	Evaluation Tool	Evaluator
O'Neill,2000	Created (Total Learning Environment Assessment - TLEA) =Hybrid CAPE + CEFPI tool by (Hawkins & Lilley, 1992) (82 questions, 40 CEFPI, 10 CAPE)	Principals
Monk,2006	Used O'Neill's TLEA tool Hybrid CAPE + CEFPI by (Hawkins & Lilley, 1992)	teachers and administrators
Mcgowen,2007	Used O'Neill's TLEA tool Hybrid CAPE + CEFPI by (Hawkins & Lilley, 1992)	Principals/designee
Geier,2007	Modified CAPE with USGAO study Likert scale (United States General Accounting Office)	Principals
Fuselier, 2008	Created (School's Physical Environment Variables Assessment -SPEVA) SPEVA =Hybrid (CAPE + McGuffey's (1982) Fifteen physical environment variables)	Principals

2.4.1.1.2 The Guide for School Facility Appraisal Instrument (CEFPI) Instrument

The Guide for School Facility Appraisal Instrument was created by Hawkins and Lilley (1992) for the Council for Educational Facilities Planners International (CEFPI). It provides a comprehensive assessment system for the quality and adequacy of the educational facilities (Hawkins and Lilley, 1992). The tool measures the school facilities using the six major categories shown in Table 2.7. Each category contains a number of sub-categories with different maximum points. The evaluator rates each of the sub-categories with respect to the maximum allowable score, and the scores are totaled.

Cervantes (1999) used the CEFPI instrument to evaluate the condition of public school facilities in Alabama. The schools were evaluated by 15 doctoral students from the Department of Educational Leadership at The University of Alabama. The evaluators were trained under the guidance of Dr. Harold Bishop during 1998-1999.

Table 2.7 Main Categories of the CEFPI Guide for School Facility Appraisal, 1998 Edition

CEFPI Instrument Main Categories	Maximum Score	# of Sub-categories
The School Site	100	10
Structural and Mechanical Features	200	18
Plant Maintainability	100	9
School Building Safety and Security	200	20
Educational Adequacy	200	23
Environment for Education	200	17
Total	1000	97

2.4.1.1.3 Total Learning Environment Assessment (TLEA)

The Total Learning Environment Assessment (TLEA) was developed by O'Neill (2000) for a study on Texas public middle schools. TLEA consists of 82 items, 40 of which are based on the CEFPI Guide for School Facility Appraisal developed by Hawkins and Lilley (1998); 10 items

were based on the Commonwealth Assessment of Physical Environment (CAPE) developed by Cash (1993); and the remaining items were derived from the literature. For more details, please refer to Table 2 from O’Neil’s dissertation (2000). TLEA was also used by Monk (2006) and McGowan (2007).

2.4.1.1.4 School Environment Suitability Assessment (SESA)

Dr. Jeffrey Lackney developed another method of assessment called School Environment Suitability Assessment (SESA). SESA was used by Osborne (2007). Approximately 121 fifth grade teachers from 40 elementary schools in Pennsylvania were asked to evaluate their school buildings from their perspective. The survey contained 63 questions, divided into twelve categories, as shown in Table 2.8 (Osborne, 2007)

Table 2.8 Categories of School Environment Suitability Assessment (SESA)

Categories	Scale
1. Thermal comfort – 5 Questions 2. Acoustical quality – 6 Questions	1. Never 2. Very Seldom 3. Neutral 4. Often 5. Very Often 6. Always
3. Lighting – 4 Questions 4. Aesthetics and Appearance - 5 Questions 5. Safety and Security – 8 Questions	1. Very Poor 2. Poor 3. Fair 4. Neutral 5. Good 6. Very Good 7. Excellent
6. Crowding and Spaciousness – 5 Questions 7. Functional Flexibility – 9 Questions 8. Functional Proximity – 5 Questions 9. Sociality and Collegiality – 5 Questions 10. Privacy – 4 Questions 11. Personalization and Ownership – 4 Questions 12. Way-finding and Orientation – 3 Questions	1. Strongly Disagree 2. Disagree 3. Somewhat Agree 4. Neutral 5. Somewhat Agree 6. Agree 7. Strongly Agree

2.4.1.2 Engineering Perspective

Very few studies on school condition from an engineering evaluation perspective have been conducted compared to the huge body of research on school condition as evaluated by educators. On the other hand, school facilities condition assessment is extensively conducted in practice for maintenance planning purposes.

2.4.1.2.1 Total Building Condition Evaluation (TOTSBA)

Guy (2001) examined the relation between student achievement and school condition in 119 West Virginia high schools. For the school condition evaluation, Guy used the Total Building Condition Evaluation (TOTSBA) developed by the West Virginia School Building Authority (SBA).

As part of their ten-year comprehensive plan (2000-2010) for West Virginia educational facilities, each district had to complete three evaluation forms for each school. West Virginia SBA facility evaluation instruments must be completed by an architectural firm hired with West Virginia Legislature funds. (Guy, 2001)

As shown in table 2.9, the appraisal consists of three components:

1. Site Evaluation Component: evaluate the adequacy of the site sub-components shown in the table below.
2. Building Component Evaluation: provides information about the facility's structural condition.
3. Facilities Spaces Evaluation: examines the suitability of the facility for what was required by codes and guidelines.

Each of the sub-components in the three categories were evaluated according to a five- point Likert scale (1 = Inadequate; 2 = Below Average; 3 = Average; 4 = Above Average; and 5 = Excellent). Then, the scores of the available sub-components were averaged to a number between 1 and 5. Again, the total score on the facility evaluation (Total SBA Score) equals the average of the three components' scores.

Table 2.9 Total Building Condition Evaluation Component and Sub-component (Guy, 2001)

Component	Sub- Component
Site * (score 1 to 5)	1. Site Condition, 2. Drainage, 3. Parking, 4. Bus Loading Areas, 5. Access Roads, 6. Play Fields/Courts, 7. Site Utilities
Building* (score 1 to 5)	1. Building structure, 2. Floor structure, 3. Roof structure 4. Roof covering, 5. Wall finishes, 6. Ceiling finishes 7. Floor finishes, 8. Doors – Exterior, 9. Doors - Interior 10. Windows – Operating, 11. Windows – Fixed, 12. Boilers 13. Furnaces, 14. Air handling units, 15. Interior ventilation 16. Air handling heat systems, 17. Outdoor air ventilation 18. Heating/cooling units, 19. Electrical - Lights 20. Electrical - Fire Alarm System, 21. Electrical - Power/Receptacle, 22. Technology Infrastructure
Facilities Spaces* (score 1 to 5)	Two evaluations: 1- space size; 2- space condition. Spaces like: Administration, Student Services, Basic - Spaces for language arts, mathematics, social studies, science, Reading, Health Education, Staff/Faculty, Computer Lab, Toilets, Instructional Materials Center, Custodial, Kitchen, Dining, Home Economics, ..etc.

* Average score of available sub-components between 1 and 5

2.4.1.2.2. School Facility Evaluation Project (SFEP)/Facility Quality Index Survey (FQI)

Horswill presented his dissertation in 2011 exploring the relations between school conditions and student achievement. Horswill used school condition information from the School Facility Evaluation Project (SFEP). SFEP was created in July 1999 by the Government of Alberta to appraise 1,463 schools in Alberta. FQI survey was divided into seven main categories, as shown in Table 2.10. Each category was also divided into sub-categories containing several items. Sixty-one consultant teams of architectural, mechanical, and electrical engineers evaluated these items using a three-level scale: good, fair, or poor (Horswill, 2011 and Alberta Infrastructure, 2000).

Table 2.10 School Facility Evaluation Project (SFEP) Categories. (Horswill, 2011)

Categories	Sub-categories
1) Site Condition	<ul style="list-style-type: none"> • General (Playground, Safety and security camera ... etc.) • Access / Drop off / Road ways / Bus lanes • Condition (Parking spaces , Layoff and safety of parking... etc.)
2) Building Exterior	<ul style="list-style-type: none"> • Overall Structure • Roofing and Skylights • Exterior Walls / building Envelope • Exterior Doors and Windows
3) Building Interior	<ul style="list-style-type: none"> • Interior Structure • Materials and Finishes • Health and Safety Concerns
4) Mechanical Systems	<ul style="list-style-type: none"> • Mechanical Site Services • Fire Suppression Systems • Water Supply and Plumbing Systems • Heating Systems • Ventilation Systems • Cooling Systems • Building Control Systems
5) Electrical Systems	<ul style="list-style-type: none"> • Site Services • Life Safety Systems • Power Supply and Distribution • Lighting Systems • Network and Communication Systems • Elevators / Disabled Lifts
6) Portable Buildings	<ul style="list-style-type: none"> • General
7) Space Adequacy	<ul style="list-style-type: none"> • General • CTS Area • Other Non-Instructional Areas

2.4.1.3 Educational Facilities Condition Assessment – The Practice

2.4.1.3.1 Facility Condition Index (FCI)

The facility condition index (FCI) is the most common metric used in practice for evaluating school facilities condition. It also is called the asset condition index (ACI), financial condition index (FCI), or just the condition index (CI). The National Center for Education Statistics (2003) defines FCI as “a standard tool used by architects, engineers, and facility planners to compare the condition of school facilities and determine whether it is more economical to fully modernize an existing school or to replace it.”

FCI is a nationwide acceptable standard that has been used by: The National Association of College and University Business Officers (NACUBO) and the Association of Higher Education Facilities Officers (APPA). It is widely used in the fields of federal and state governments, higher education, and K-12 schools. It can be computed by dividing the total cost of deficiency repairs by the current building replacement value. Other facility condition metrics can be found in Table 2.11. FCI gives indications about a building or a portfolio’s overall financial health status. It ranges from 0 to 100 and can be interpreted using the guidelines in Table 2.12. The smaller the FCI value, the better the condition. All of the school condition data utilized in this proposed dissertation research was collected from official U.S. school districts’ master-plan reports available online. Many school districts around the country hire specialized consultants to assess the condition of their properties and evaluate their facilities’ related needs. This information will allow decision-makers to plan for future maintenance and capital renewal requirements when preparing budgets. In practice, school facility condition evaluation consists of visual inspection of each building by specialized teams to identify deficiencies, required corrective actions, and a prioritization level. To enhance the appraisal consistency and reduce subjectivity, evaluators use published definitions and checklists. Moreover, photos were taken to identify the deficiency significance. Then, the inspection data are entered into an assessment and capital planning database system. The majority of the reports available online were produced using two assessment database systems: 1) Energy and Condition Management Estimation Technology (eCOMET/COMET) and 2) Magellan Assessment and Project Planning System (MAPPS). A simple comparison between the two systems is shown in Table 2:13. (JACOBS et al, 2012 and Parsons Corporation and 3D/I, 2006).

Table 2.11 Facilities Condition Metrics

Metric	Formula or description
Facility Condition Index (Parsons Corporation,2012)	$FCI = \frac{\text{Cost of Deficiencies}}{\text{Current Replacement Value (CRV)}}$
Extended Facility Condition Index (Parsons Corporation,2012)	$EFCI = \frac{\text{Current Cost of Repairs} + \text{Projected Capital Renewal}}{\text{Current Replacement Value (CRV)}}$
Adaptive Index or Programmatic Index (functional adequacy) (APPA, et. al.,2003)	$AI \text{ or } PI = \frac{\text{Program Requirements (PR)}}{\text{Current Replacement Value (CRV)}}$
Facility Quality Index (APPA, et. al.,2003)	$FQI = FCI \text{ (Facility Condition Index)} + AI \text{ (Adaptive Index)}$

Table 2.12 FCI Scale Guidelines

APPANACUBO (Parsons, 2013a)	Magellan Consulting (Jacobs et al, 2010)	Parsons Corporation (Parsons, 2013a)
<ul style="list-style-type: none"> • 00.00 to 5%: Good • 05.01 to 10%: Fair • 10.01 to 60% Poor • > 60% Unsatisfactory 	<ul style="list-style-type: none"> • <5% Best • 6-10% Good • 11-20% Average • 21-30% Below Average • 31-50% Poor • 51-65% Very Poor • 66-100% Replacement 	<ul style="list-style-type: none"> • 00.00 to 15% Good • 15.01 to 30% Fair • 30.01 to 50% Poor • > 50% Unsatisfactory

Knowing the school area, current replacement value (CRV) can be calculated using RSMeans cost data. Parsons Corporation and 3D/I (2006) used a multiplier of 1.518 over the RSMeans unit prices to account for soft costs such as: bonds and insurance permits and fees, construction management overhead/profit, etc.). The FCI is then calculated by dividing the needed repair cost by the property current replacement value. In addition to the building visual appraisal, a life cycle capital renewal analysis is done based on a building's age and expected service life information. Capital renewal forecasting is an important part of long-term master planning (JACOBS et al, 2012 and Parsons Corporation and 3D/I, 2006).

The identified deficiencies are divided into five priority levels based on their significance.

1. Priority 1: Mission critical deficiencies that directly affect a school's ability to deliver education and fulfill its mission. Typically, this level includes safety, code compliance, or critical failures issues.
2. Priority 2: Potentially critical deficiencies that may affect the educational mission. It also includes critical systems exceeding their service life. This type of deficiencies has the potential to be critical and not fixed within one year; for example, poor roof condition that may fail causing serious disruptions for the educational operation. The increase in the required maintenance cost and other consequences if not fixed before failure must be added as well.
3. Priority 3: Mission necessary deficiencies which, if not repaired, can cause additional damage. It also includes necessary improvements needed to maximize efficiency, such as a school expansion to accommodate an increase in school enrollment; this type of deficiencies may not need instant attention and can be fixed within two to three years.
4. Priority 4: Recommended repairs or long-term requirements (three to five years). This type includes items that do not need immediate attention and can be attained within five years. It also includes systems exceeding their service lives with no signs of failure. Examples include pavement, finishes, and cabinets.
5. Priority 5: Enhancements: This level includes cosmetic items such as repainting, replacing carpeting, and signage enhancements.

Table 2.13 Educational Facilities Condition Assessment Database System

System	Magellan Assessment and Project Planning System (MAPPS)	Energy and Condition Management Estimation Technology (eCOMET/COMET)
Developer/ Used by	Magellan Consulting JACOBS	3DI/Parson's MGT of America
Building System Hierarchy/ Classification	12 industry-standard building systems. 1. Site 2. Roofing 3. Exterior 4. Structural 5. Interior 6. Mechanical 7. Plumbing 8. Electrical 9. Technology 10. Fire & life safety 11. Conveyances 12. Specialties	ASTM UNIFORMAT II A. Substructure B. Shell C. Interiors D. Services E. Equipment & Furnishings F. Special Construction & Demolition G. Sitework & Utilities
Examples : School District (SD)	<ul style="list-style-type: none"> • U-46 Elgin, Illinois. • Jeffco Public Schools. • St. Paul Public School District. • Baltimore City Public Schools. • Austin Independent SD. 	<ul style="list-style-type: none"> • DeKalb County School System. • Fergus Falls Public Schools. • Prince George's County • Caddo Parish Schools. • Orange Unified School District
Deficiency Prioritization	1. Mission Critical (Current) 2. Indirect Impact to Educational Mission (1 Year) 3. Short -Term (2-3 Years) 4. Long-Term Req. (3-5 Years) 5. Enhancements	1. Critical 2. Potentially Critical 3. Necessary 4. Recommended 5. Discretionary

2.5 Agent Based Modeling (ABM)

Agent-based modeling (ABM) is a powerful simulation method that has been used for studying complex systems in various areas (Bonabeau 2002). ABM is used widely for human behavior modeling and for capturing the complexity and interactions in the educational facilities management decision-making process. Therefore, ABM is used in developing the simulation tool for this research. This section introduces the ABM main concepts. Figure 2.5 below illustrates the map for this part of the literature review.

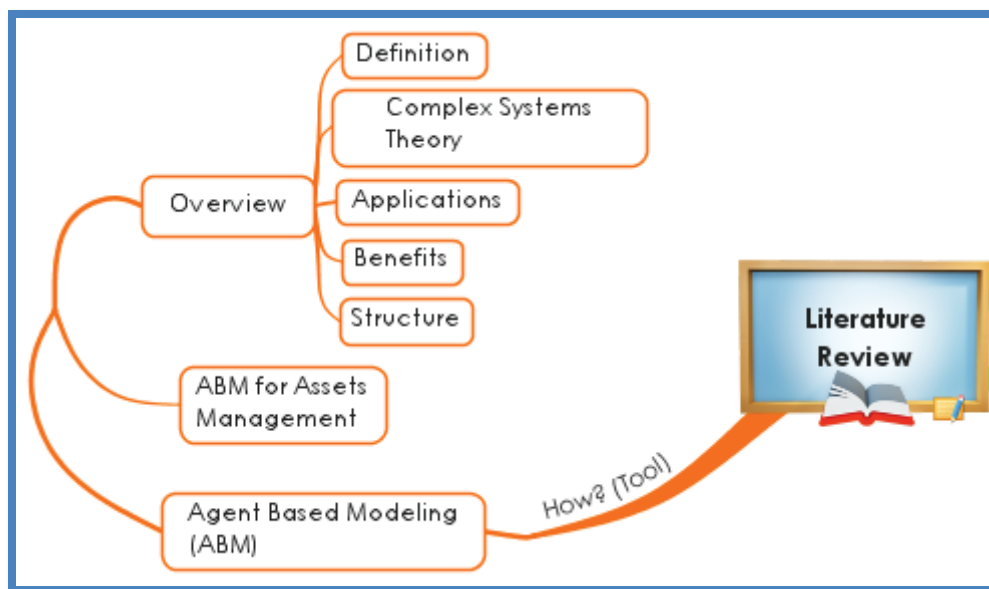

Figure 2.5 Literature Review Map for Agent Based Modeling (ABM)

2.5.1 An Overview of Agent Based Modeling

Torres (2013) defines agent-based modeling (ABM) as “a computational model for simulating the actions and interactions of a set of individuals (agents) in a network to assess their effects in global system behavior. It combines elements of game theory, complex systems, emergence, computational sociology, multi-agent systems, and evolutionary programming.”

ABM is a relatively new simulation method that is used for modeling complex and heterogeneous systems composed of interacting, self-directed, entities called agents. (Epstein et al, 1996; Macal et al, 2013) ABM advocate “Complex Systems Theory” where the diversity of agents’ characteristics and behaviors affect the overall system behavior (Heath et al 2009; Sanford Bernhardt 2004). ABM simulation is acting like “electronic laboratories” to support decision-making in exploring the effect of different strategies. (Macal and North, 2013)

Heath, Hill, and Ciarallo (2009) surveyed 279 ABM articles in different fields for the period from 1998 to 2008. The majority of the articles (88%) were from the fields of economics (29%), social science (24%), biology (14 %), military (13%), and public policy (8%). The researchers claim that ABM is the only modeling method that can explicitly capture the real-world complexity created from individual behaviors and interactions. According to Bonabeau (2002), ABM has three

benefits over other simulation methods: 1.ABM can capture the emergent behavior resulting from the agents' interactions, 2.ABM offers a natural explanation of the system, which makes it easy to model and understand. And 3.ABM is flexible and can be modified easily.

The typical ABM structure has three main components: 1) agents, 2) agents' environment, and 3) relations and connections between agents and with the environment (Heath et al, 2009; Macal et al, 2013). There is no specific definition for the term "agent," but Macal and North (2013) believe that agents have the following properties:

1. Modularity: Agents are self-contained objects with set of attributes and behaviors.
2. Autonomy: Agents are self-directed.
3. Sociality: Agents are social and interact with other agents.
4. Conditionality: Agents have states that vary over time.

Macal and North (2013) identified five common topologies of agents' social relations and interactions:

1. Soup: non-spatial model.
2. Grid/Lattice: Agents' neighbors are the immediate surrounding cells.
3. Euclidean Space: 2D or 3D spaces
4. Geographic information systems (GIS): Agents' locations are the geographic coordinates.
5. Network: Static predefined or dynamic links. Agents' locations are specified by network nodes and links.

2.5.2 Agent-Based Modeling (ABM) for Asset Management

ABM is a relatively new modeling technique for asset management. Minimal research has been done in that area, which had a focus on pavement network asset management, and will be illustrated in this section. There is a gap in the literature with respect to the use of ABM for building facilities asset management. Four studies were reviewed in the area of ABM for asset management (Sanford Bernhardt, 2004; Moore et al, 2007; Sanford Bernhardt and McNeil, 2008; Osman, 2012). A summary of the studies can be found in Table 2.14. As shown in figure 2.6, the general structure of these models is composed of four main agents: asset, user, maintenance personnel, and decision-

makers. Moore et al (2007) replaced maintenance personnel with two agents: work crew and engineer. The general idea behind pavement management ABM can be summarized as follows:

1. The asset condition changes and deteriorates with time and usage.
2. Asset usage is a function of the user's vehicle type and traffic size.
3. There is a two-way relation between the asset and the user. Users use the road and contribute to its deterioration. On the other hand, bad road conditions will make users complain to decision-makers. Moreover, bad road condition can also make users change their routes, which will create congestion and accelerate the deterioration of that road segment.
4. Decision-makers respond to user complaints and direct maintenance personnel to make repairs. Decision-makers set maintenance rules, strategies, and budgets based on complaint levels and their remaining time in their position.
5. Repair and renovation decisions are determined by maintenance personnel based on their experience, available budget, and the maintenance strategy set by decision makers.

Sanford-Bernhardt (2004) proposed a framework for the modeling of pavement network infrastructure management using a bottom up ABM. The researcher concluded that ABM has the potential to explore insights that will help improve an asset's performance.

Moore et al (2007) explored the use of ABM in pavement asset management modeling. They developed two prototypes to simulate decision-making for pavement asset management based on usage, deterioration, and maintenance interventions. The first prototype was created in MATLAB while the second was created in Repast. Both prototypes have five agents: pavement, user, work crew, engineer, and politician. Each agent type has attributes and actions/methods that define its behavior. The authors concluded that ABM has good potential for improving the management of infrastructure assets.

Sanford-Bernhardt and McNeil (2008) concluded that simple simulation methods cannot capture the effect of complex interactions and relations between the infrastructure system entities. They presented an ABM framework to improve pavement infrastructure decision-making. The authors concluded that ABM has the potential to help decision-makers in selecting interventions that will achieve better results over the asset life cycle.

Osman (2012) created a generic agent-based modeling framework for the management of urban infrastructure. Similar to previous studies, the author claims that complex system theory and a

bottom-up method are more suitable for infrastructure asset management modeling and simulation. The ABM framework consists of four main agents: assets, users, operators, and politicians. Each agent has a set of attributes and actions that define its behavior. Also, each agent has goals that may contradict with other agents. The author used Canadian road network data to test the model developed with AnyLogic 6. The case study showed the influence of the user social and psychological behavior on infrastructure consumption. Osman concluded that the study illustrated the power of ABM to simulate the complex relations between the agents. He also concluded that ABM can provide decision-makers with a tool to evaluate the impact of the different policies on the users. Table 2.14 presents a summary of previous studies showing the agents and their attributes.

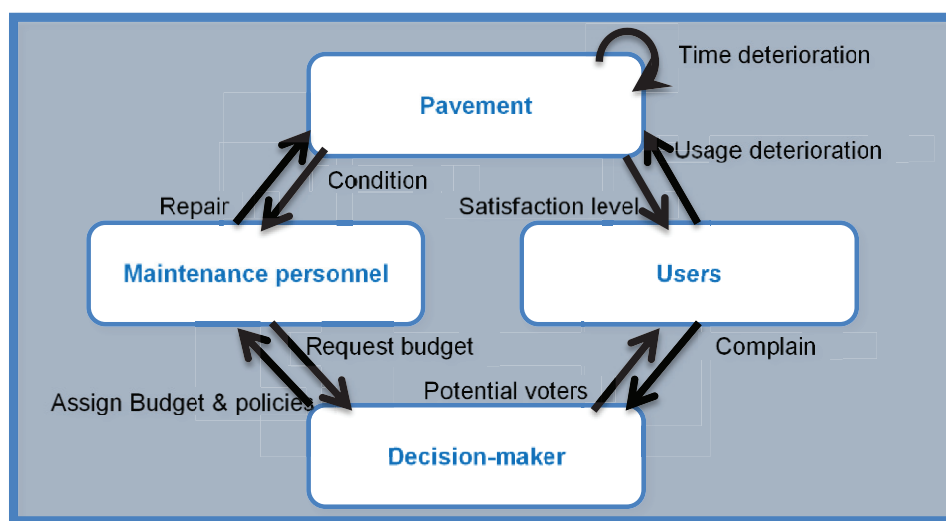

Figure 2.6 Agents and Interactions in Pavement Network Management Model

Table 2.14 Summary of ABM Studies for Asset Management

Study	Asset type (Tool)	Agents (Attributes)
Sanford Bernhardt, (2004)	Pavement Network (spreadsheet)	<ul style="list-style-type: none"> • Pavements (location, length, age, type, thickness, condition). • Drivers (vehicle type, route, trip purpose, income) • Maintenance personnel (experience, rules, budget) • Politicians/agency heads (support level, priorities, position remaining time)
Moore et al (2007)	Pavement Network (MATLAB, and Repast)	<ul style="list-style-type: none"> • Pavement (condition) • User (tolerance, type) • Work crew (work type, work quality) • Engineer (allotted funding, work assignment) • Politician (funding, assigned users)
Sanford Bernhardt and McNeil (2008)	Pavement Network (Theoretical framework)	<ul style="list-style-type: none"> • Pavement (material, thickness, location, length, age, network, condition) • User (route, vehicle weight, Income, user cost, attitude toward transportation funding) • Maintenance personnel (Experience, Available budget, maintenance rules) • Politicians/agency head (remaining time in position, support for transportation projects)
Osman (2012)	Urban Infrastructure Case-study: Road Network (AnyLogic 6)	<ul style="list-style-type: none"> • Infrastructure asset (inherent attr. environmental attr. deterioration rate, condition, risk, actual LOS, trigger LOS). • User (Type, Income, LOS expectations, tolerance level, satisfaction level) • Infrastructure Operators (intervention policy, risk tolerance, LOS policy, budget) • Politician/decision-maker (approval rating).

CHAPTER 3. AN OVERALL EDUCATIONAL FACILITIES DETERIORATION CURVE: A THREE-STAGE PREDICTION MODEL

3.1 Overview

Sanchez-Silva et al (2008) defined deterioration as “the loss of structural capacity with time as a result of the action of external agents or material weakening. It has many dimensions and depends, among others, on the type of structure, the constitutive material, the environmental conditions, and the operation characteristics.”

The aim of this chapter is to develop a methodology for creating an overall deterioration curve for educational facilities as a whole using the publicly available FCI data.

As discussed in the literature review of Chapter 2, the condition of school facilities has a direct and indirect impact on student performance. Numerous studies concluded that students perform better in a safe and pleasant school environment (Earthman et al, 1995). Therefore, this part of the study will focus on developing a condition prediction model for school facilities as a whole in order to enhance maintenance decisions.

The condition of school buildings is always subject to continuous change (deterioration) for many reasons, such as (Ahluwalia, 2008):

- 1- Aging wear and tear,
- 2- External and internal conditions (e.g., weather and misuse),
- 3- Overcrowding,
- 4- Advances in information technology that require upgrades in some building systems, and
- 5- Inadequate maintenance, which also has the potential to accelerate the deterioration process.

Deterioration modeling is a complex and challenging task, mainly because of the following reasons cited by Elhakeem (2005):

- 1- The deterioration process is affected by many unforeseen factors.
- 2- The lack of historical data.
- 3- The inconsistency and uncertainty in deterioration behavior.

3.2 Deterioration Modeling

Deterioration modeling approaches have been developed since the early 1970s to help decision-makers in predicting the conditions of facilities and optimizing the resource allocations. The models can be classified into three categories: deterministic, stochastic, and artificial intelligence, as shown in Figure 3.1 (Setunge et al, 2011).

3.2.1 Deterministic Models

The deterministic approach mainly defines space and time by one single quantity. It uses mathematical and statistical formulas to obtain the relationship between the factors affecting facility deterioration and facility condition. They ignore the random errors facing their predictions; also, they may assume that some factors like the environment and initial conditions are not affected by any outside factors. The techniques used in this approach are: 1) straight-line extrapolation and 2) regression models (stepwise regression, linear regression, nonlinear regression, and multiple regression). (Setunge et al, 2011 and Elhakeem, 2005).

3.2.2 Stochastic Models

In the stochastic approach, the randomness and uncertainty of the deterioration process are considered in the models. Stochastic models can be classified into two main groups: state-based models and time-based models (Mauch et al, 2001).

State-based models predict long-term asset performance using the probability of condition state change over a given period of time (Morcoux et al, 2006). Markov chain models are the most popular state-based models and it will be used in this research. Markov chain models have been applied to different infrastructure types such as: buried pipes systems (Abraham et al,1999; Micevski et al,2002; Baik et al, 2006; Ana et al, 2010; Riveros et al, 2014), bridges: (Cesare et al,1992; Madanat et al, 1995; DeStefano et al,1998; Morcoux et al,2002; Morcoux,2006; Setunge et al,2011; Bocchini et al, 2013; Li et al,2014; Wellalage et al,2014; Wellalage et al,2015; Li et al, 2016), pavement: (Li et al, 1996; Gao et al, 2013; Abaza,2016), and buildings: (Zhang, 2006; Edirisinghe et al,2015).

The second stochastic model type is the time-based models which employ the probability distributions of the time the asset takes to change its condition from one state to the next lower state. (Mishalani et al, 2002). The transition time probability distributions used in the time-based models includes: parametric, semi-parametric, and non-parametric distributions (Morcoux et al, 2006). The time-based deterioration models were used mainly for bridges (Mauch et al, 2001; Aboura,2009; Yang et al,2013). Mauch and Madanat (2001) discussed both types giving some examples from the literature.

3.2.3 Artificial Intelligence Models

The third approach is based on artificial intelligence (AI) techniques as was developed to model the long-term performance of elements. The main advantage of this approach is that it overcomes challenge of the lack of historical condition information. This approach uses computational techniques such artificial neural networks, genetic algorithm, and hybrid systems (Setunge, et al, 2011 and Elhakeem, 2006). Artificial neural networks (ANN) are the most common (AI) technique used for infrastructure deterioration modeling.

Huang and Moore (1997), La Torre et al. (1998), Owusu-Ababio (1998), Sherkharan (1998). Lou et al. (2001), and Yang et al. (2003) used Artificial neural networks technique for pavement condition prediction. Najafi and Kulandaivel (2005) presented a paper in pipeline condition prediction Using ANN Models.

Genetic algorithm was used by Shekharan (2000), and Hedfi & Stephanos (2001) for pavement deterioration modeling. Hybrid systems were applied by Abdelrahim and George (2000) for pavement condition perdition modeling. A summary of artificial intelligence applications for infrastructure deterioration and condition prediction modeling can be found in Flintsch & Chen (2004) and Sharma & Gupta (2016).

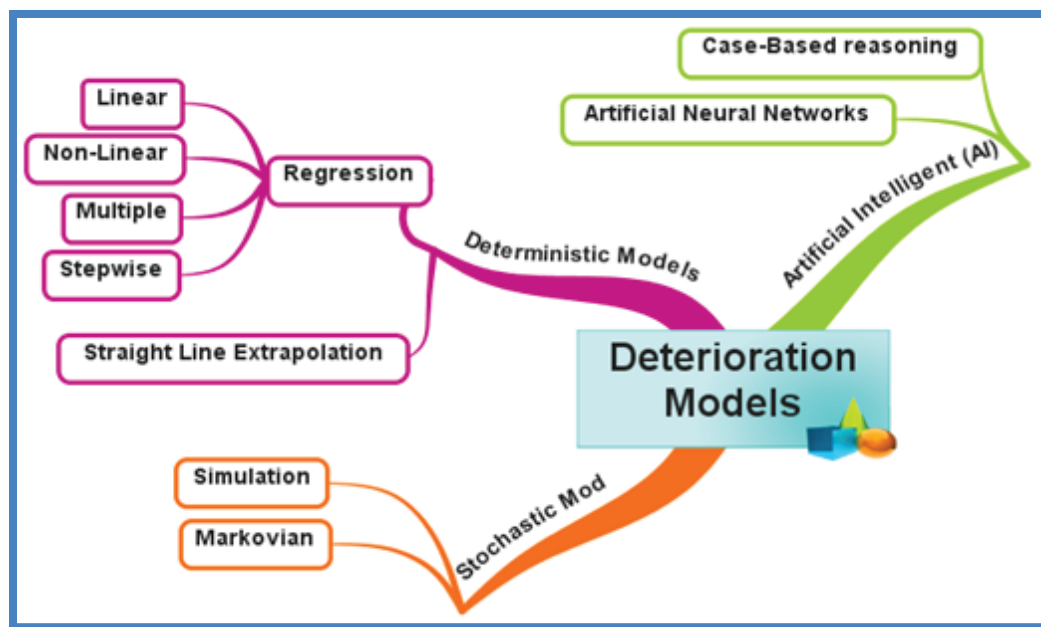

Figure 3.1 Deterioration Models

3.3 Markov Chain Condition Prediction Modeling

The Markov chain modeling approach is a widely used method for Infrastructure deterioration modeling. It is used to represent and show the change of the condition from one state to another. This change is called a step. It measures the probabilities of transitions into the different condition states over time. The transition probabilities are stored in a matrix called the transition probability Matrix (TPM), where the rows represent the present states and the columns show the future state (Setunge et al, 2011 and Elhakeem, 2005). An example for three condition states transition matrix and state chart are shown in Figure 3.2.

The Markov transition probability matrix (TPM) was used in a great deal of the past research in maintenance optimization of pavements, bridges, and sewer infrastructure. The Markov transition matrix can be calculated using the frequency approach described below. (Jiang et al, 1988, and Setunge et al, 2011).

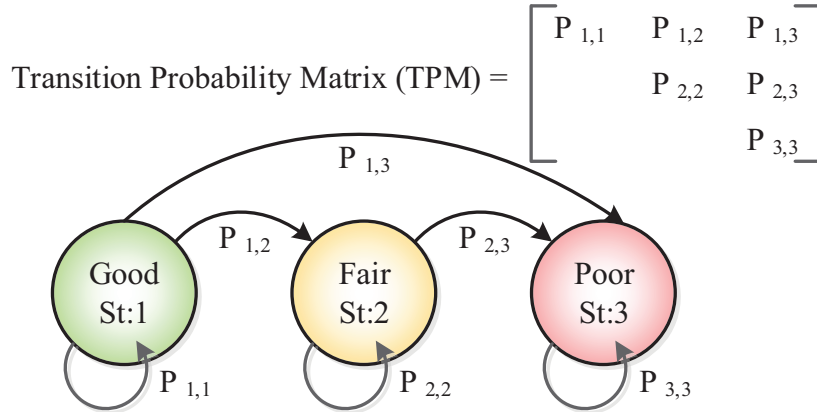

Figure 3.2 Markov State Chart and Transition Matrix for Three States Deterioration Conditions

The frequency approach is a percentage prediction method. It can be obtained easily and directly from the conditions data. The following equation is used to calculate the probability of transition between state i to state j : (Setunge et al, 2011).

$$P_{ij} = \frac{n_{ij}}{n_i} \quad (3.1)$$

Where:

- P_{ij} is the probability of transition from state i to state j during a certain time interval.
- n_{ij} is the number of the transition cases from state i to state j , and
- n_i is the number of elements in state i before transition.

The TPM is used to estimate the future condition. If the current condition vector (CP) is known, the future condition vector (FP) can be computed at any number of time transition periods (t) as follows: (Collins, 1972 and Elhakeem, 2005)

$$FP = CP \cdot TPM \quad (3.2)$$

For the purpose of developing a deterioration curve, the condition at time zero ($t = 0$) is assumed to be perfect and the initial probability vector can be written as follows:

$$P_0 = [1, 0, 0, 0, \dots, 0] \quad (\text{Collins, 1972 and Elhakeem, 2005}).$$

The next step is to compute the FP using Equation (3.2). The resulted vector will become the current vector CP for the next time transition period. The same procedure is continued until the last state condition (critical condition) is reached and no further transition is possible.

Once the FP is obtained, then the value of a single condition state can be calculated as follows:

$$\text{Condition (t)} = \text{FP (t)} \cdot \text{PS} \quad (3.3)$$

Where PS is the vector of possible states (e.g., in the example shown in Figure 3.2, PS = [Good, Fair, Poor] or [1,2,3])

The last step is to plot the transition time on the x-axis and condition (t) obtained from Equation 3.3 on the y-axis to create the deterioration/condition prediction curve.

3.4 Conceptual Methodology

The objective of this chapter is to explain the development a new methodology for creating an overall deterioration curve for school facilities that can also be applied to any multi-systems/components facilities. The proposed deterioration model will be developed through a three-stage approach, which is described below and shown in figure 3.3.

Stage 1: Identify the overall deterioration pattern of educational facilities, which can be achieved through the following procedure:

- Review the current deterioration modeling techniques and identify the most suitable one for the present research.
- Use case study data to develop an overall deterioration model for school facilities.
- Validate the developed model using another dataset for the same facilities.
- Use the developed model to identify the overall deterioration pattern of school facilities as seen in real world.

Stage 2: Determine the average useful service-life of educational facilities as a whole, which can be achieved through the following procedure:

- Examine the current methods used for Facility Condition Index (FCI) calculation in practice to identify building systems breakdown.

- Develop a method to unify the different systems breakdowns found in practice.
- Estimate the different school building systems percentages for using historical/statistical educational facilities condition needs (\$).
- Compute the average useful life for each building system based on sub-system weights and their nominal average useful life guidelines.
- Compute the weighted average service life of school facilities as a whole using the results from the previous two steps.

Stage 3: Determine the upper and lower deterioration rate boundaries the represent facility condition with and without doing the recommended maintenance. That can be achieved through the following procedure:

- Evaluating the annual condition of school facility as whole.
- Evaluating the life cycle renewals effect on the annual condition over time.
- Plotting the resulted values against time, to create deterioration curve for educational facility maintained and renewed according to building industry standards.
- Analyze the resulted curve and simplify by the means of linear regression. The slope of the resulted line will be the lower boundary on the deterioration rate.
- Determine the lower boundary of deterioration rate by investigating the amount of recommended maintenance according to building industry standards for educational facilities.
- Verify the results by compare it with first stage results.

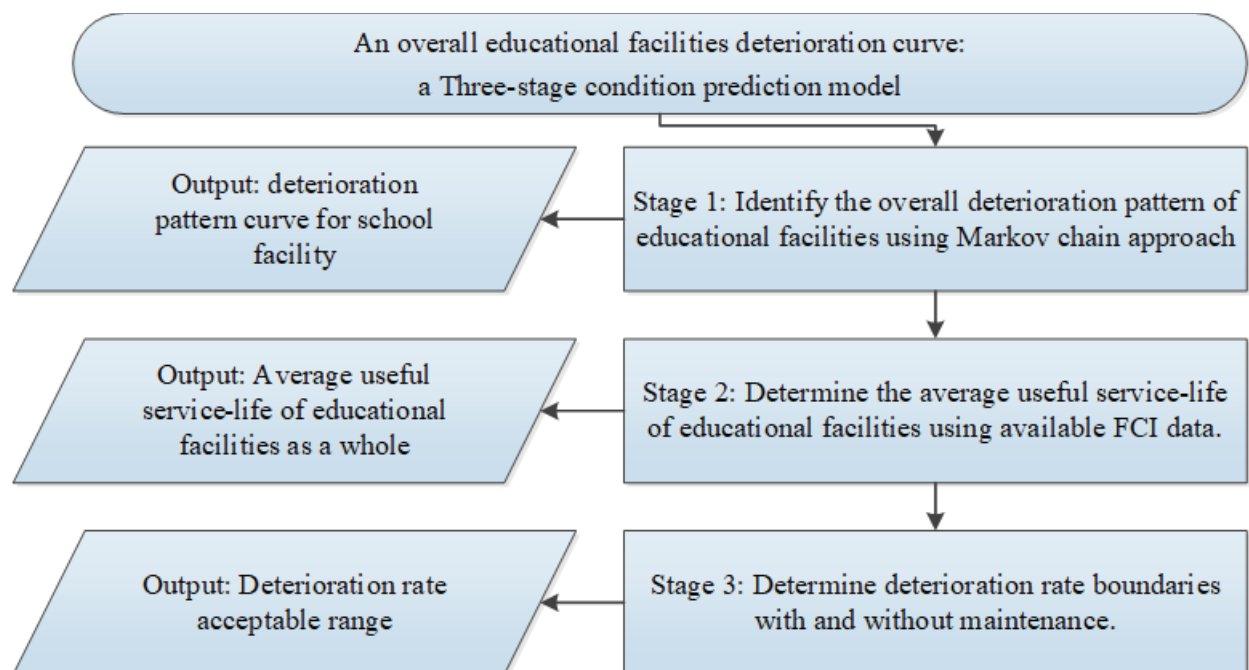

Figure 3.3 Condition Prediction Modeling Conceptual Methodology

3.5 Results and Discussion

3.5.1 Stage 1: Identify the Overall Deterioration Pattern of Educational Facilities

The purpose of this part is to recognize the overall deterioration pattern of educational facilities using publicly available condition assessment data (e.g., FCI). As mentioned at the beginning of Section 3.4, this task starts with reviewing the current deterioration modeling techniques to identify the most suitable one for the present research. Section 3.2 provides a brief introduction to the available deterioration and condition prediction techniques. Markov chain deterioration modeling method was chosen for the purpose of this task since it is widely used for Infrastructure deterioration modeling (Jiang et al, 1988; Setunge et al, 2011; Elhakeem, 2005). Section 3.3 provided a step-by-step procedure for the Markov chain modeling approach.

Figure 3.4 and the following section outlines the main tasks for developing the overall Markov chain deterioration model.

Task 1: Data Collection

The data for the purposes of this research were collected from the FCI data of Prince George's County Public Schools (PGCPS), which is a large school district administered by Prince George's County, Maryland and overseen by the Maryland State Department of Education. A summary of the PGCPS data is shown in Table 3.1

Table 3.1 Summary of Prince George's County Public Schools (PGCPS) Data

Facility Name	Ave. Age (2012)	count	Gross Area (Sq. Ft.)	Repair Cost	FCI %	Rating
Elementary Schools	48	110	6,080,919	\$866,136,697	52.08%	Fair
Middle Schools	45	24	2,991,868	\$407,830,837	50.77%	Fair
High Schools	46	22	4,979,077	\$532,033,061	40.77%	Fair
Academies	45	4	486,897	\$68,521,852	55.16%	Fair
Special Schools	44	9	425,430	\$76,755,951	62.12%	Fair
Other	58	17	1,052,237	\$175,373,348	63.74%	Fair
Total	48	186	16,016,428	\$2,126,651,745	49.52%	Fair

For the purpose of this task and since we have the FCI data for each school in Prince George's County Public school district for the years (2001, 2008, and 2012), The available data can be divided into two sets. Each dataset included a pair of FCI data for the same facility from different years as follows:

- 1- Dataset 1: Year 2001 and year 2008 FCI Data: 7 years span.
- 2- Dataset 2: Year 2008 and year 2012 FCI Data: 4 years span.

Task 2: Data Preparation

This step includes two activities: 1) removing strange and missing data and 2) removing the data for the facilities with a negative FCI change between the two years. Since higher FCI value means the worse the facility condition, Negative FCI Change reflect the improvement in condition which is out of our interest because we are interested in the deteriorated cases. Specially that transition probability matrix (TPM) we need to construct in the next step operate in one direction that is from

good condition to worse condition. Another reason for removing negative FCI change is to get more accurate results when comparing the two datasets.

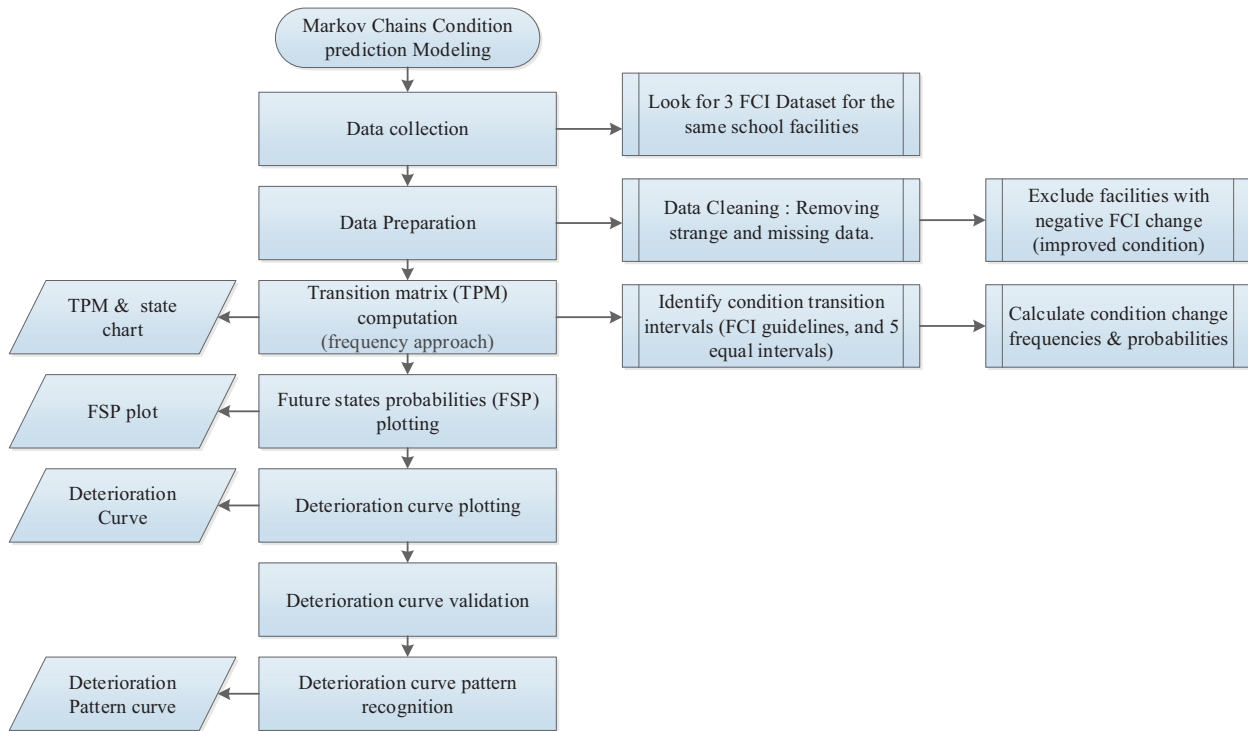

Figure 3.4 Markov Chain Condition Prediction Methodology

Task 3: Transition Matrix Computation

This process starts with Identifying transition intervals; and we choose two different intervals:

- 1) Case 1: Five equal intervals. (0%-20%, 20%-40%, 40%-60%, 60%-80%, 80%-100%).
- 2) Case 2: FCI guidelines used by Prince George's County Public Schools (PGCPS): 0%-40%, 40%-75%, 75%-100%.

Next, we calculated the change frequency (counts) from one interval to another in order to calculate the probability, using Equation 3.1, and created the transition matrix. Tables 3.2 to 3.5 show the transition matrix for the two datasets. Figures 3.5 and 3.6 illustrate the Markov chain state charts for the two datasets using both cases.

Table 3.2 Transition Matrix for Five Equal Intervals Case (Dataset 1: 2001 – 2008)

Mid-point	10	30	50	70	90	Sum
Range FCI	0-20	20-40	40-60	60-80	80-100	
Very Good, St:1	0.6	0.4	0.0	0.0	0.0	1
Good, St:2	0.0	0.05	0.28	0.67	0.0	1
Fair, St:3	0.0	0.0	0.3	0.7	0.0	1
Poor, St:4	0.0	0.0	0.0	0.9	0.1	1
Very Poor, St:5	0.0	0.0	0.0	0.0	1.0	1

Table 3.3 Transition Matrix for FCI Guidelines Three States Case (Dataset 1: 2001 – 2008)

FCI	Good	Fair	Poor	
Good (0-40%)	0.39	0.61	0	1
Fair (40-75%)	0	0.9	0.1	1
Poor (75-100%)	0	0	1	1

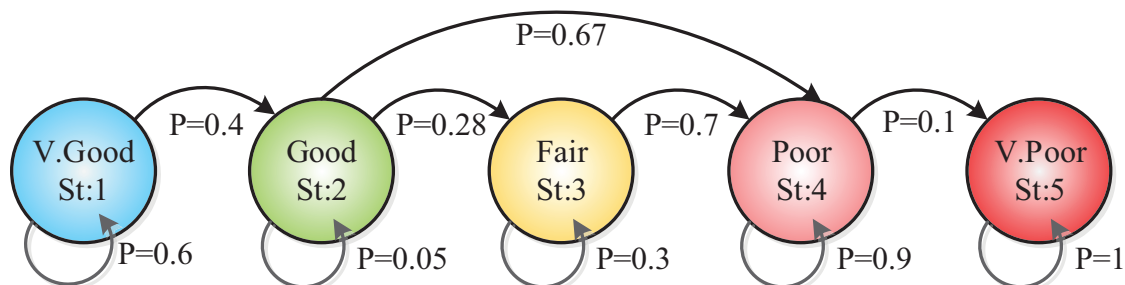

a) Five equal intervals.

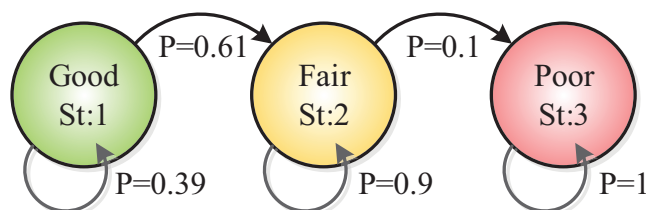

b) FCI guidelines.

Figure 3.5 Markov Chain State Chart (Dataset 1: 2001 – 2008)

Table 3.4 Transition Matrix for Five Equal Intervals Case (Dataset 2: 2008 – 2012)

Mid-point	10	30	50	70	90	Sum
Range FCI	0-20	20-40	40-60	60-80	80-100	
Very Good, St:1	0.4	0.6	0.0	0.0	0.0	1
Good, St:2	0.0	0.5	0.5	0.0	0.0	1
Fair, St:3	0.0	0.0	0.8	0.2	0.0	1
Poor, St:4	0.0	0.0	0.0	1.0	0.0	1
Very Poor, St:5	0.0	0.0	0.0	0.0	1.0	1

Table 3.5 Transition Matrix for FCI Guidelines Three States Case (Dataset 2: 2008 – 2012)

FCI	Good	Fair	Poor	
Good	0.65	0.35	0.00	1
Fair	0.00	0.98	0.02	1
Poor	0.00	0.00	1.00	1

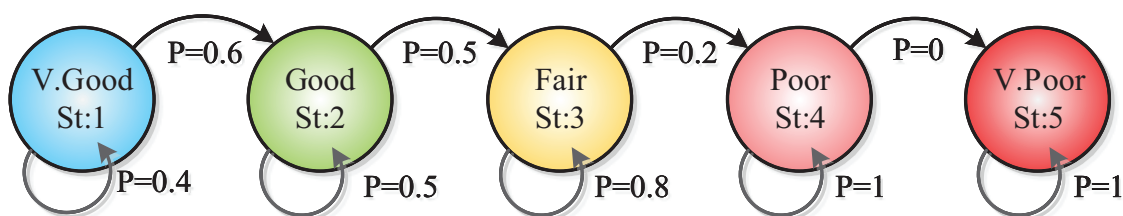

a) Five equal intervals.

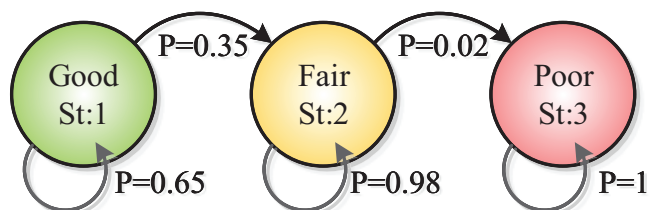

b) FCI guidelines.

Figure 3.6 Markov Chain State Chart (Dataset 2: 2008 – 2012)

Task 4: Future States Probabilities Plotting

The future states probabilities at the different time periods were calculated using Equation 3.2, where we assumed that the initial state vector (1, 0, 0, 0, 0) for case 1 or (1,0,0) for case 2. These initial state vectors mean that the probability of the facility being in condition state 1 (perfect condition) at time zero is 100%. The plots for time and the probabilities of the different states are shown in Figures 37 and 3.8.

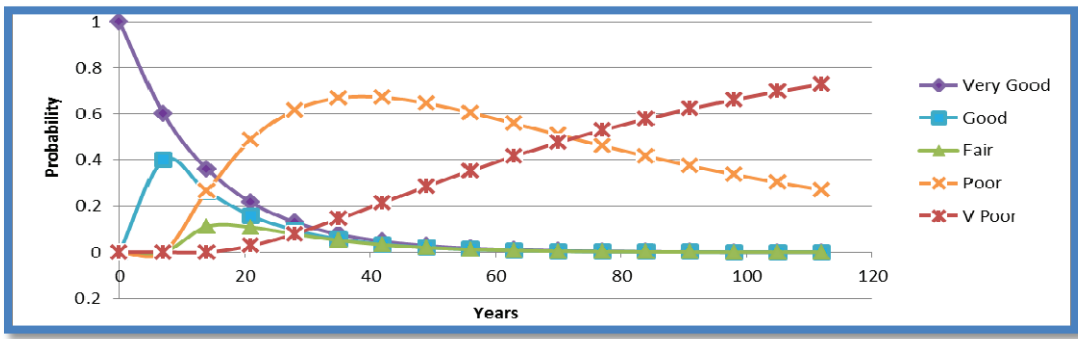

a) Five Equal Intervals.

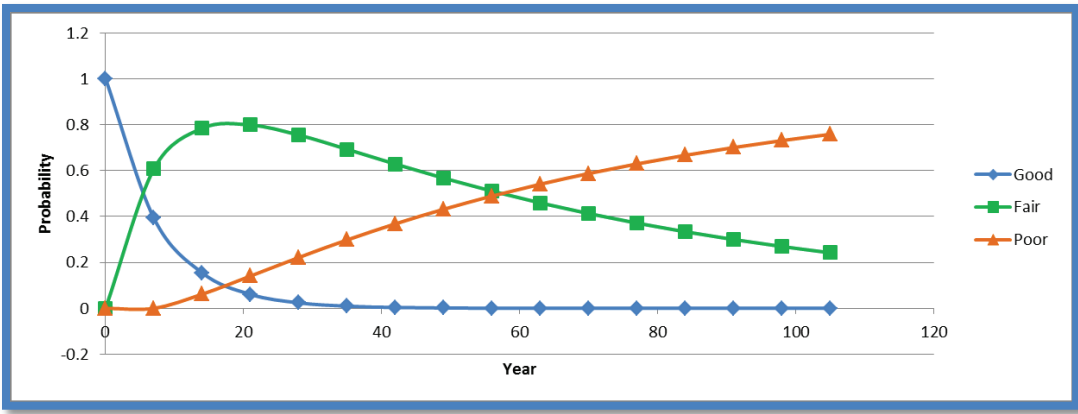

b) FCI Guidelines.

Figure 3.7 Relation Between Time and the Probabilities of Each State (Dataset 1: 2001 – 2008).

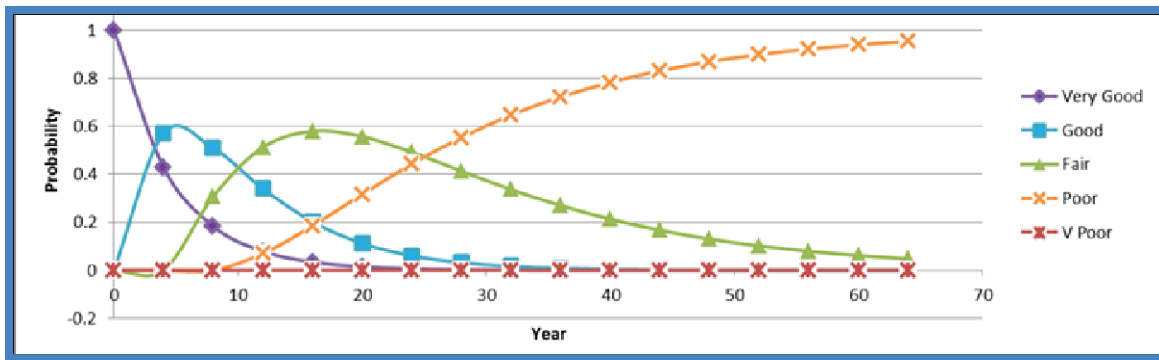

a) Five Equal Intervals.

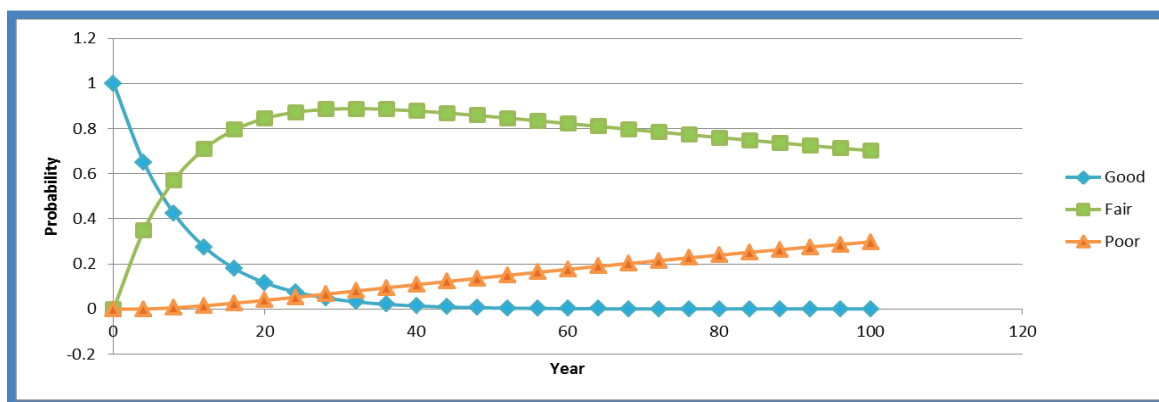

b) FCI Guidelines.

Figure 3.8 Relation Between Time and the Probabilities of Each State (Dataset 2: 2008 – 2012)

Task 5: Deterioration Curve Plotting

After computing the future states probabilities, the facility condition was calculated using Equation 3.3 and the midpoint of each time interval.

For example, in case 1, the midpoints are 10%, 30%, 50%, 70%, and 90%. Equation 3.3 can be rewritten as follows:

$$\text{Condition (t)} = 10 * P_t(\text{St1}) + 30 * P_t(\text{St2}) + 50 * P_t(\text{St3}) + 70 * P_t(\text{St4}) + 90 * P_t(\text{St5}) \tag{3.4}$$

Figures 3.9 a and b display Markov chain deterioration curves for the two datasets and the two cases in addition to a third order polynomial regression fitting for each curve.

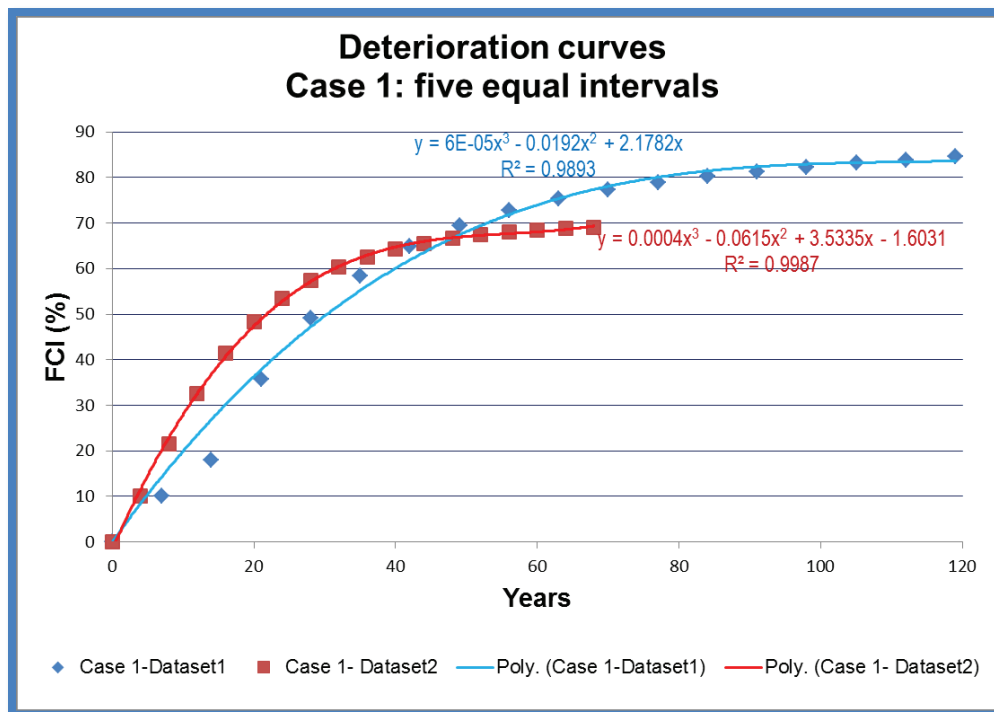

a) Case 1 Markov Chain Deterioration Curves for DS1 and DS2

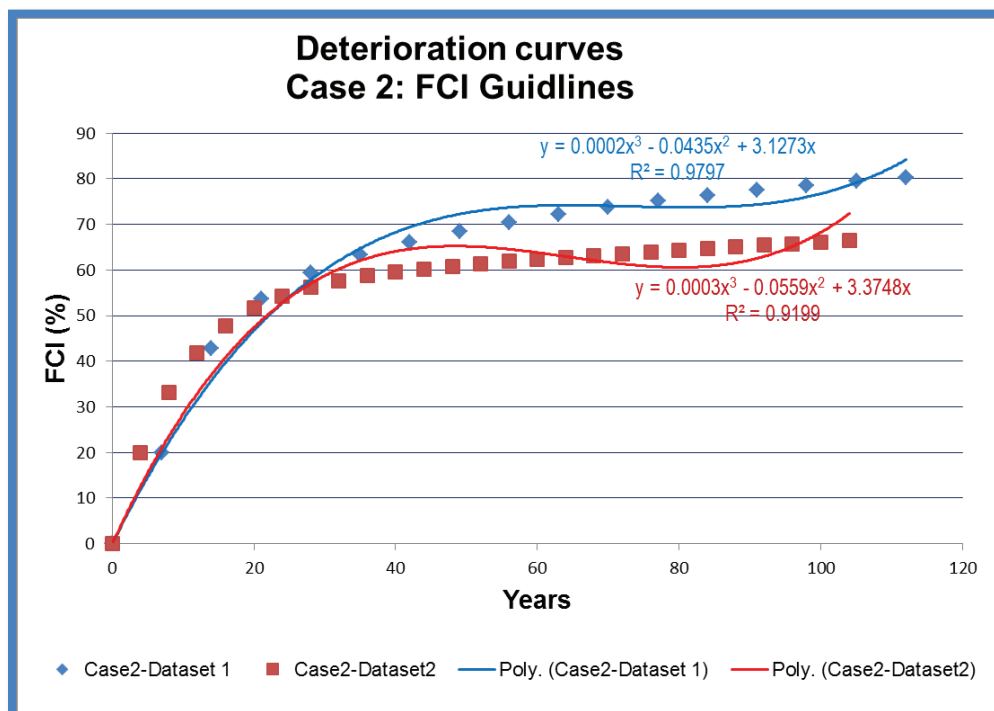

b) Case 2 Markov Chain Deterioration Curves for DS1 and DS2

Figure 3.9 Markov Chain Deterioration Curves

Task 6: Deterioration Curve Validation

As shown in Figure 3.10, the model can be validated by comparing the curves from the two datasets with each other. It is very clear that all the curves have the same behavior starting with a high deterioration rate followed by slower deterioration rate. Similar results were found by Setunge et al (2011) for concrete bridges, and Edirisinghe et al (2015) for building components deterioration modeling. The next stage will provide some explanation of the resulted behavior where will see four major building components have useful service expected life of 20 to 25 years.

Task 7: Deterioration Curve Pattern Recognition

Figure 3.10 shows an initial high deterioration rate (steep slope FCI range from 50-60%) for the first 20 to 25 years of the facility age. Later, the deterioration rate gradually decreases with time until it reaches the worse condition state (state 5 for case 1, and state 3 for case 2).

The resulted curves can be simplified into a two-part straight-line plot. The first part represents the high deterioration rate. The second part represents the low deterioration rate. Three points are needed to construct the simplified graph. The first point is the start point with (age=0, and FCI=0).

The second point is the point where the deterioration rate changed from high to low. The second point can be assumed to be a mid-point in the changing pattern area shown in Figure 3.10 (age= 22.5, FCI= 55). The third point is needed to plot the second straight line part of the plot. Based on Figure 3.10, the third point can be assumed (age=70, and FCI=70). Using these three points, a simplified deterioration pattern plot was developed for school facilities, which is shown in Figure 3.11.

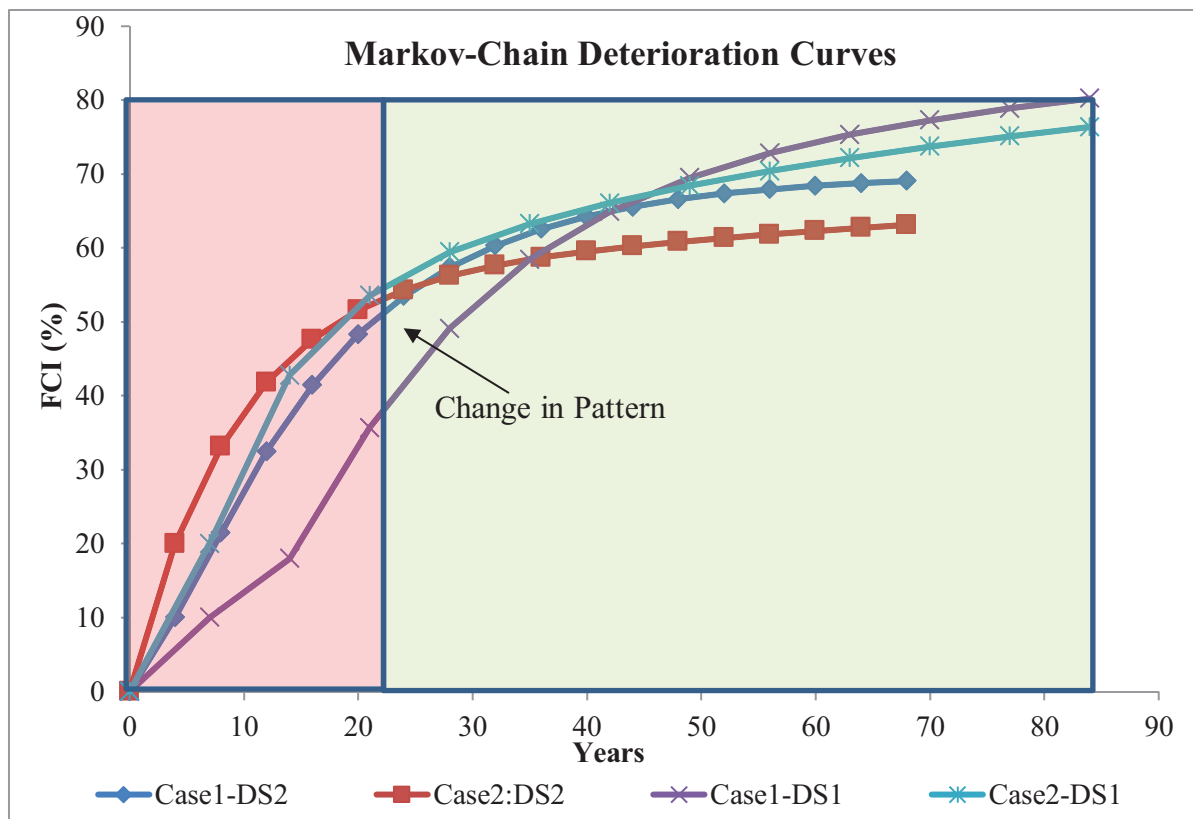

Figure 3.10 Markov Chain Deterioration Curves for the Two Datasets

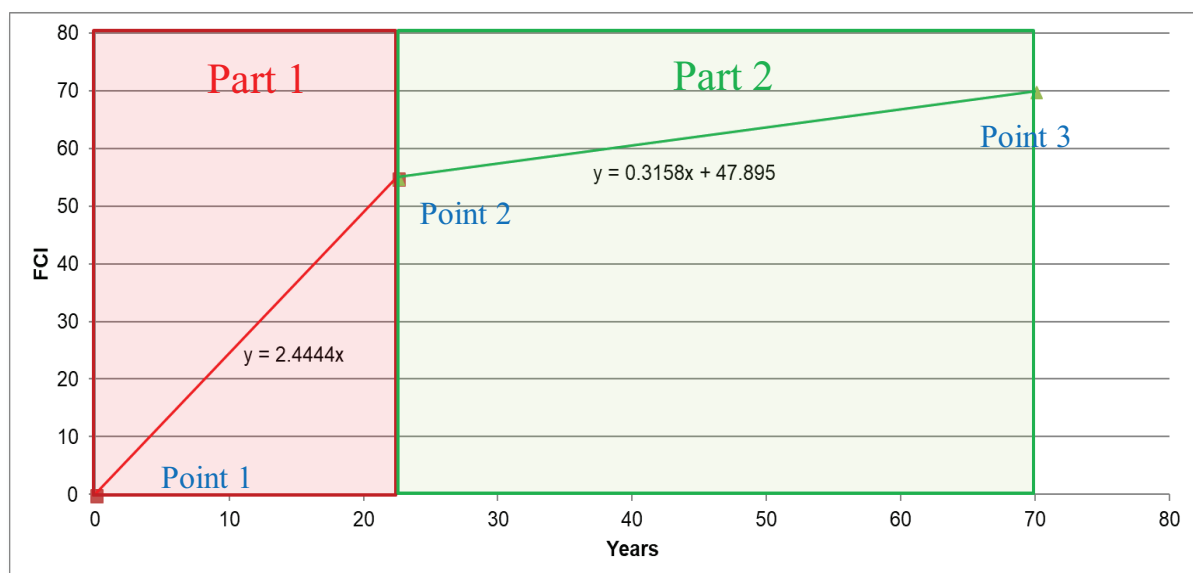

Figure 3.11 Simplified Overall School Facilities Deterioration Pattern Plot

3.5.2 Stage 2: Determine the Average Useful Service-Life of Educational Facilities

The purpose of this stage is to determine the average nominal life of a school facility as a whole.

The proposed methodology is composed of two main tasks:

- To identify how the different school building systems/components contribute to the overall maintenance needs cost.
- To estimate the nominal life of the different school building systems/components.

Task 1: Identifying School Building Systems/Components Percentages

This task can be accomplished through the following activities:

1. Survey the FCI computation approaches used in practice to identify the different building systems breakdown.
2. Develop a system to combine the different building systems breakdowns found in practice for computing FCI.
3. Evaluate historical/statistical FCI data to compute the percentages of the different school building systems.

In practice, the FCI is used widely for school facilities condition evaluation. Section 2.4.1.3. reviewed the main concepts associated with FCI. MAPPS and eCOMET/COMET are the two main assessment database systems used for calculating FCI. Each system follows a different building breakdown hierarchy.

Magellan Assessment and Project Planning System (MAPPS) was developed by Magellan Consulting, and it uses 12 industry-standard building systems as follows: site, roofing, exterior, structural, interior, mechanical, plumbing, electrical, technology, fire and life safety, conveyances, and specialties. A 13th category sometimes is added for other items not included in the 12 previous mentioned systems.

The COMET/eCOMET system was developed by 3DI/Parson's consultancy and it uses the ASTM UNIFORMAT II classification which is divided into the following major group elements: substructure, shell, interiors, services, equipment and furnishings, special construction and demolition, and sitework and utilities. Each major group elements (level I) is divided into group

elements (level II) which in turn is divided into individual elements (level III). Table 3.6 illustrates level I and level II of the ASTM Unifomat II classification. A detailed list can be found at ASTM international (2007).

Table 3.6 ASTM Unifomat II classification for building elements
(ASTM international, 2007)

Level I Major Group Elements	Level II Group Elements
A Substructure	A10 Foundations
	A20 Basement Construction
	B Shell
B Shell	B10 Superstructure
	B20 Exterior Enclosure
	B30 Roofing
C Interiors	C10 Interior Construction
	C20 Stairs
	C30 Interior Finishes
D Services	D10 Conveying
	D20 Plumbing
	D30 HVAC
	D40 Fire Protection
	D50 Electrical
E Equipment and Furnishings	E10 Equipment
	E20 Furnishings
F Special Construction and Demolition	F10 Special Construction
	F20 Selective Building Demolition
G Sitework and Utilities	G10 Site Preparation
	G20 Site Improvements
	G30 Site Mechanical Utilities
	G40 Site Electrical Utilities

As mentioned before, the purpose of this step is to identify how the different building systems contribute to the maintenance needs cost. Since both the MAPPS and eCOMET/COMET assessment systems follow different building systems breakdown, a conversion is needed to unify the building components structure. Table 3.7 (a to m) proposes a method to convert the UNIFORMAT II classification into the 12 industry-standard building systems used by MAPPS.

Table 3.7 UNIFORMAT II to MAPPS Conversion

a) Site System.

UNIFORMAT II Level I	UNIFORMAT II Level II	UNIFORMAT II Level III
G Sitework and Utilities	G10 Site Preparation	G1010 Site Clearing
G Sitework and Utilities	G10 Site Preparation	G1020 Site Demolition and Relocations
G Sitework and Utilities	G10 Site Preparation	G1030 Site Earthwork
G Sitework and Utilities	G10 Site Preparation	G1040 Hazardous Waste Removal
G Sitework and Utilities	G20 Site Improvements	G2010 Roadways
G Sitework and Utilities	G20 Site Improvements	G2020 Parking Lots
G Sitework and Utilities	G20 Site Improvements	G2030 Pedestrian Paving
G Sitework and Utilities	G20 Site Improvements	G2040 Site Development
G Sitework and Utilities	G20 Site Improvements	G2050 Landscaping
G Sitework and Utilities	G30 Site Mechanical Utilities	G3010 Water Supply
G Sitework and Utilities	G30 Site Mechanical Utilities	G3020 Sanitary Sewer
G Sitework and Utilities	G30 Site Mechanical Utilities	G3030 Storm Sewer
G Sitework and Utilities	G30 Site Mechanical Utilities	G3060 Fuel Distribution
G Sitework and Utilities	G30 Site Mechanical Utilities	G3090 Other Site Mechanical Utilities
G Sitework and Utilities	G40 Site Electrical Utilities	G4010 Electrical Distribution
G Sitework and Utilities	G40 Site Electrical Utilities	G4020 Site Lighting
G Sitework and Utilities	G40 Site Electrical Utilities	G4030 Site Communications & Security
G Sitework and Utilities	G40 Site Electrical Utilities	G4090 Other Site Electrical Utilities
G Sitework and Utilities	G90 Other Site Construction	G9010 Services and Pedestrian Tunnels
G Sitework and Utilities	G90 Other Site Construction	G9090 Other Site Systems & Equipment

b) Roofing System.

UNIFORMAT II Level I	UNIFORMAT II Level II	UNIFORMAT II Level III
B Shell	B30 Roofing	B3010 Roof Coverings
B Shell	B30 Roofing	B3020 Roof Openings

c) Exterior System.

UNIFORMAT II Level I	UNIFORMAT II Level II	UNIFORMAT II Level III
B Shell	B20 Exterior Enclosure	B2010 Exterior Walls
B Shell	B20 Exterior Enclosure	B2020 Exterior Windows
B Shell	B20 Exterior Enclosure	B2030 Exterior Doors

d) Structure System.

UNIFORMAT II Level I	UNIFORMAT II Level II	UNIFORMAT II Level III
A Substructure	A10 Foundations	A1010 Standard Foundations
A Substructure	A10 Foundations	A1020 Special Foundations
A Substructure	A10 Foundations	A1030 Slab on Grade
A Substructure	A20 Basement Construction	A2010 Basement Excavation
A Substructure	A20 Basement Construction	A2020 Basement Walls
B Shell	B10 Superstructure	B1010 Floor Construction
B Shell	B10 Superstructure	B1020 Roof Construction

e) Interior System.

UNIFORMAT II Level I	UNIFORMAT II Level II	UNIFORMAT II Level III
C Interiors	C10 Interior Construction	C1010 Partitions
C Interiors	C10 Interior Construction	C1020 Interior Doors
C Interiors	C10 Interior Construction	C1030 Fittings
C Interiors	C30 Interior Finishes	C3010 Wall Finishes
C Interiors	C30 Interior Finishes	C3020 Floor Finishes
C Interiors	C30 Interior Finishes	C3030 Ceiling Finishes

f) Plumbing System

UNIFORMAT II Level I	UNIFORMAT II Level II	UNIFORMAT II Level III
D Services	D20 Plumbing	D2010 Plumbing Fixtures
D Services	D20 Plumbing	D2020 Domestic Water Distribution
D Services	D20 Plumbing	D2030 Sanitary Waste
D Services	D20 Plumbing	D2040 Rain Water Drainage
D Services	D20 Plumbing	D2090 Other Plumbing Systems

g) HVAC System

UNIFORMAT II Level I	UNIFORMAT II Level II	UNIFORMAT II Level III
D Services	D30 HVAC	D3010 Energy Supply
D Services	D30 HVAC	D3030 Cooling Generating Systems
D Services	D30 HVAC	D3040 Distribution Systems
D Services	D30 HVAC	D3050 Terminal and Package Units
D Services	D30 HVAC	D3060 Controls and Instrumentation
D Services	D30 HVAC	D3070 System Testing & Balancing
D Services	D30 HVAC	D3090 Other HVAC Systems and Equipment
G Sitework and Utilities	G30 Site Mechanical Utilities	G3040 Heating Distribution
G Sitework and Utilities	G30 Site Mechanical Utilities	G3050 Cooling Distribution
D Services	D30 HVAC	D3020 Heat Generating Systems

h) Electrical System

UNIFORMAT II - Level I	UNIFORMAT II - Level II	UNIFORMAT II - Level III
D Services	D50 Electrical	D5010 Electrical Service and Distribution
D Services	D50 Electrical	D5020 Lighting and Branch Wiring
D Services	D50 Electrical	D5090 Other Electrical Systems

i) Technology System

UNIFORMAT II - Level I	UNIFORMAT II - Level II	UNIFORMAT II - Level III
D Services	D50 Electrical	D5030 Communications and Security

j) Fire and Safety System

UNIFORMAT II - Level I	UNIFORMAT II - Level II	UNIFORMAT II - Level III
D Services	D40 Fire Protection	D4010 Sprinklers
D Services	D40 Fire Protection	D4020 Standpipes
D Services	D40 Fire Protection	D4030 Fire Protection Specialties
D Services	D40 Fire Protection	D4090 Other Fire Protection Systems

k) Conversion: Stairs and Elevators System

UNIFORMAT II - Level I	UNIFORMAT II - Level II	UNIFORMAT II - Level III
C Interiors	C20 Stairs	C2010 Stair Construction (rec: struct)
C Interiors	C20 Stairs	C2020 Stair Finishes (rec: interior)
D Services	D10 Conveying	D1010 Elevators and Lifts
D Services	D10 Conveying	D1020 Escalators and Moving Walks
D Services	D10 Conveying	D1090 Other Conveying Systems

l) Conversion: Specialties

UNIFORMAT II - Level I	UNIFORMAT II - Level II	UNIFORMAT II - Level III
E Equipment and Furnishings	E10 Equipment	E1020 Institutional Equipment (rec:spec)
E Equipment and Furnishings	E10 Equipment	E1010 Commercial Equipment
E Equipment and Furnishings	E10 Equipment	E1030 Vehicular Equipment
E Equipment and Furnishings	E10 Equipment	E1090 Other Equipment
F Special Construction and Demolition	F10 Special Construction	F1010 Special Structures
F Special Construction and Demolition	F10 Special Construction	F1020 Integrated Construction
F Special Construction and Demolition	F10 Special Construction	F1030 Special Construction Systems
F Special Construction and Demolition	F10 Special Construction	F1040 Special Facilities
F Special Construction and Demolition	F10 Special Construction	F1050 Special Controls and Instrumentation

m) Others

UNIFORMAT II - Level I	UNIFORMAT II - Level II	UNIFORMAT II - Level III
E Equipment & Furnishings	E20 Furnishings	E2010 Fixed Furnishings
E Equipment & Furnishings	E20 Furnishings	E2020 Movable Furnishings
F Special Construction and Demolition	F20 Selective Building Demolition	F2010 Building Elements Demolition
F Special Construction and Demolition	F20 Selective Building Demolition	F2020 Hazardous Components Abatement

After unifying the building systems breakdown, FCI data are needed to compute the percentages of each system. A large amount of school facility condition data is publicly available online. Table 3.8 displays information about the school districts data used in this part of the research. The sample covers more than 191.5 million Square feet which is around 3% of national educational facilities total area.

Tables 3.9 and 3.10 show the distribution of the different school building systems percentages for school districts evaluated by MAPPS and the converted Uniformat II, respectively. The results for step 1 of stage 2 are shown in Table 3.11 where it presents the average of the school facilities systems percentages for both UNIFORMATT II & MAPPS. The cost was adjusted with a 1.5% inflation rate to reflect 2012 prices since reports used produced between year 2009 to 2012.

Table 3.8 School Districts Used for Developing Building Systems' Percentages Distribution

School District	Year	# of Facilities	Area GSF	System
U-46 Elgin School District	2009	65	5,837,763	MAPPS
St. Paul Public School District	2009	79	7,317,170	MAPPS
Baltimore City Public Schools	2012	163	17,482,340	MAPPS
Jeffco Public School District	2012	148	11,162,149	MAPPS
Caddo Parish Schools.	2010	79	7,059,215	Uniformat II
Colorado Department of Education	2010	1687	123,431,747	Uniformat II
DeKalb County School System	2011	151	1,439,6754	Uniformat II
Prince George's County School District	2012	186	16,016,428	Uniformat II
Total		2410*	191,541,417*	

*Jeffco Public SD data not included in the sum because it is included in the Colorado data.

Table 3.9 MAPPS Systems Distribution Percentages

District -Year	Saint Paul-2009	Baltimore 2012	Jeffco-2012	U46 -Elgin 2009	Total (2012 US\$) *	%
Site	10.0%	7.0%	17.4%	7.6%	\$239,019,373	9.4%
Roofing	3.9%	3.5%	2.0%	10.9%	\$107,184,848	4.2%
Exterior	0.2%	2.7%	3.7%	3.5%	\$68,470,791	2.7%
Structure	2.8%	0.3%	0.1%	3.8%	\$26,330,193	1.0%
Interior	18.1%	7.7%	19.3%	17.7%	\$316,654,162	12.4%
HVAC	16.3%	47.1%	11.1%	23.1%	\$857,833,885	33.6%
Plumbing	7.9%	6.0%	7.9%	8.3%	\$175,562,857	6.9%
Electrical	9.1%	5.2%	4.2%	10.0%	\$155,959,604	6.1%
Technology	14.3%	6.0%	7.5%	1.7%	\$174,432,720	6.8%
Fire and Safety	4.4%	5.7%	4.8%	3.8%	\$130,928,709	5.1%
Stairs and Elevators	0.9%	3.1%	1.4%	0.0%	\$54,722,826	2.1%
Specialties	12.1%	5.6%	19.8%	9.5%	\$243,714,928	9.5%
Other	0.0%	0.0%	0.7%	0.0%	\$3,340,171	0.1%
Total	100%	100.0%	100.0%	100.0%	\$2,554,155,067	100.0%

* Adjusted 2012 US dollars using 1.5 inflation rate

Table 3.10 Converted UNIFORMAT II Distribution Percentages

District-year	Caddo - 2010	Colorado-2010	Dekalb- 2011	Prince-2012	Total (2012 US\$) *	%
Site	19%	8.5%	15.2%	1.9%	\$1,050,150,869	8.1%
Roofing	3%	6.9%	3.8%	3.1%	\$773,002,142	6.0%
Exterior	8%	6.9%	6.6%	4.4%	\$842,100,615	6.5%
Structure	0%	0.1%	0.1%	0.1%	\$14,567,190	0.1%
Interior	22%	23.4%	17.8%	23.7%	\$2,979,710,505	23.1%
HVAC	5%	27.6%	20.5%	34.1%	\$3,554,367,187	27.6%
Plumbing	10%	7.6%	11.8%	8.6%	\$1,044,820,026	8.1%
Electrical	12%	9.6%	9.6%	11.6%	\$1,291,109,012	10.0%
Technology	0%	1.3%	3.8%	2.2%	\$202,201,688	1.6%
Fire and Safety	1%	4.0%	0.0%	3.5%	\$464,996,450	3.6%
Stairs and Elevators	1%	0.5%	0.1%	0.5%	\$65,577,051	0.5%
Specialties	14%	1.9%	6.5%	6.3%	\$424,021,693	3.3%
Other	4%	1.5%	4.2%	0.0%	\$194,666,716	1.5%
Total	100%	100.0%	100.0%	100.0%	\$12,901,291,144	100.0%

* Adjusted 2012 US dollars using 1.5 inflation rate

Table 3.11 Average School Facility's System Percentage (UNIFORMATT II & MAPPS)

System	Maintenance Needs (2012 US\$)*	percentage**	Weighted Average Life Expectancy	System Contribution To Overall age
	A	B=A/Total	C	D=B*C
Site	\$1,208,112,679	8.1%	25.0	2.025
Roofing	\$870,717,290	5.8%	15.1	0.8758
Exterior	\$893,341,205	6.0%	28.4	1.704
Structure	\$40,292,940	0.3%	99.7	0.2991
Interior	\$3,206,273,275	21.4%	21.5	4.601
HVAC	\$4,360,312,317	29.1%	25.0	7.275
Plumbing	\$1,183,481,367	7.9%	30.0	2.37
Electrical	\$1,427,309,609	9.5%	22.0	2.09
Technology	\$341,701,375	2.3%	10.0	0.23
Fire and Safety	\$573,496,157	3.8%	25.0	0.95
Stairs and Elevators	\$113,859,845	0.8%	32.7	0.2616
Specialties	\$575,314,483	3.8%	20.0	0.76
Other	\$194,666,716	1.3%	15.0	0.195
Total	\$14,988,879,258	100.0%		23.6365

* Adjusted 2012 US dollars using 1.5 inflation rate

** Jeffco Public School District data were removed because it is also contained in the Colorado Department of Education data.

Task 2: Estimating School Building Systems/Components Average Nominal Life

The following activities were conducted to achieve the aim of this step:

1. Compute the average useful life for every building's systems based on the sub-system weights and their nominal average useful life guidelines.
2. Compute the weighted average service life of school facilities as a whole using the results from the previous step.

The COMET/eCOMET system adapted the Building Owners and Managers Association (BOMA) standards for measuring the anticipated service life of building systems. Parsons Corporation (2010b –page17) presented a table with the expected service life in years for the different individual elements of systems (Unifomat- level III). That table was used in conjunction with the individual elements (Unifomat- level III) maintenance needs to compute the weighted average expected service life of MAPPS building systems using equation (3.5) and as shown in column C of Table 3.11. Using the same method, the average age for the whole building can be calculated using equation 3.6 and as shown in Table 3.11 column D and it is equal to 23.6 years.

$$\text{System useful life} = \text{SysL} = \sum(\text{SubL} \times \frac{\text{SubMN}}{\text{SysMN}}) \quad (3.5)$$

$$\text{Overall expected useful life} = \sum(\text{SysL} \times \frac{\text{SysMN}}{\text{Total MN}}) \quad (3.6)$$

Where:

SysL = System weighted average expected useful life

SubL= Subsystem expected useful life

SubMN=Subsystem maintenance needs

SysMN= System maintenance needs

Total MN = Total overall maintenance needs

Interior, HVAC, Electrical, and Site systems contributes up to 70% of the total maintenance needs and their USL ranges between (21.5 to 25 years) which can explain the resulted value of 23.6 years. An interesting observation is that the change in deterioration patterns from Markov chain method shown in Figure 3.10 happens around the same average USL computed in stage 2 that is 23years.

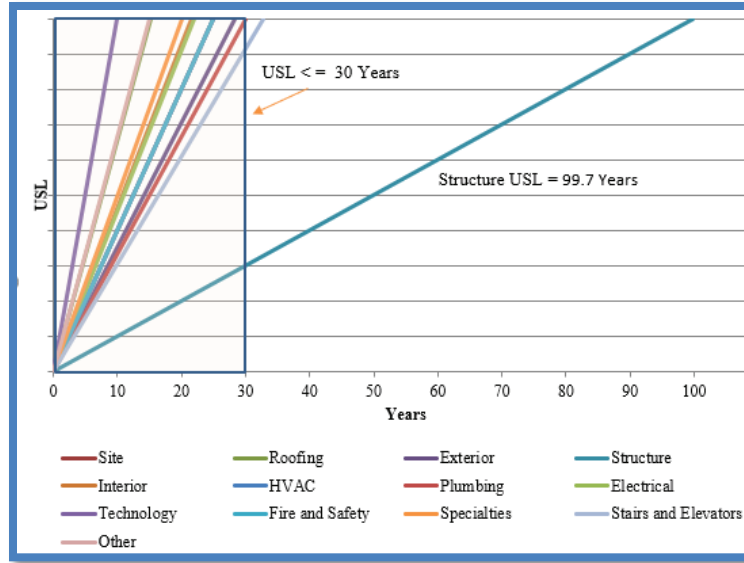

Figure 3.12 School Facility's Systems Weighted Average Life Expectancy Plots

3.5.3 Stage 3: Determine Deterioration Rate Boundaries for Educational Facilities

Task 1: Develop an Overall Deterioration Model for Educational Facilities

This task aims to plot the deterioration curve for well-maintained educational facility based on its components' service life, life cycle renewals and the percentages of these components as shown in Table 3.11 and Figure 3.12. Developing an overall deterioration model for educational facilities starts with evaluating the annual condition of school facility as whole. The annual condition during the USL period for the facility can be calculated as:

$$\text{Annual FCI (time } j) = \sum_i \left(\left(\frac{\text{USL Percentage}}{\text{Expected life } i} * \text{age } j \right) * \text{percentage } i \right) \quad (3.7)$$

Where:

i = represents school facilities different systems (site, roofing, exterior, structure, etc.).

USL Percentage = the minimum acceptable FCI at the end of USL provided doing the recommended maintenance. It is assumed to be 40 according to FCI guidelines for good condition.

Age j = represents system i age at time j . Note that system i is replaced at the end of its USL.

Percentage = the percentage of the system i as shown in 3.11 column B.

Expected life = the system i expected life as shown in Table 3.11 column C.

At the end of the USL period for each building system, the age will be reset, and the system is assumed to be renewed.

Task 2: Analyze and Simplify the Resulted Curve Through Linear Regression and Defining Range

The resulted plot from task one is shown in Figure 3.13a. If we take the first linear segment (shown in figure 3.13b), we will see that the slope is equal to 1.6 which means that the building is deteriorating 1.6% annually with doing the proper maintenance. Since the recommended maintenance percentage is 2% according Filardo (2016), it can be assumed that the annual deteriorating rate without doing the proper maintenance is 3.6%. Markov chain deterioration curve (Figure 13.10) from Stage 1 showed that the deterioration pattern was changed at age 23, and the FCI was approximately 55%. That means the annual deterioration rate can be assume 2.4%/year. Table 3.12 show the results summary and the values that can be used to create a simplified linear overall condition prediction model for school facilities. Based on these findings, the overall deterioration curves in Figure 3.14 were plotted representing no maintenance, real world, and with maintenance cases. The proposed limits are valid for building age starting from 0 to 23 years. Beyond 23 years, the building need major renovation since three major building systems: Interior, HVAC, and Electrical which contributes around 60% of the total maintenance needs reached their USL limit.

Table 3.12 Average Educational Facility Deterioration Rate

Source	Stage 1 Markov Chain	Stage 2 Results	Stage 2 Results
Case	Deferred Maintenance (Real World Data)	Recommended Maintenance	Without Maintenance
FCI at year 23	55%	36.8%	82.8%
Annual Deterioration Rate (first 20 years)	2.4%	1.6%	3.6%

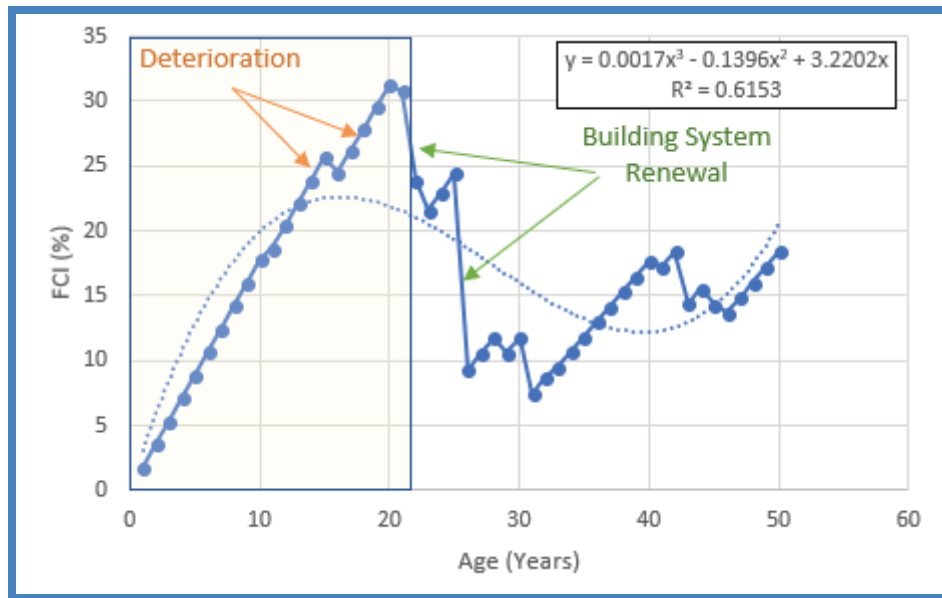

a) General View

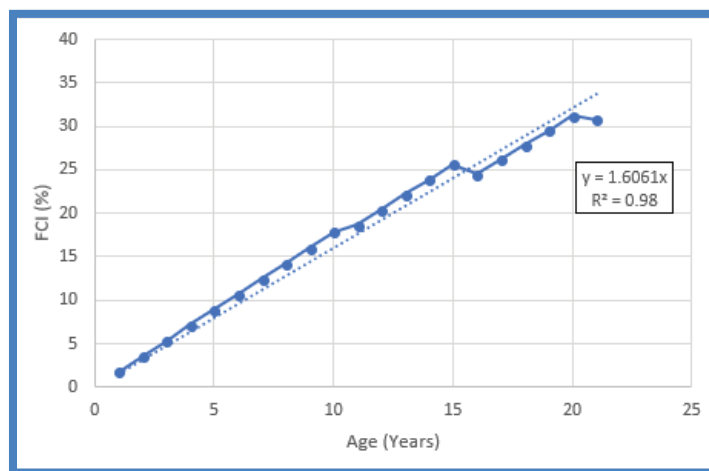

b) Close-up

Figure. 3.13 Overall Educational Facility Deterioration Curve
(With Proper Maintenance and Life Cycle Renewals)

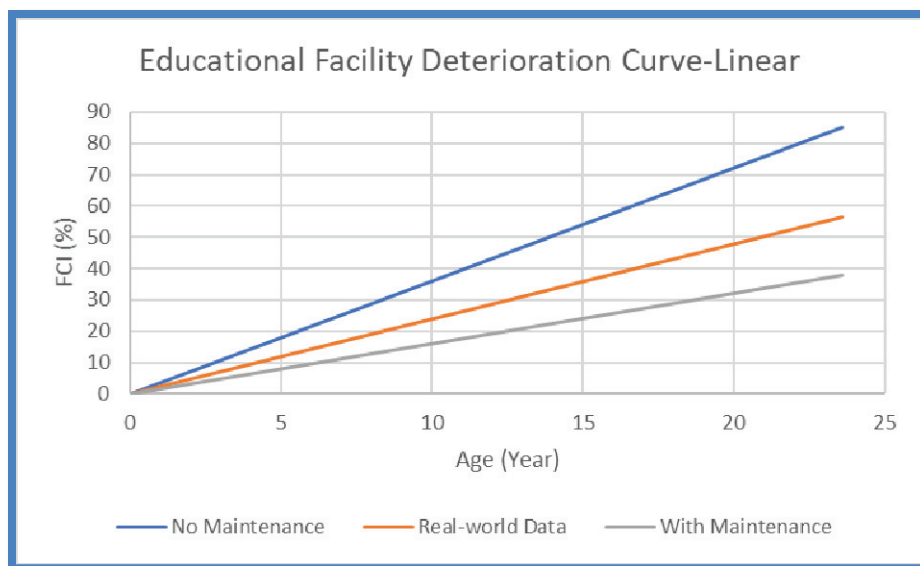

Figure. 3.14 Simplified Educational Facility Deterioration Curve

3.6 Summary

This Chapter presented an overall condition prediction modeling methodology framework for complex facilities aiming in enhancing maintenance decisions. Facility condition index (FCI) assessment data were used to test the applicability of the developed deterioration modeling methodology.

The proposed methodology is a three-stage approach starting with the development of Markov chain deterioration model using three-year FCI data from Prince George's County Public Schools (PGCPS) to recognize the deterioration pattern of educational facilities as a whole. The next stage was determining the useful service life of the school building by using schools' maintenance needs costs and the average USL of the school building components. The last stage aimed to recognize the upper and lower deterioration rates boundaries by plotting and analyzing the best scenario deterioration curve assuming doing the recommended maintenance and renewals. The resulted curve was compared to Markov chain model results, and the limits were evaluated by investigating the recommended maintenance values for school buildings.

Defining the deterioration rate limits help to construct a simple linear regression deterioration model that can be used for evaluation maintenance needs for school building as whole using the gross area and current replacement value.

CHAPTER 4. AGENT-BASED TACTICAL DECISION-SUPPORT SYSTEM FOR EDUCATIONAL FACILITIES MANAGEMENT: CLASSROOM INTERACTIONS MODELING

4.1 Overview

Modeling human behavior and its uncertainties is relatively new in the context of civil engineering and asset management. Most of the published research to date in those areas relates to developing a human behavior prediction model of the effects that building occupants have on energy consumption (Lee, 2013). However, more recent advances in computer simulation and the development of agent-based modeling capabilities now make it possible to model complex human behavior and its inherent uncertainties (Malkawi et al., 2004). Chapters 4 and 5 of this research report propose a tactical and strategic level agent-based simulation modeling process as a tool to support decision-making in the area of asset management.

This chapter presents the tactical level agent-based simulation for the management of HVAC systems in school facilities. As shown in Figure 4.1, the chapter is divided into four main sections. First, the introduction explains the model's objectives in addition to illustrating the reasons behind selecting the HVAC system for the tactical level model. Then, a literature review presents the published knowledge about the relation between the indoor environmental quality (IEQ) and student health and performance. Also, the HVAC system is explored as well as some basic information that can help in the modeling process. Later, the system of systems (SoS) modeling methodology is discussed, starting with the definition phase, followed by the abstraction phase, and ending with the implementation phase. In the implementation phase, the case study used to prove the applicability of the proposed model and its verified results are discussed. Chapter 4 closes with an explanation of the validation and verification methods utilized as well as our summary and conclusions.

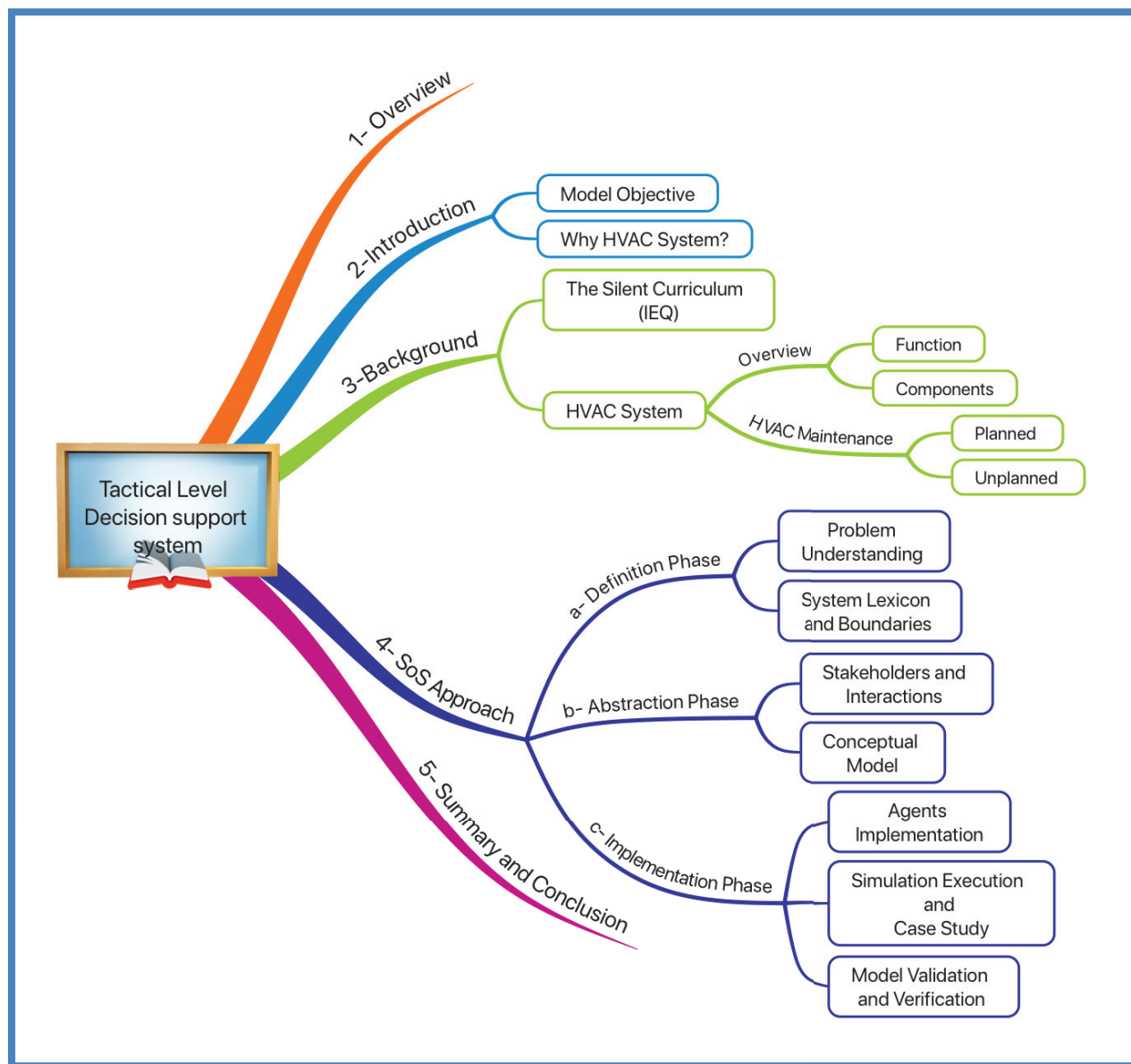

Figure 4.1 Tactical Level ABM Mind Map

4.2 Introduction

There is a mutual relationship between the occupants of school buildings (students, teachers, and staff) and the condition of the facilities. The literature review in Section 2.3 presented the effect of school condition on students' performance and achievement as well as how the behavior of its occupants affects the condition of the facilities. The school building deterioration rate is known to accelerate due to overcrowding, misuse, or vandalism. The objective of developing a tactical level ABS (TL-ABS) model for classroom interactions is to capture and model the two-way relationships between the system stakeholders. The developed model can be used to gain a better and more comprehensive understanding of the problem and provides decision-makers with a tool to embrace a more proactive management style rather than a reactive one. Decisions made without this systemic understanding of the school system and the effect of the different operating and maintenance strategies on the psychological, physiological, social, environmental, and economic aspects could have negative impacts on the school district as a whole, such as higher property taxes, increased assets deterioration rates, more health and safety issues, and even changes in population patterns.

For the TL-ABS model, the HVAC system of school facilities was selected to demonstrate its effect on the whole building system for the following reasons:

- Approximately 20 percent of the U.S. population spends a significant amount of time each day inside school buildings. Approximately 50 percent of these schools have indoor air quality problems, which has been strongly linked to health problems and lower performance. (National Research Council, 2006; U.S. Environmental Protection Agency (USEPA), 2009)
- The main objective of using a HVAC system and artificially conditioning school buildings is to produce comfortable air quality and thermal conditions for students, teachers, and staff. HVAC systems have direct and immediate effects on the occupants' health and performance. A large body of research has been conducted over the years to investigate the effect of thermal quality and indoor air quality on human productivity in general and on student health and performance in particular.

- One of the powerful features of agent-based modeling is the ease of capturing the two-way relationship between the HVAC system and the school's occupants. A good example is the increase of thermostat probability of failure (Pof) due to misuse or vandalism by dissatisfied students.
- Failing to maintain HVAC systems as recommended by manufacturers can cause serious problems, such as increased system downtime and repair costs and reduced equipment service life and energy efficiency.
- HVAC systems are responsible for a large percentage of the operation and maintenance cost of buildings. According to the U.S. Energy Information Administration (EIA), HVAC systems consume almost half of the entire energy used in U.S. buildings (Wang, 2014).
- As with any other energy-consuming equipment, HVAC systems should be upgraded or replaced before the end of their useful service life to comply with new standards and regulations, which can create unplanned financial burdens on school districts.

4.3 Background

4.3.1 The Classroom Indoor Environment: The Silent Curriculum

School facilities are essential to the advancement of effective teaching and learning. Taylor and Vlastos (Taylor, 2009) used the term “silent curriculum” to describe the effect of the classroom physical environment on the education outcomes of students. A large body of research has been conducted to explore the factors affecting student performance. As described earlier in Section 2.3, student academic achievement was linked to teacher performance (Rivkin et al., 2005; Nye et al., 2000; Sanders et al., 1996); socioeconomic status (SES) factors such as parents' education levels, ethnicity, income, and home conditions (Sirin, 2005; Peng et al., 1994); students' personal qualities and peer relations, (Fuligni, 1997; Leiter, 1983); and school facilities.

In the case of school facilities, environmental researchers concluded that improved indoor environmental quality (IEQ) in schools will result in improved health, decreased absenteeism, improved performance, and reduced operational cost (Johnson, 2005; Schulte et al., 2005; Shendell et al., 2004; Norbäck et al., 2000; Leach, 1997).

IEQ is a broad concept describing the condition inside a facility (REHVA, 2010). IEQ is a critical factor for delivering a safe, healthy, and comfortable learning environment. In the context of educational facilities, IEQ covers many aspects, such as classroom temperature, relative humidity, air flow rate, air quality, noise level, and lighting (Almeida et al., 2015). In other words, IEQ can be defined as the sum of the thermal comfort (TC), indoor air quality (IAQ), acoustic comfort (AC), and visual comfort (VC) as shown in Figure 4.2 (Almeida et al., 2015; Alfano et al., 2010). The first fundamental factor of IEQ is the thermal comfort (TC). Fanger (1970) defined TC as “the state of mind in which a person expresses satisfaction with the thermal environment.” TC is a subjective concept that is different for each person and is influenced by many factors including clothing insulation, metabolic rate, air temperature, air velocity, relative humidity, and psychological parameters such as expectations (De Dear et al., 1998).

Indoor air temperature is the most frequently used thermal quality indicator in IEQ and performance studies. Other thermal quality indicators were used in similar research and include Kalz et al., 2014; Cui et al., 2013; Charles, 2003; De Dear et al., 1998; and Fanger, 1970.

1. The predicted mean vote (PMV) is a thermal scale that ranges from cold (-3) to hot (+3). PMV is computed using Fanger’s equation.
2. The thermal sensation vote (TSV) is a thermal sensation scale that ranges from cold (-3) to hot (+3). TSV is determined by survey methods.
3. The thermal comfort vote (TCV) is the degree of satisfaction with the thermal conditions, using a range from comfortable (0) to extremely uncomfortable (4).

Wyon and Wargocki (2006) conducted a literature review study on the effects of room temperature on office workers and concluded that “thermal discomfort distracts attention and generates complaints,” and “warmth lowers arousal, exacerbates sick building syndrome (SBS) symptoms and has a negative effect on mental work” (Wargocki and Wargocki, 2013). Similar or worse effects can be predicted on children and their academic performance. Unlike adults, children are more vulnerable because the work they are required to perform in school is mostly new to them, they do not have the freedom to change the classroom or change the school, and they do not have control over their school environment. (Wargocki and Wargocki, 2013; Mendell et al., 2005; Wyon and Wargocki, 2006)

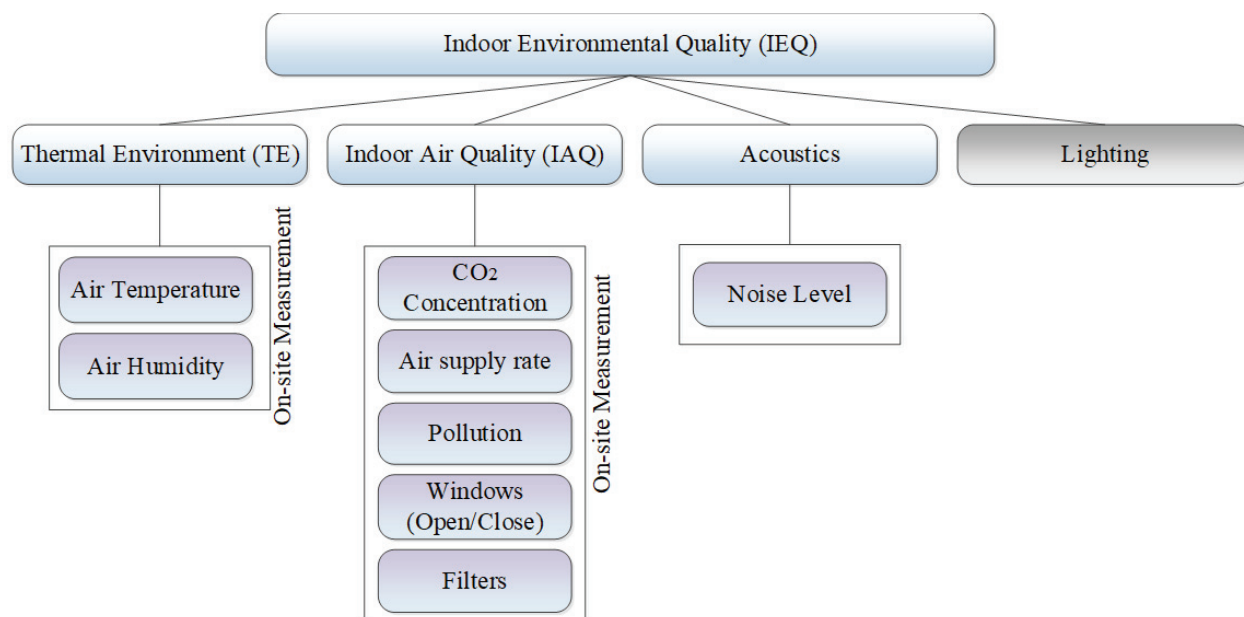

Figure 4.2 IEQ Factors and Measurements

Many past studies that investigated the relationship between classroom temperature and student health and performance generally indicated that small changes in classroom temperature, even within the comfort zone range, can disturb children’s concentration and affect their ability to complete mental tasks such as mathematics and sentence comprehension. In general, higher temperatures have the tendency to reduce performance and increase adverse health symptoms, while lower temperatures affect the speed at which tasks are completed (Fang et al,1999; Fang et al, 1998; Levin,1995; Wyon,1991; Wyon et al,1979).

The second fundamental factor is the indoor air quality (IAQ), which is a critical factor for ensuring a healthy and comfortable learning environment for students. The U.S. EPA (2016) defined IAQ as “the air quality within and around buildings and structures, especially as it relates to the health and comfort of building occupants.” A good indoor air quality space is one that is well ventilated, low in carbon dioxide and pollutant concentrations, and low in odor intensity. The reviewed literature pertaining to IAQ indicators can be summarized as follows: carbon dioxide concentration, pollutant concentrations, ventilation rate, odor intensity, and perceived air quality (PAQ) as shown previously in Figure 4.2. Higher air pollutant concentrations can cause long-term health issues, such as asthma, as well as respiratory infections and short-term health issues such as

headaches, nasal congestion, eye and skin irritations, coughing, sneezing, fatigue, dizziness, and nausea (often grouped together as sick building syndrome (SBS)) (Filardo, 2016; Joshi, 2008).

Furthermore, the combination of poor IAQ and higher temperatures may increase the discomfort levels and negatively affect students' concentration and performance (Filardo, 2016). Absenteeism because of respiratory illness also is well documented and clearly shows that school absenteeism is higher among asthmatic and allergic students rather than healthy children (Mendell & Heath, 2005).

Filardo (2016) concluded that IAQ problems can accelerate building deterioration, force schools to close, generate liability issues, and affect the relationships between parents, teachers, and the school administration.

The third fundamental factor is acoustical comfort (AC), which is affected by the presence of unwanted noise in the facilities, such as faulty HVAC equipment, street noise, or the conversations of others. AC is very important in schools, mainly because most classroom activities are based on verbal communication, which requires low noise levels. Higher noise levels for a long period of time may result in fatigue, higher stress and lower concentration levels, and lower performance for students as well as teachers. (Paradis, 2014; Pavčerková et al., 2009)

The fourth and last fundamental factor is the visual comfort (VC), which is out of the scope of this research since it is not affected by HVAC system failures. Figures 4.3 a & b summarize the human factors attributes measured in the IEQ research.

Tables 4.1 to 4.4 summarize the relationships between the IEQ factors within the classroom environment in schools and the students' health, satisfaction, and academic performance.

Tables 4.5 summarize the studies that examined the relations between the IEQ factors and the students' health, performance, and behavior.

Tables 4.6 to 4.9 summarize the studies that examined the relations between the IEQ factors and the employees' health, performance, and behavior.

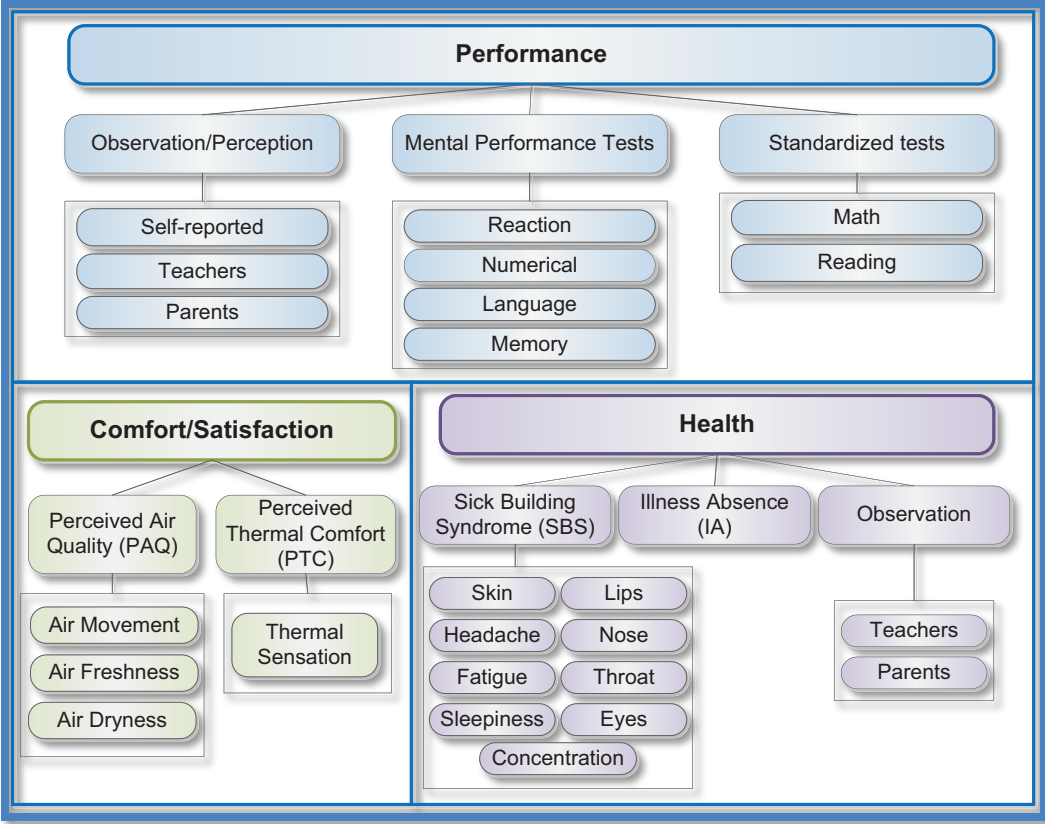

a) Summary of the Student Attributes Studied in IEQ Research

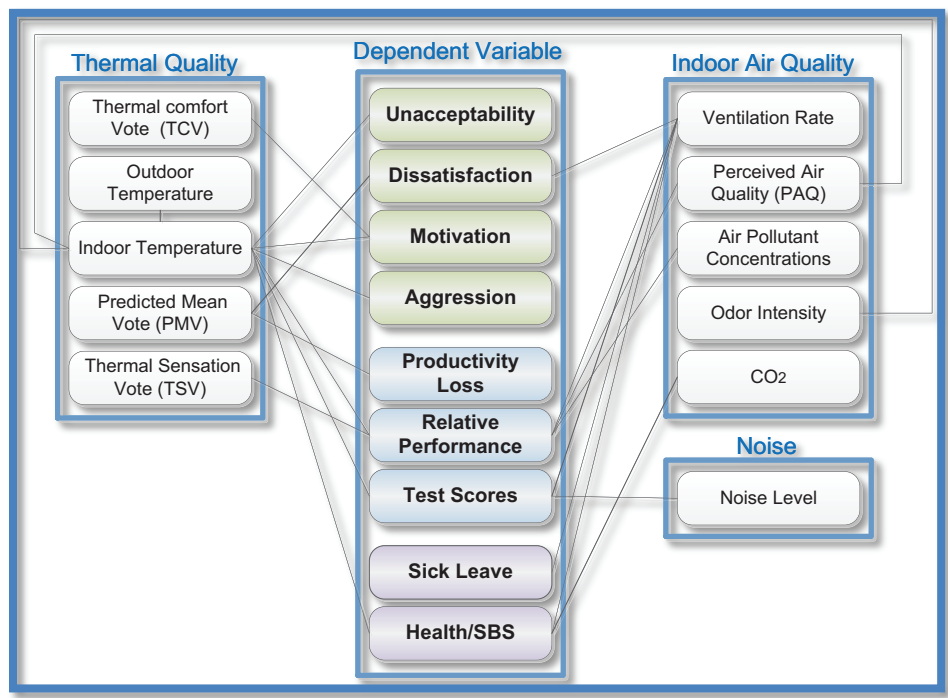

b) Human-dependent Attributes and Their Relation to the IEQ Factors in the Literature

Figure 4.3 Human Factors Studied in the IEQ Research.

Table 4.1 Summary of the Studies That Examined the Relations Between Classroom
Ventilation and Student Performance

Test Type	Relation	Research
Standardized Test Scores		
General	Significant	Myhrvold et al. (1996)
General - speed	Significant	Wargoeki & Wyon (2007)
General	Significant	Goto & Ito (2009)
Numerical Based	Significant	Shaughnessy et al. (2006)
Numerical Based	2.90%	Haverinen-Shaughnessy et al. (2011)
Language Based	2.70%	Haverinen-Shaughnessy et al. (2011)
Mental Performance Tests		
Choice Reaction	2.20%	Bakó-Biró et al. (2012)
Numerical Based	Significant	Wargoeki & Wyon (2007)
Language Based	15%	Bakó-Biró et al. (2012)
Memory Based	8%	Bakó-Biró et al. (2012)

Table 4.2 Summary of the Studies that Examined the Relations Between Classroom
Temperature and Student Performance

Test Type	Relation	Research
Standardized Test Scores		
General	5.70%	Schoer and Shaffran (1973)
General - speed	Significant	Pepler & Warner (1968)
General	Significant	Holmberg & Wyon (1967)
Mental Performance Tests		
Numerical Based	Significant	Wyon et al. (1979)
Numerical Based	Significant	Wargoeki & Wyon (2007)
Numerical Based	4%	Haverin-Shaughnessy & Turunen (2012)
Numerical Based	Significant	Holmberg & Wyon (1967)
Language Based	Significant	Wyon et al. (1979)
Language Based	Significant	Wargoeki & Wyon (2007)
Language Based	Significant	Holmberg & Wyon (1967)
Memory Based	Significant	Wyon et al. (1979)

Table 4.3 Summary of the Studies that Examined the Relations Between the Classroom IEQ Variables and **Student Health**

Health Aspect	IEQ Variable	Relation	Research
Health - General	Ventilation	Significant	Myhrvold et al. (1996)
Respiratory- Asthma	Ventilation	Significant	Smedje et al. (1997)
Illness Absence (IA)	Green school	2 to 7.5%	Issa et al. (2011)
Illness Absence (IA)	Ventilation	Significant	Haverin-Shaughnessy & Turunen (2012)
Illness Absence (IA)	Ventilation	10 to 20%	Shendell et al. (2004)
SBS- Runny nose	Ventilation	7.30%	Turunen et al.,(2014)
SBS-Fatigue	Ventilation	7.70%	Turunen et al.,(2014)
SBS-Fatigue	Temperature	Significant	Holmberg & Wyon (1967)
SBS-Headache	Ventilation	Significant	Haverin-Shaughnessy & Turunen (2012)
SBS-Headache	Ventilation	5.50%	Turunen et al.(2014)
SBS-Concentration	Ventilation	Significant	Haverin-Shaughnessy & Turunen (2012)

Table 4.4 Summary of the Studies that Examined the Relations Between the Classroom IEQ Variables and **Student Satisfaction**

Dependent Variable	IEQ Variable	Relation	Research
Satisfaction Level	Noise	11%	Turunen et al.,(2014)
Satisfaction Level	IAQ	7%	Turunen et al.,(2014)
Satisfaction Level	IAQ	Significant	Wargocki & Wyon (2007)

Table 4.5 Summary of the Studies that Examined the Relations Between the Classroom IEQ Variables and Student Performance, Health, and Satisfaction

Study	Sample	IEQ Variable	Dependent Variable
Wyon et al. (1979)	36 males and 36 females 17-year old - in climate controlled chamber. (Netherlands)	Temperature range: 20 - 29°C	<ul style="list-style-type: none"> • Mental performance: Sentence comprehension, Multiplication, Word memory.
Myhrvold et al.(1996)	550 students from 22 classrooms in 5 schools (Norway)	Carbon Dioxide	<ul style="list-style-type: none"> • Reaction time SPES test (30min computerized test): 1- Simple reaction time. 2- Choice reaction time. 3-Color word vigilance. • Questionnaire (17 Q) about pupils' health & social climate.
Smedje et al. (1997)	627 pupils in the seventh in 11 randomly chosen schools. (Sweden)	Particles pollution.	<ul style="list-style-type: none"> • Questionnaire (asthmatic symptoms, other health aspects).
Shendell et al. (2004)	409 traditional and 25 portable classrooms from 22 schools located in six school districts. (USA)	Carbon Dioxide	<ul style="list-style-type: none"> • Student attendance level.
Shaughnessy et al. (2006)	Fifth grade classrooms in 54 elementary schools (USA)	Carbon Dioxide	<ul style="list-style-type: none"> • Standardized aptitude tests.
Wargoeki & Wyon (2007)	10- to 12-year-old children in two classes. (Denmark)	Used/ new air filters & Carbon Dioxide	<ul style="list-style-type: none"> • Seven exercises exemplifying different aspects of schoolwork (numerical or language-based) • visual analogue scales to indicate the intensity of any health symptoms. • visual analogue scales to indicate their environmental perceptions.

Table 4.5 Continued

Study	Sample	IEQ Variable	Dependent Variable
Bakó-Biró et al. (2007), Bakó-Biró et al. (2008), Clements-Croome et al. (2008), Bakó-Biró et al. (2012).	2 classrooms in 8 primary schools for 3 weeks (England)	Carbon Dioxide	<ul style="list-style-type: none"> • Computerized performance tasks.
Wargocki & Wyon (2007)	10- to 12-year-old children in two classes.(Denmark)	<p>Low and high temperatures,</p> <p>Low and high ventilation rate, & Carbon Dioxide</p>	<ul style="list-style-type: none"> • Normal schoolwork. • Seven exercises (numerical or language-based) • Parents and teachers' observations of children's health, mood, and changes in behavior. • Environmental perception (classroom temperature, air movement, air dryness, air freshness, illuminance and noise). • Health symptoms perception (nose congestion, throat, lip, and skin dryness, eyes hurting, hunger, fatigue, sleepiness, and headache).
Norbäck & Nordström (2008)	355 University students (31% women)- in 4 classrooms. (Sweden)	Carbon Dioxide, and Particles pollution	<ul style="list-style-type: none"> • Air Quality Perception.
Goto & Ito (2009)	2 technical colleges. (Japan)	<p>3 levels indoor temperature (22, 25, 28°C) & 3 levels outdoor air supply rate (5, 10, 20m³/h/person)</p>	<ul style="list-style-type: none"> • Performance: 30-min examination after a 180-min video lecture
Haverin-Shaughnessy et al. (2011)	One fifth grade classroom in 100 elementary schools USA)	Carbon Dioxide	<ul style="list-style-type: none"> • Standardized test scores.

Table 4.5 Continued

Study	Sample	IEQ Variable	Dependent Variable
Haverin-Shaughnessy & Turunen (2012)	Sixth grade students in a random sample of 334 school. (Finland)	Questionnaire (school principals) & Site-inspections	<ul style="list-style-type: none"> • Mathematics score. • Health questionnaires.
Toyinbo (2012)	1000 sixth grade students from 59 schools (Finland)	On-site Temperatures & Ventilation rates.	<ul style="list-style-type: none"> • Mathematics test scores as a part of a national assessment program. • Health questionnaires.
Mendell et al. (2013)	162 3rd–5th-grade classrooms in 28 schools in three school districts. (USA)	Carbon Dioxide	<ul style="list-style-type: none"> • Illness absence (2 years).
Gao et al. (2014)	Four classrooms in single school in suburban - one month (2 seasons) (Denmark)	Carbon Dioxide	<ul style="list-style-type: none"> • Acute health-related symptoms.
Turunen et al. (2014)	Sixth grade students- in 56 schools. (Finland)	On-site Temperatures & Ventilation rates.	<ul style="list-style-type: none"> • Self-reported health symptoms. • Perceived IEQ.

Table 4.6 Summary of the Studies that Examined the Relations Between IEQ and Employee Performance

IEQ Variable	Relationship with Performance	Research
Temperature-Warm	5 to 7% reduction	Niemela et al. (2002)
Temperature-Warm	2% reduction / C (over 25C)	Seppanen et al. (2003)
Temperature-Warm	8.9% reduction	Seppanen et al. (2006)
Temperature-Warm	Significant	Bell (1981), Federspiel et al. (2002), Tham, (2004), Seppanen et al. (2006), Tanabe et al. (2007), Lan et al. (2011), Lan et al. (2012), Cui et al. (2013), Lan et al. (2014)
Temperature-Cold	Significant	Lan et al. (2012), Cui et al. (2013)
Temperature + Noise	56% more errors	Witterseh et al. (2004)
Ventilation	1.7% improvement with higher ventilation rate, performance increases by 1.5% per 10% dissatisfaction reduction	Wargocki et al. (2000)
Ventilation	1.9 % improve	Wargocki et al. (2000)
Ventilation	9% reduction	Bakó-Biró et al. (2004)
Ventilation	Significant	Tham (2004)

Table 4.7 Summary of the Studies that Examined the Relations Between IEQ and Employee Health

IEQ Variable	Relationship with Health and SBS	Research
Temperature-Warm	Linear correlation between Temperature and SBS syndrome	Jaakkola et al. (1989)
Temperature-Warm	12% increase per °C above 22.5 °C	Seppanen et al. (2006)
Temperature-Warm	Significant	Fang et al. (2002), Fang et al. (2004), Witterseh et al. (2004), Tanabe et al. (2007), Lan et al. (2011)
Ventilation	Significant	Tham (2004)

Table 4.8 Summary of the Studies that Examined the Relations Between IEQ and Employee Satisfaction

IEQ Variable	Relationship with Satisfaction	Research
Temperature-Warm	Lower thermal acceptability- Significant	Witterseh et al. (2004), Fang et al. (2004)
Temperature-Warm	Perceived air quality (PAQ) – Significant	Witterseh et al. (2004), Lan et al. (2011)
Ventilation	Perceived air quality (PAQ) – Significant	Bakó-Biró et al. (2004), Kaczmarczyk et al. (2004)

Table 4.9 Summary of the Studies that Examined the Relations Between IEQ and Employee Behavior

IEQ Variable	Relationship with Behavior & Mood	Research
Temperature-Warm	Motivation – Significant	Lan et al. (2011), Cui et al. (2013)
Temperature-Warm	Aggression – Significant	Bell (1981)
Temperature-Warm	Negative mood – Significant	Lan et al. (2011)
Temperature-Warm	Helping behavior – Significant	Bell (1981)

4.3.2 HVAC Systems:

4.3.2.1 Overview of HVAC Systems

HVAC systems have two main functions: thermal control and ventilation. HVAC systems control thermal comfort, humidity, and IAQ in school buildings, which is critical for ensuring student and teacher health and satisfaction in addition to enhancing their performance. The condition of HVAC systems strongly affects the IEQ in schools, which in turn could affect the health and performance of students as discussed in the previous section (Mendell & Heath, 2005).

A typical HVAC system mainly consists of several mechanical and electrical parts, such as vents, ducts, thermostats, compressors, motors, fans, pumps, and pipes (Khan, 2003). ASTM Unifomat II Classification for Building Elements divided HVAC systems into the nine subdivisions shown in Table 4.10 (Charette, 1999).

Table 4.10 ASTM Unifomat II Classification for the HVAC System (Charette, 1999)

Level one	Level Two	Example
D30 HVAC	D3010 Energy Supply	Gas supply system
	D3020 Heat Generating Systems	Boilers
	D3030 Cooling Generating Systems	Chillers
	D3040 Distribution Systems	Air distribution systems
	D3050 Terminal & Package Units	FCU
	D3060 Controls & Instrumentation	Automation systems
	D3070 System Testing & Balancing	Piping testing and balancing
	D3090 Other HVAC Systems & Equipment	Air purifiers

HVAC system is a simple system that consists of a series of heat exchanging loops using air, water, and/or refrigerant. There are several HVAC system combinations that generally are used in schools. A popular HVAC system combination may consist of a chiller for cooling, a boiler for heating, and fan coil units (FCU) or air handling units (AHU) for air circulation. The HVAC system that will be used for our simulation is shown in Table 4.11 and Figure 4.4 below.

Table 4.11 HVAC System Configuration

Equipment Type	Equipment
Heating equipment	Gas fired Boilers and pumps
Cooling equipment	Water cooled chillers with cooling tower and pumps
Air supply equipment	Fan coil units (FCU) for classrooms & Air handling unit (AHU) for open spaces
Air distribution equipment	Ducts & GRDs (for the AHU)

The simulation in this paper focuses on the classroom environment. In that context, the HVAC system can be divided into three main parts:

1. Cooling sub-system:

Cooling sub-system includes three main parts:

- Water-cooled chillers. Chillers are used to produce chilled water which is transferred through pumps to the FCUs in classrooms. Chillers are the most expensive part of the whole HVAC system; therefore, a high level of failure protection mechanisms are used to ensure safe and efficient operation. Chiller failure protection mechanisms include pressure and temperature sensors that normally shut down the whole system in case of a failure (Capehart et al, 2006).
- Water pumps. Pumps are used for water circulation throughout the system.
- Cooling towers (CT). Cooling towers are heat rejection equipment that rejects heat to the atmosphere.

1- Heating sub-system:

Heating sub-system includes two main parts:

- Gas fired boilers. Boilers are used to produce the hot water used in the FCU for heating.
- Water pumps. Pumps are used for water circulation.

2- Air distribution sub-system:

FCUs are used for air distribution and circulation in the classrooms. FCUs deliver cold and hot clean air by using a fan to move air through filters and coils and into the classroom. As the name suggest, the FCU is composed of the following basic parts (Capehart et al, 2006):

- Fans are used for air circulation.
- Coils are responsible for heat exchange.
- Filters remove pollutants from the air.
- Thermostats regulate the operation of the FCU.

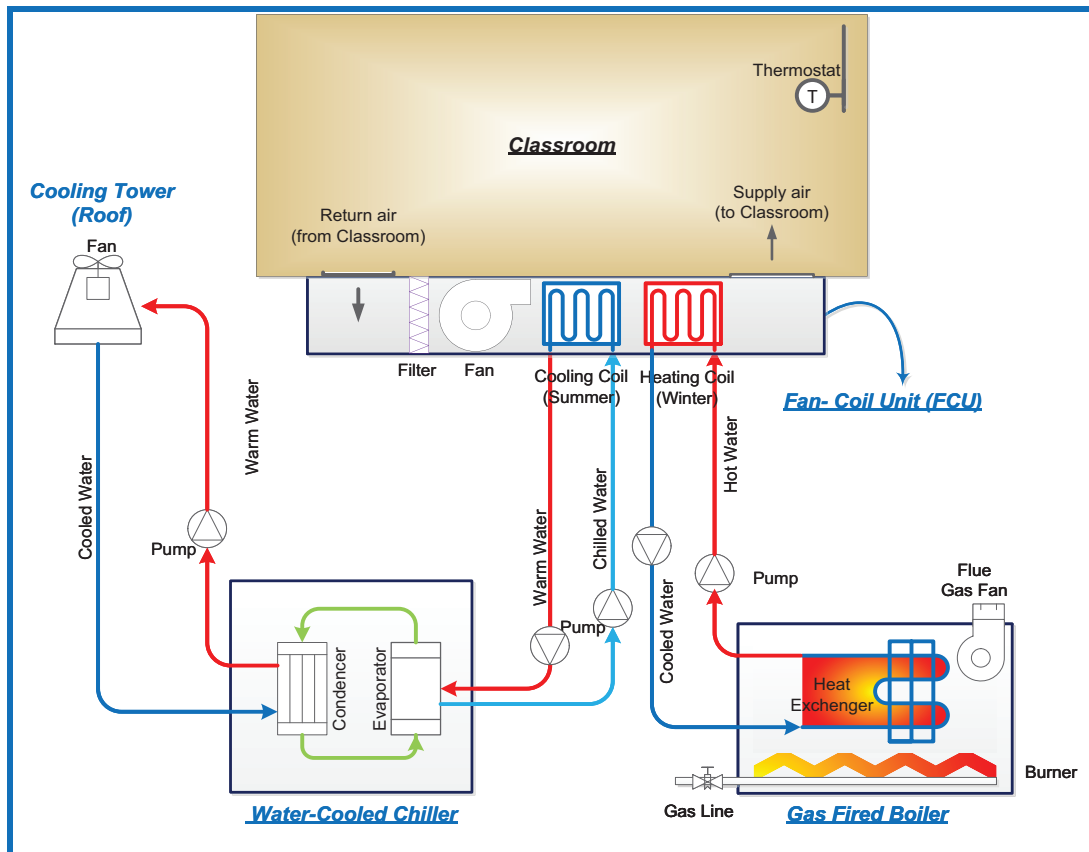

Figure 4.4 The HVAC System Used in the Research

4.3.2.2 HVAC System Maintenance and Energy Consumption

According to the ASHRAE HVAC Applications Handbook (2011), the cost of operations and maintenance (O&M) can represent as much as 60% to 85% of the total life-cycle cost for nonresidential buildings. The U.S. EPA (2008) reported that more than 65% of a school's energy costs is related to the HVAC system. Moreover, the HVAC system alone is responsible for up to 30% of the total cost of school building maintenance and repair (Abate et al., 2009). Therefore, it

is extremely critical to select the most cost-effective maintenance level for HVAC systems taking into consideration both the short and long-term cost-effectiveness.

The British Standards Institution (1993) defines maintenance as “the combination of all technical and administrative actions, including supervision actions, intended to retain an item in or restore it to a state in which it can perform a required function.” Maintenance can be classified into planned maintenance (proactive and preventive), and unplanned or reactive maintenance (ASHRAE, 2011). Proactive maintenance focuses on monitoring the system using high level testing equipment like infrared thermography and vibration analysis to identify and fix problems before failure occurs. Proactive maintenance is the optimal approach for critical systems but the most expensive one. On the other hand, preventive maintenance is a set of scheduled tasks, such as cleaning, lubricating, calibrating, inspecting, and even replacing parts (e.g. filters), to help the equipment reach its useful service life in good condition. (Capehart et al, 2006; ASHRAE, 2011).

Unplanned maintenance, also called run to failure maintenance (RTF), can be further subdivided into emergency maintenance and breakdown maintenance. Emergency maintenance require immediate attention because the failure could result in catastrophic situations or safety issues (ASHRAE, 2011). Breakdown maintenance is the second type of unplanned maintenance. Breakdown maintenance includes the repairs performed after a failure occurs to restore the equipment to its functional condition (Capehart et al, 2006; ASHRAE, 2011).

Wang & Hong (2013) categorized HVAC maintenance practices into three levels based on their literature review and discussions with HVAC engineers, building operators, and facility managers: proactive maintenance, preventive maintenance, and reactive unplanned maintenance. Different HVAC maintenance practices can lead to significant differences in energy use, short-term and long-term maintenance costs, and the actual useful service lives of the HVAC components. Table 4.12 summarize the relation between maintenance practices levels and their effect on USL, cost, efficiency, and energy consumption (Wang et al., 2013). For example, reactive unplanned maintenance is normally used by underfunded facilities because it has low short-term cost, but it reduces the system efficiency and in turn reduces the expected useful life. It also increases energy consumption and the overall life cycle cost of the system.

Table 4.12 Wang & Hong (2013) HVAC Maintenance Practices Types

Maintenance Approach	Low	Medium	High
Reactive	Eff, L, STC	--	E, LCC
Preventive	--	Eff, L, STC, E, LCC	--
Predictive	E, LCC	--	Eff, L, STC

Eff=HVAC Efficiency; E=Energy Consumption; L= HVAC Life;

STC=Short-term Costs; LCC=Life Cycle Costs

4.4. System of Systems (SoS) Modeling Approach and Methodology

Different authors have offered slightly different criteria for identifying a SoS. Maier (1998), for example, proposed five distinguishing traits of a SoS: operational and managerial independence of the system components, geographic distribution, evolutionary and emergent behaviors. Of those five traits, Maier highlighted operational and managerial independence as the two key SoS traits. The proto-method has been used to state and help with the SoS development process, which is composed of three phases. The first phase is the definition phase where the SoS is depicted to understand the current problem. In addition, a system lexicon is created in this phase to determine the problem boundaries and to guide the second phase (abstraction).

Model stakeholders and their interactions are identified in the abstraction phase and the conceptual model is created, which leads to the third phase (implementation), wherein the conceptual model is converted into actual computer simulation using the proper development environment in addition to simulation validation and verification as shown in Figure 4.5 below.

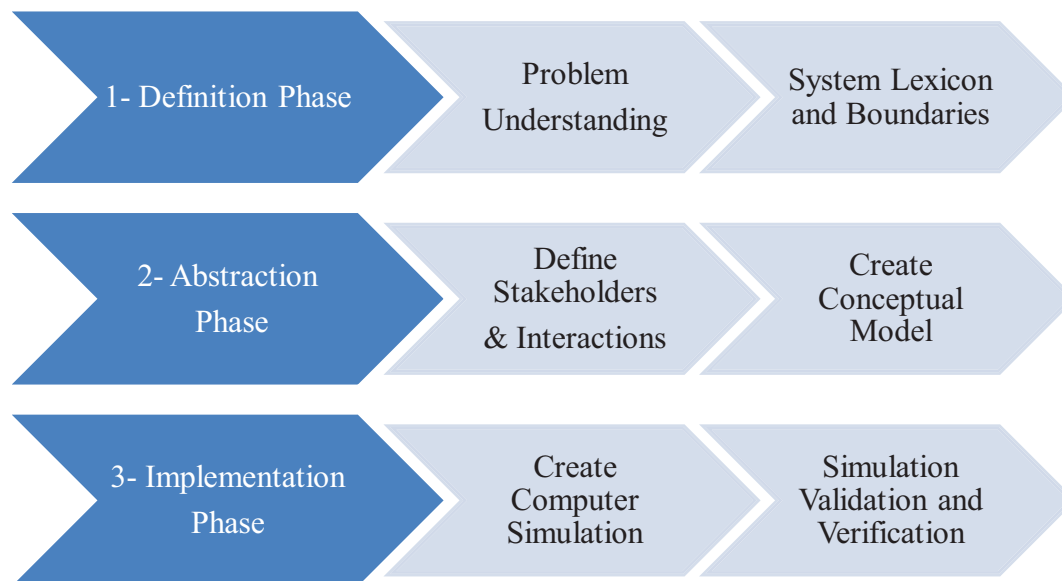

Figure 4.5 Proto-method Methodology

4.4.1 Tactical Level ABM Definition Phase:

In the definition phase, the problem is clarified and analyzed. As mentioned in the introduction, the main problem addressed by this research is the lack of a proper holistic decision support tool that can help school decision-makers gain a more comprehensive understanding of the current situation in order to make better managerial decisions. For the tactical level (TL-ABS) model, the HVAC system was selected to demonstrate the complex and mutual effect of the school facilities on the whole system. In that context, the current problem we are trying to overcome is providing a better indoor learning environment for children by only utilizing the available limited resources.

The cause and effect diagram shown in Figure 4.6 is used to analyze the possible causes for poor indoor thermal and air quality in the classroom environment. Cause and effect diagrams (also called fishbone or Ishikawa diagrams) were proposed by Kaoru Ishikawa to identify possible causes of an effect or problem (Pamoukov, 2011).

This cause and effect diagram is based on our literature review and discussions with HVAC engineers and school building operators. The potential causes were categorized into four major groups: environment, people, HVAC system, and management and policies.

1- Environment: The environment factor can be further divided into two sub-factors: weather and classroom. As discussed earlier, outdoor temperature and pollutants can greatly affect the indoor thermal and air quality in the classroom. Similarly, a classroom's lighting, furniture, equipment, and windows also can affect the IEQ of the classroom.

2- People: This factor can be divided into HVAC maintenance staff and classroom users (teachers and students).

The availability, skills, and experience of the maintenance team can greatly affect a HVAC system's performance and reliability, which in turn can affect a classroom's IEQ. On the other hand, the health of teachers and students also can affect a classroom's IAQ as germs can be passed from one person to another in poorly ventilated classrooms. Moreover, thermostat misuse or deliberate vandalism also can affect HVAC performance and in turn classroom IEQ. In addition, higher student density and higher activity levels can elevate classroom indoor temperature and worsen IAQ as well.

3- HVAC system: The third major factor is the HVAC system itself, which can be divided into the HVAC system specifications and the HVAC system status. The HVAC system specifications include the system efficiency, its useful service life as indicated by the manufacturer, and its suitability for local weather conditions and the required cooling/heating loads, which are essential for providing the best possible indoor classroom environment. On the other hand, a HVAC system's age, maintenance and failure history, and current condition also can affect its performance and consequently affect the classroom's IEQ.

4- Management and policies: This factor is divided into maintenance management policies and funding policies.

Maintenance management policies include the maintenance priority setting policies, the amount of deferred maintenance, and the level of preventive maintenance. The available funding for maintenance is important to empower maintenance management policies and decision-making.

Cause-And-Effect Diagram (Fishbone/ Ishikawa)

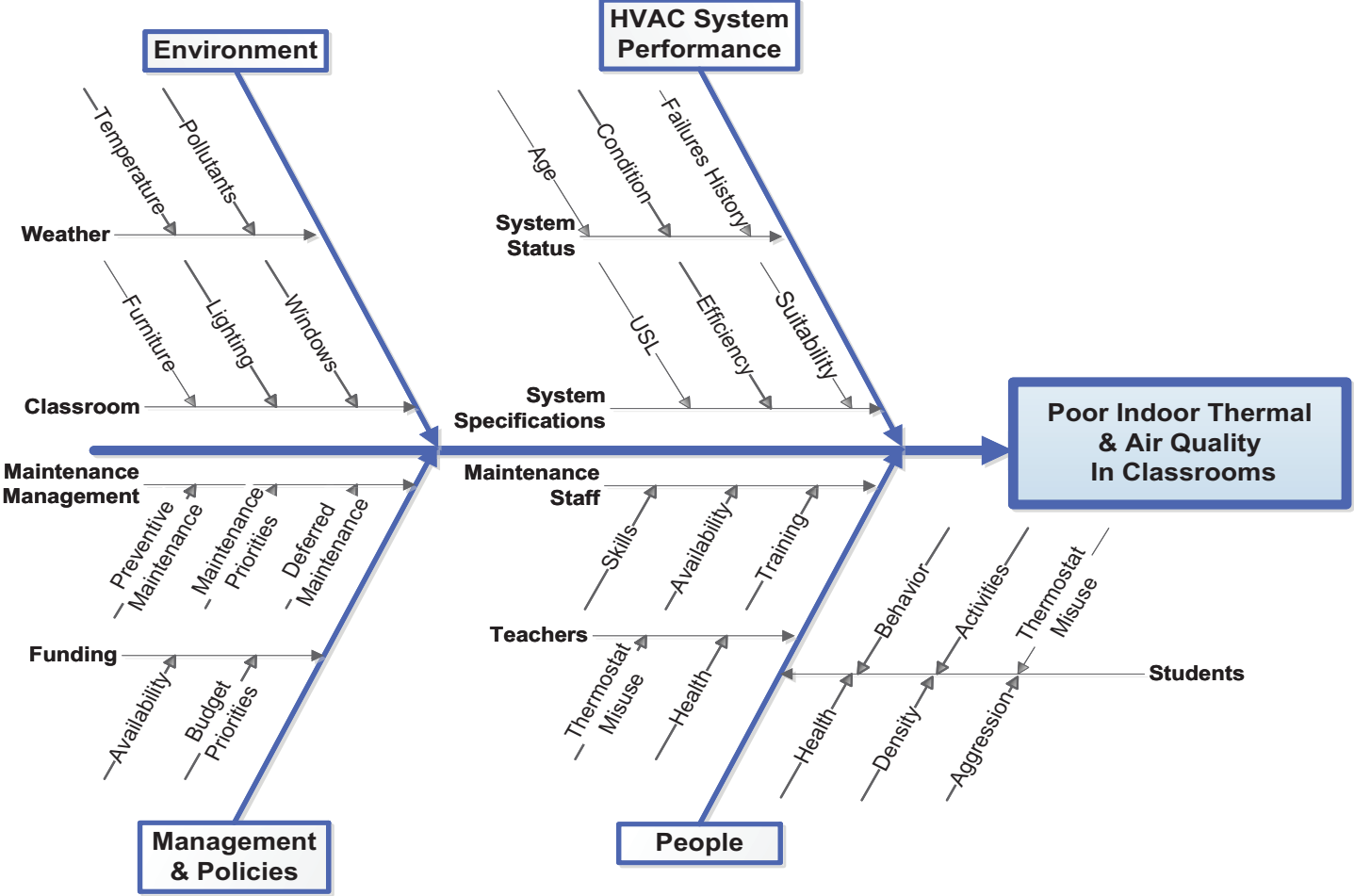

Figure 4.6 Cause and Effect Diagram Analyzing Causes for Poor Indoor Thermal and Air Quality in the Classroom Environment

The proposed tactical ABM is involved in the alpha (base level) and beta levels as shown in Table 4.13.

The model aims to capture the complex alpha level relationships inside the classroom and between the students caused by the IEQ and how it will affect the beta level school administration and facility management (FM) department and vice versa.

Table 4.13 Tactical-Level Model Lexicon and Scope (Alpha and Beta Levels)

	Resources	Operators	Economics	Policies
α (Base level)	Classrooms, HVAC subsystems & components	Maintenance technicians, teachers, students	Economics of building/operating/maintaining/buying/selling/of a single component	Teachers and students' procedures and rules, inspection requirements, maintenance technician rules
β	Single School, School HVAC System as a whole	Student body, teacher body, school admin, FM department	School payroll Economics of building/operating/maintaining/buying/selling/of a single school	Policies relating to single school
γ	Group of Schools under the same school district. (facilities)	School district superintendent	Economics of building/operating/maintaining/buying/selling/of a group of district schools	Policies relating to district schools. EPA regulations, health regulations
δ	Group of Schools in the same state. (facilities)	State Board of Education	Economics of building/operating/maintaining/buying/selling/of a group of state schools	Policies relating to State schools
ϵ	Group of Schools in USA. (facilities)	U.S. Department of Education	Economics of building/operating/maintaining/buying/selling/of a group of USA schools	Policies relating to U.S. schools

4.4.2 Tactical Level ABM Abstraction Phase:

The following two sections will discuss the tactical level conceptual model and will identify the main stakeholders and interrelations.

4.4.2.1 Tactical Level Conceptual Model (Paper Model)

The conceptual model of the proposed tactical level agent-based simulation is shown in Figure 4.7. The model consists of seven stakeholders: HVAC system, facility management/maintenance department, school administration, classroom, teachers, student, and parents.

As mentioned previously, the HVAC system was chosen in this research to demonstrate the direct and indirect two-way relationship between school facilities and students. The main purposes of the HVAC system are to provide thermal control and maintain good IAQ through filtered air ventilation. The facility management department (FMD) operates, monitors, and maintains the HVAC system in good condition to ensure the health and comfort of the school occupants and to reach or even exceed the expected service life for the HVAC system. The FMD also provides school administration with possible maintenance strategies and corresponding estimated costs and effects, but school administration has the power to decide how to spend the school's general operating budget between maintenance and instruction-related expenses. The classroom is the fourth agent in our proposed model. Classrooms should provide an optimal IEQ to help students and teachers to perform at their best. Students and teachers are the users of the classrooms and their health and performance therefore are affected by the classroom IEQ. Poor IEQ can result in a higher complaint rate and an increase in misuse and vandalism. Parents can pressure school administrators to spend more money on enhancing the school's infrastructure and maintaining its HVAC systems in good working condition; but in return, that focus can affect instruction quality and increase teachers' complaint level. The following section describes each agent in more detail.

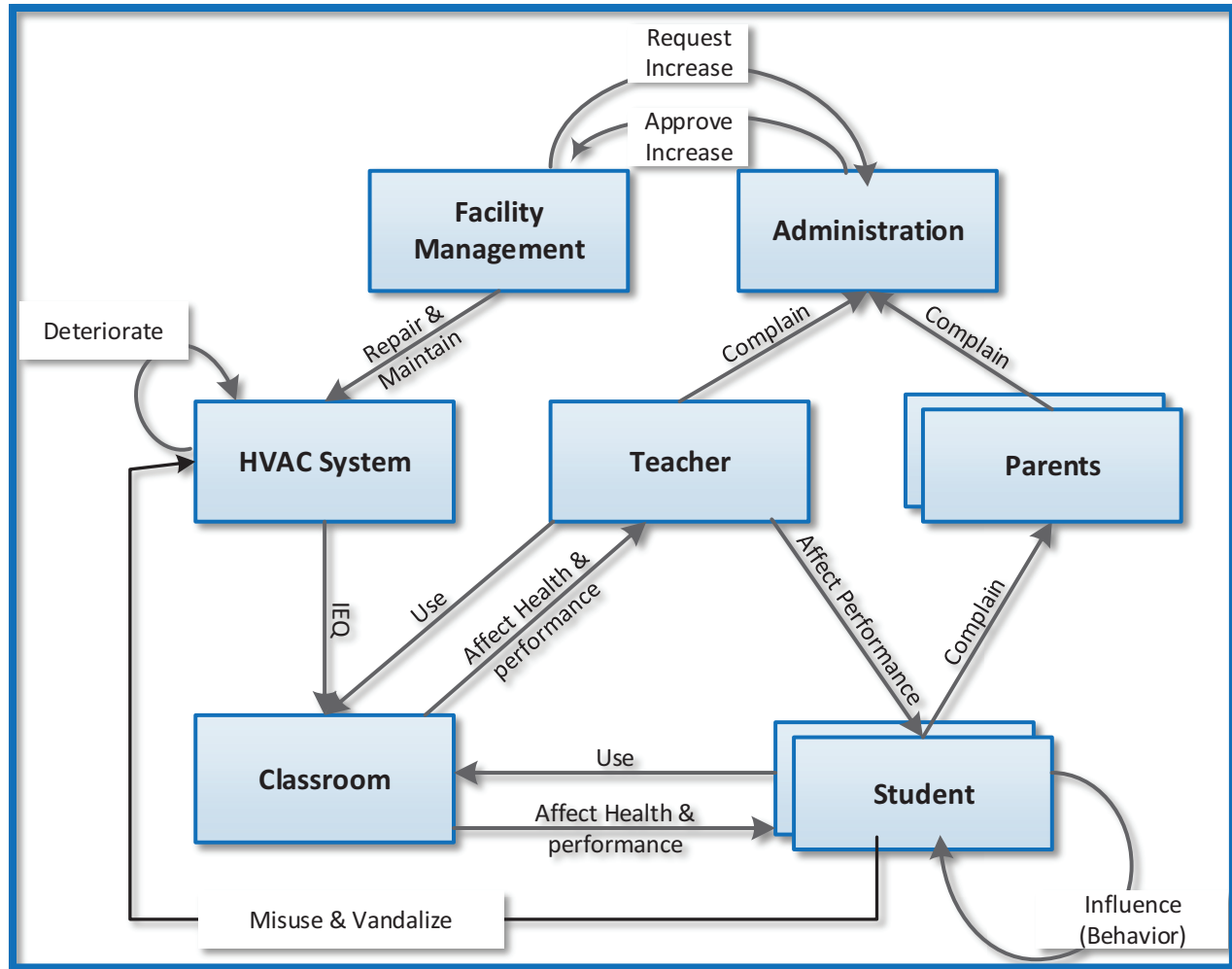

Figure 4.7 Tactical Level Conceptual Model

4.4.2.2 Tactical Level Stakeholders

The proposed model consists of seven different stakeholders (agents): students, HVAC system, classroom, facility management department, school administration, teachers, and parents. The agents' attributes and interactions are shown in Figure 4.8 for the model stakeholders, and the agents' characteristics and additional details are presented in this section.

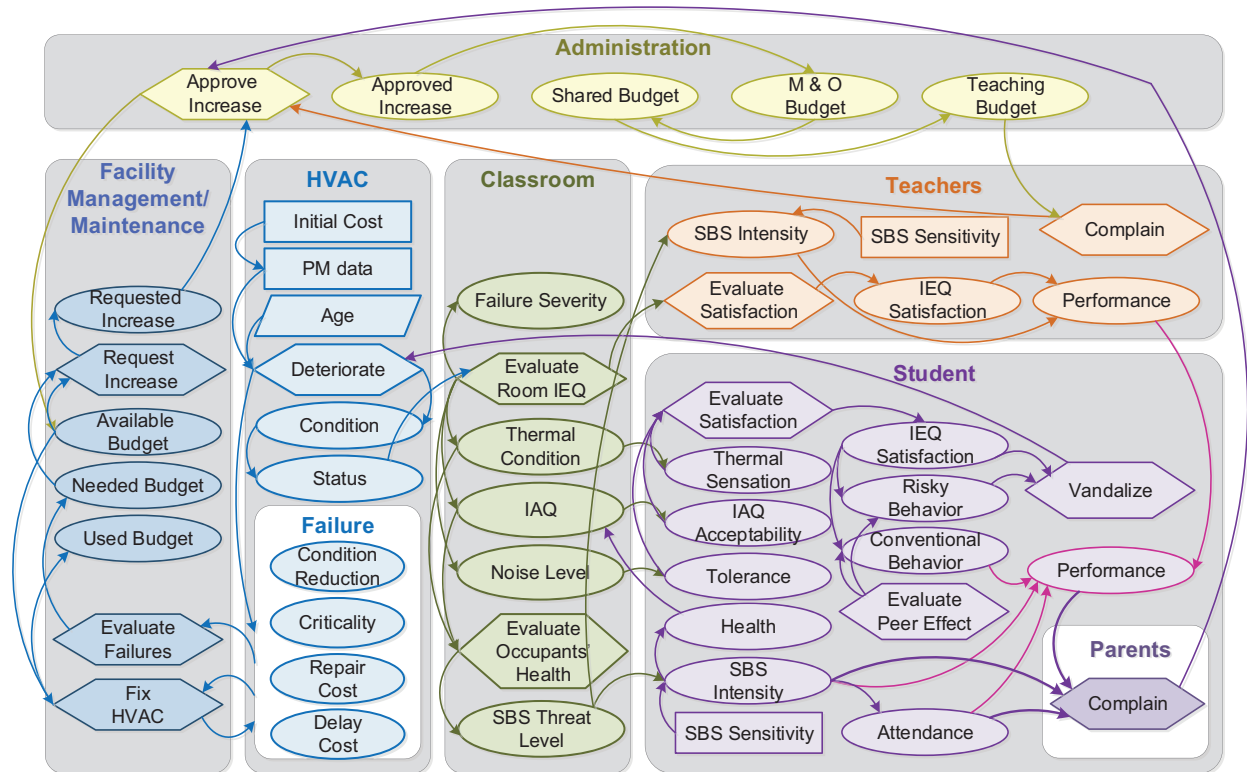

Figure 4.8 Agents' Attributes and Interactions in The Tactical Level Model

HVAC System:

The main purpose of the HVAC system is to provide healthy and comfortable IEQ through thermal control and ventilation. Like any other system, the condition of the HVAC system deteriorates with time due to wear and tear as well as misuse or vandalism. With proper preventive maintenance, the HVAC system can reach and even exceed its designed useful service life. Preventive maintenance programs include regularly scheduled tasks such as routine cleaning, belt adjustment, air filter replacement, lubrication, calibration, and inspection. Although preventive maintenance is critical to HVAC system performance, energy consumption, and service life, funding shortfalls can force school districts to overlook it, especially in a budget shared with salaries and educational equipment (Filardo, 2016).

The HVAC system can be divided into the following subsystems: cooling, heating, and air circulation. In the proposed model, each subsystem is further divided into smaller units called components as follows:

- Cooling generating subsystem: chillers, cooling towers, and pumps.
- Heat generating subsystem: boilers and pumps.
- Air circulation subsystem: Fan-coil unit (FCU) will be used for air ventilation and circulation, which is composed of fans, coils, filters, and thermostats.

The first two subsystem affect the whole school while the fan-coil units (FCUs) affect the classroom where they are installed.

As shown in Figure 4.9, the HVAC system components (chiller, pump, fan, filter, etc.) have static attributes such as type, USL, initial cost, preventive maintenance data, and deterioration rate. The components also have time-dependent attributes, such as age, which increase with every simulation step. The condition index (CI) and status are two important attributes that can significantly affect the simulation behavior. Both are used for evaluating HVAC system performance. They can change with time or due to certain actions and therefore are considered both time and action-dependent attributes.

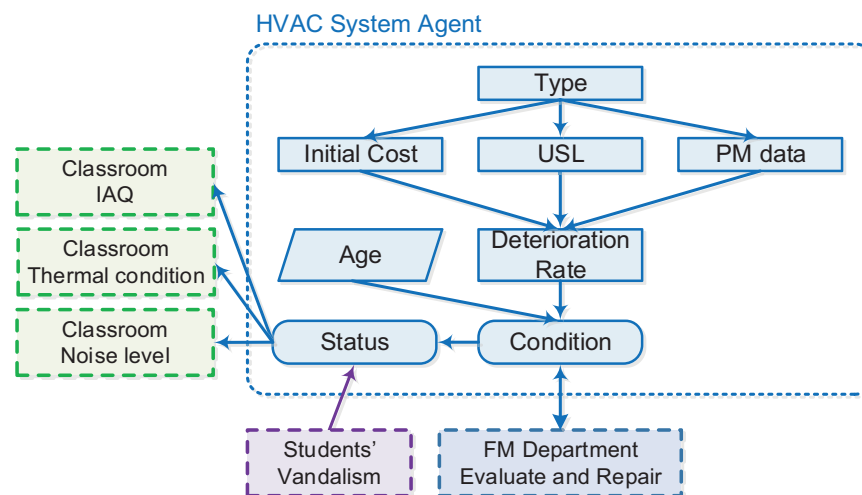

Figure 4.9 HVAC System Agent Attributes and Interactions

Student Agent:

The student agent is the core of our simulation. Students reside inside the classroom agent and are affected by the classroom IEQ. Good IEQ can improve students' health, behavior, and performance while bad IEQ can negatively impact student health and behavior, which in turn can lower students' performance and increase the chances for vandalism and complaints. The student agent's main attributes are shown in Figure 4.10 and can be categorized as follows:

- 1- Students' demographic information: gender, race, and socio-economic status (SES) information, which will be used for social network formation.
- 2- Students' behaviors: conventional and risky behaviors. Conventional behavior has a positive effect on performance, such as going to school, studying, doing homework, and participating in sports while risky behavior has a negative effect on students' performance, such as aggression, vandalism, missing classes, and using alcohol/drugs. In the proposed model, the behaviors can be modified by peer effect or by IEQ satisfaction through the "Human Agent's Perception Evaluation Model," which will be explained later in the implementation phase section.
- 3- Student health and SBS intensity. At the beginning of the simulation, each student is assigned a SBS sensitivity value. Depending on the SBS sensitivity value, each student/occupant will react differently to the classroom SBS threat level, resulting in a different SBS intensity value for each student. Higher SBS intensity values will affect a student's health overall and may cause the student to be hospitalized and unable to attend school.
- 4- Student IEQ interaction and satisfaction attributes: thermal sensation, IAQ acceptability, tolerance, and IEQ overall satisfaction. The first three attributes are directly related to the classroom thermal condition, the IAQ, and the noise level, respectively, and represent the input for the fuzzy logic IEQ satisfaction model that will be discussed later in the implementation phase section.
- 5- Student performance: Performance is affected by changes in the conventional and risky behaviors values in addition to changes in the teachers' performance overall. Performance also is affected by the SBS intensity and attendance level as shown in Figure 4.10.

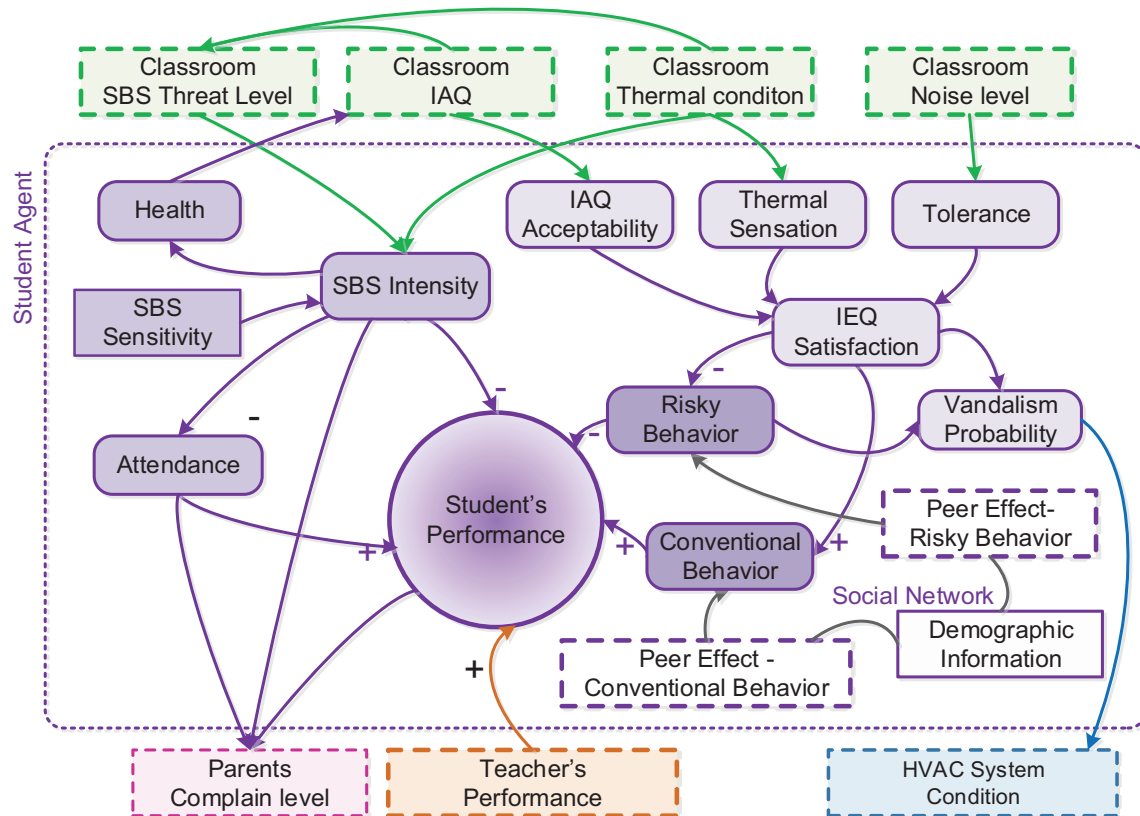

Figure 4.10 Student Agent Attributes and Interactions

Teacher Agent

The teacher agent represents the overall behavior of all the teachers who occupy a single classroom per school day. Classroom IEQ can greatly affect a teacher's health and performance and in turn negatively affect their students' performance. Although teachers are also affected by classroom IEQ, the effect on them can be limited to the time they spend in each classroom, and therefore may only affect their immediate performance teaching certain classes in each classroom. On the other hand, reducing the teaching budget for the sake of maintenance can affect teachers more than poor IEQ and will result in a higher complaint rate in that realm.

As shown in Figure 4.11, the teacher agent's main attributes are the overall IEQ satisfaction, the overall performance, the overall SBS intensity once the health of teachers is affected by SBS symptoms, and the complaint rate resulting from instructional budget cuts.

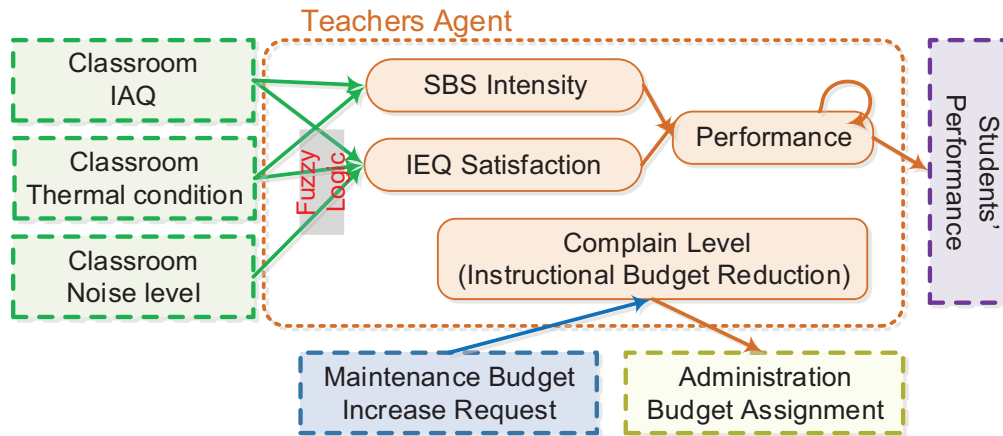

Figure 4.11 Teacher Agent Attributes and Interactions

Classroom Agent

A classroom's main purpose is to provide a safe, healthy, and comfortable environment for students and teachers to help them reach their best performance. The IEQ of the classroom is greatly affected by the HVAC system. In our model, IEQ is composed of three measures: thermal condition, IAQ, and noise level. The classroom attributes can be categorized as follows:

- 1- IEQ Attributes. In the proposed model, IEQ is composed of three attributes: thermal condition, IAQ, and noise level as shown in Figure 4.12.
 - a. Thermal condition is a function of the outside temperature (weather) and the HVAC system status.
 - b. The IAQ is a function of the HVAC system status as well as the classroom overall average health affected by allergies and flu seasons.
 - c. Noise level caused by poor performance by the HVAC system.
- 2- The SBS threat level is an indication of the quality of the classroom's indoor air and is mainly a function of the classroom's IAQ, which a higher thermal condition may make worse.
- 3- The IEQ severity is a single number that describes the severity of the IEQ condition.

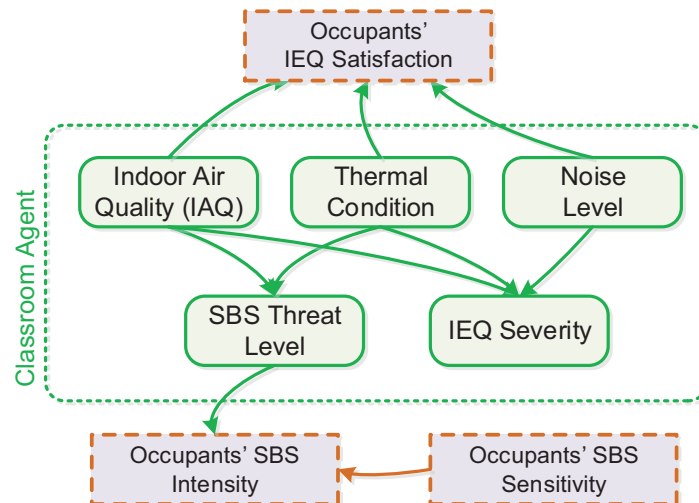

Figure 4.12 Classroom Agent Attributes and Interactions

Facility Management Department (FMD) Agent

The facility management department (FMD) is responsible for operating and maintaining the HVAC system. In addition to attending to occupants' complaints regarding the indoor environmental quality in the classroom. The FMD prepares an operating and maintenance plan and recommends maintenance strategies with their cost estimations to school administration to select the best suitable strategy to meet the school's goals within the available funding. As shown in Figure 4.13, the FMD agent attributes include:

- A list of the HVAC component's failures. Each failure has several attributes of its own such as the following:
 - The HVAC component to which it belongs.
 - The condition reduction it causes to the component's CI.
 - The criticality of the failure, where it can be critical, potentially critical, or not critical.
 - Repair cost, which is a function of condition reduction amount.
 - Deferred repair possible extra cost.
 - Failure priority: The FMD evaluates the priority of HVAC component failure using school administration selected policy and based on the failure's effect, which is a function of the affected area (whole school or single classroom), failure criticality, repair deferring cost, and the negative change in student performance.

- Needed budget: the total needed maintenance budget for repairing current failures.
- Total expenditures: the sum of all the repaired failures.
- Available budget: the funding available for repairing and maintaining HVAC system components. The available maintenance budget comes from the M & O budget assigned by school administration based on the selected maintenance policy.
- Requested budget increase: when the needed budget is less than the available budget, the FMD requests a budget increase from school administration to repair all the current failures.

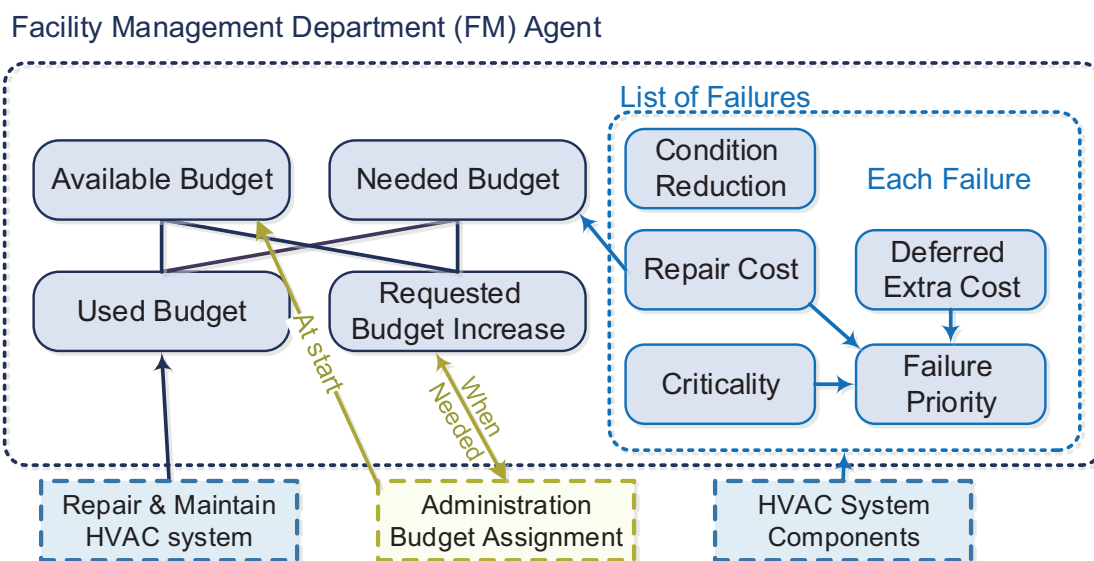

Figure 4.13 FMD Agent Attributes and Interactions

School Administration Agent

The school administration manages the budget for both O & M and educational expenses. Higher parent complaint levels can pressure school administration to increase maintenance funding. However, the O & M budget is shared with the instructional expenses budget so spending more money on maintenance will result in reducing the funding for teaching and thereby can cause a higher level of teacher complaints.

As shown in Figure 4.14, the school administration attributes are mostly related to funding and includes: the shared budget, the O&M budget, the instructional budget, and the approved O&M budget increase. The agent has one method (approve O&M budget increase), which includes evaluating both the teacher and parent complaints and decide how to spend the available budget.

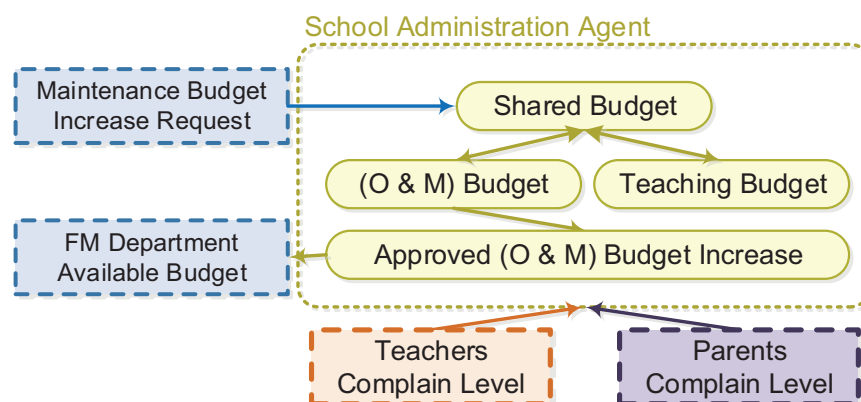

Figure 4.14 School Administration Agent Attributes and Interactions

Parents Agent

Negative changes in student performance, SBS intensity, and attendance problems can trigger parent complaints. As shown in Figure 4.15, parents can complain to school administrators to increase the maintenance budget in order to repair the HVAC system to improve classroom IEQ and in turn improve their children's health and performance.

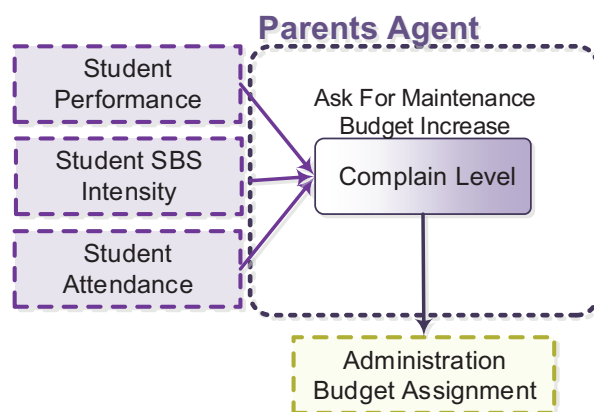

Figure 4.15 Parents Agent Attributes and Interactions

4.4.3 Implementation Phase

The general and HVAC UML class diagrams for the model implementation is shown in Figures 4.16 and 4.17, the next sections will describe the simulation implementation, starting first with each agent's implementation details, then discussing the program execution process, and ending with a presentation of the case study used for testing the model along with the validation and verification process.

4.4.3.1 Agents Implementation & Dynamics

This section will discuss the implementation of the seven agents of the tactical level ABM shown in Figure 4.18.

4.4.3.1.1 Students Agent

Students Agent Initialization

During creation of the students agent, their initial health, behavior, and performance were assigned randomly to each student instance. Conventional and risky behaviors assignment followed normal distribution with: (min=0.1, max = 0.9, mean, sigma= 0.2). The classroom was divided into three groups: Conventional students with mean values of 0.7 for conventional behavior and 0.3 for risky behavior; risky students with mean values of 0.3 for conventional behavior and 0.7 for risky behavior; and semi-risky-semi-conventional students with mean values of 0.5 for both conventional and risky behaviors. Their initial health and performance were also assigned randomly during agent creation in the simulation startup. Initial health assignment followed normal distribution: (min= 0.4, max=1, mean=0.85, sigma= 0.05). During simulation, the students' health was affected by their SBS intensity level, which is the result of the student's SBS sensitivity assigned randomly at simulation initialization and the classroom's SBS threat level.

Performance assignment initially followed normal distribution (min= 0.3, max=1, mean=0.7, sigma= 0.1), but then was modified with respect to conventional behavior. During simulation, student performance was affected by attendance, SBS intensity, conventional behavior, risky behavior, and teacher performance as shown in Figure 4.18. The performance value was dependent on the previous (t-1) performance value and therefore was affected by the change in conventional and risky behaviors values in addition to the change in the overall teacher performance.

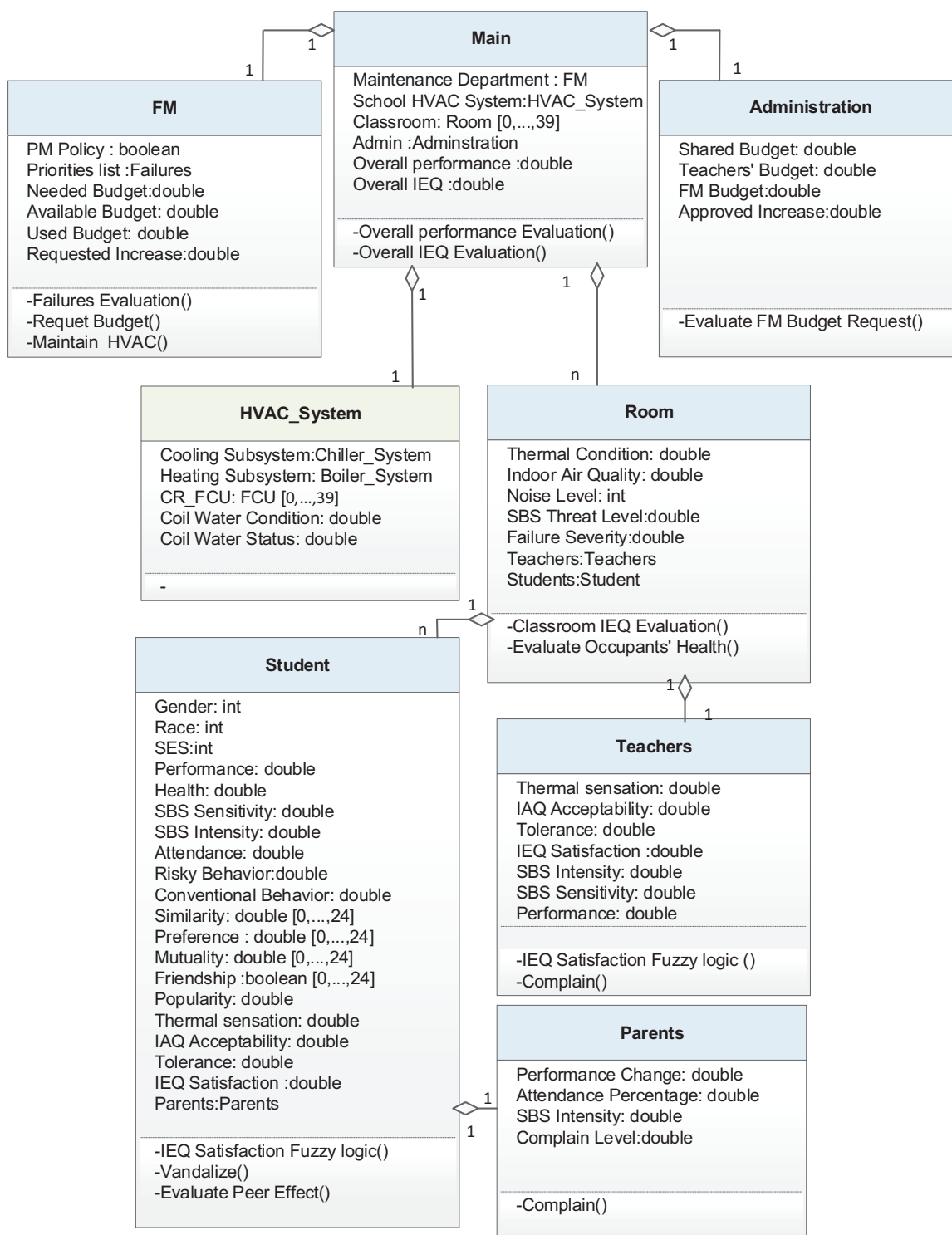

Figure 4.16 General UML Class Diagram

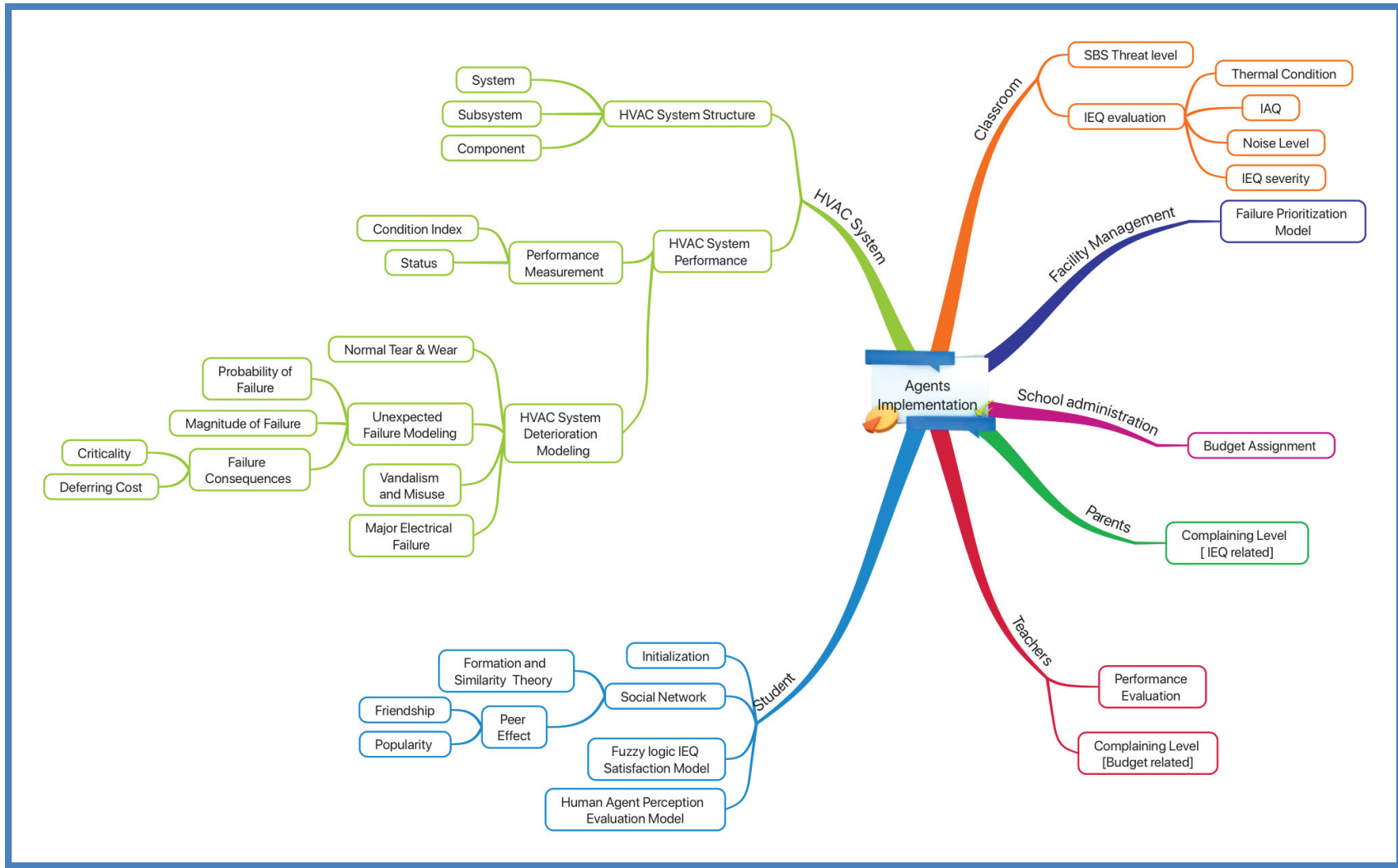

Figure 4.18 Agents Implementation Section Mind Map

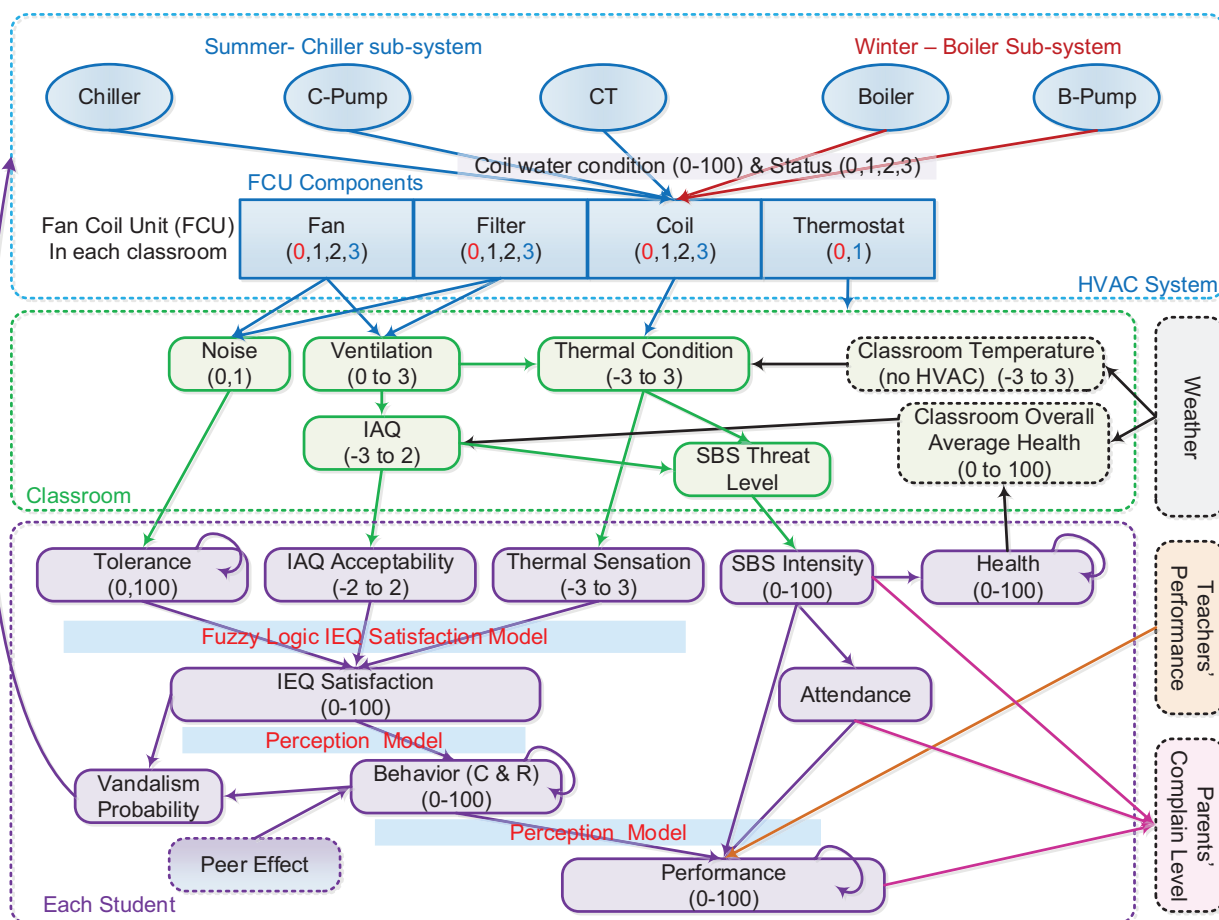
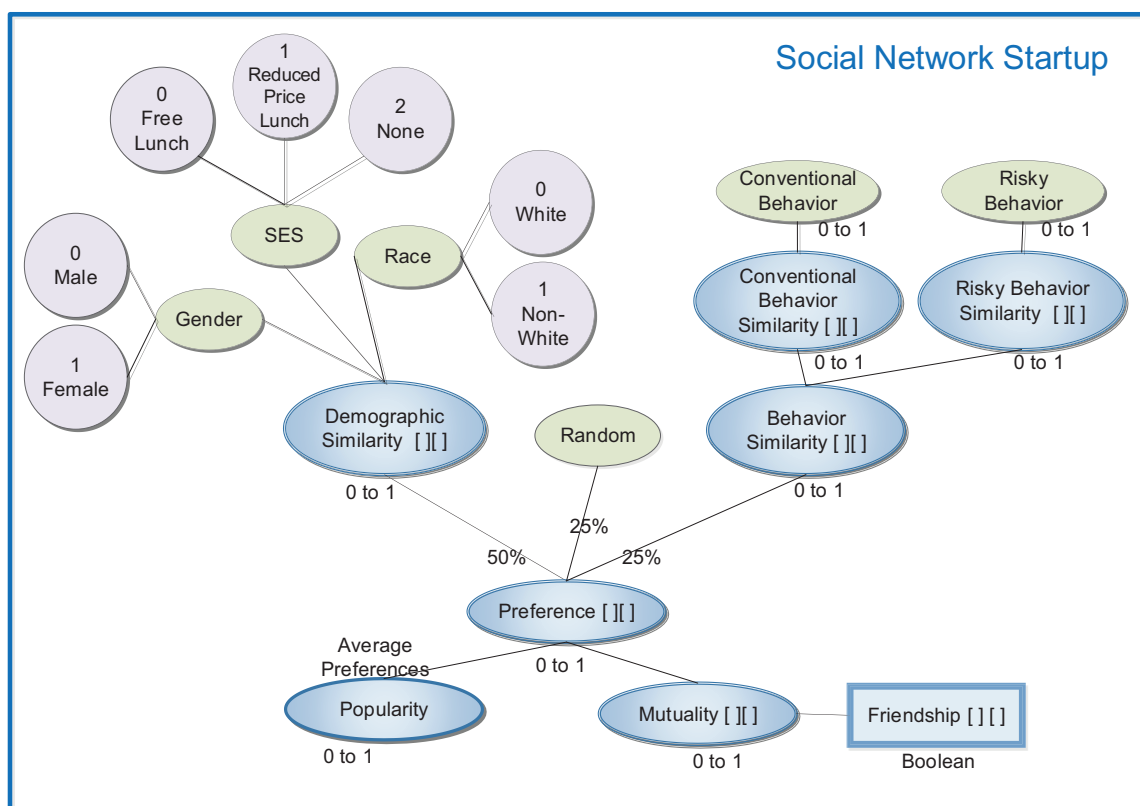

Figure 4.19 HVAC System, Classroom, and Student Agents' Interactions

Students' Social Network Formation and Effect

According to similarity model theory, students tend to become friends with other students like them (e.g., similar in demographic status and behavioral characteristics) (Ballato, 2012). To represent the social network and peer effect, our model utilized a simplified version of the conceptual model developed by Ballato (2012) and modified by Schuhmacher et al. (2014). At the beginning of the simulation (Figure 4.20a), the students agent evaluated the behavioral and demographic similarity with every other student in the classroom. Based on the evaluation results, the student agent assessed their preferences toward other students in the classroom and friendships formed when two agents had high mutual preference values toward each other.

This peer effect can be a result of friendship or popularity, which is the average of all the preference values toward one student. Based on the mutuality and popularity values, student agents can interact with each other and some interactions can affect the behavior of both students as show in Figure 4.20b. During simulation, a student's IEQ satisfaction and interaction with other students changed both their conventional and risky behaviors. As a result, their similarity, preference, popularity, mutuality, and friendship relations were reevaluated.



a) Students' Social Network Initialization.

Figure 4.20 Students' Social Network

(Modified Version of the Model Developed by Ballato (2012) and Schuhmacher et al. (2014))

Figure 4.20 Continued

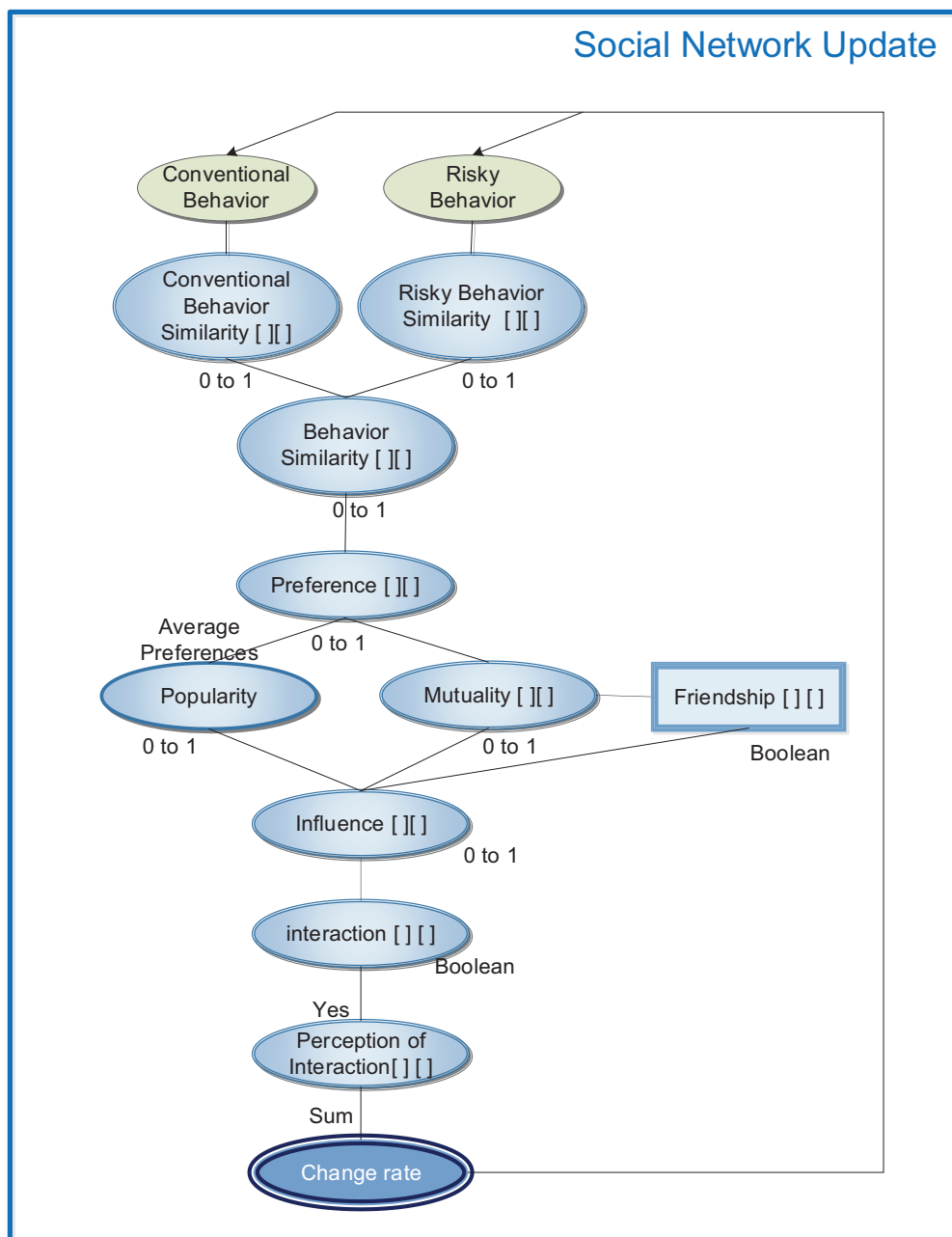

b) Students' Social Network Update Cycle

Fuzzy Logic IEQ Satisfaction Model:

IEQ satisfaction was evaluated using fuzzy logic. The fuzzy logic concept was first introduced by Prof. Lotfi A. Zadeh in the mid-1960s (Zadeh, 1965). Fuzzy logic can be defined as “the nonlinear mapping of an input data set to a scalar output data” (Mendel,1995). A fuzzy logic system (FLS) starts with the construction of membership functions to convert crisp inputs and outputs into fuzzy values and vice versa, then the rules to be applied to the inputs to get the output are defined. (Mendel, 1995; Ponce-Cruz & Ramírez-Figueroa, 2009).

Our fuzzy logic IEQ satisfaction model was evaluated over two levels/steps. The first level evaluated the IEQ satisfaction with respect to students’ thermal sensation, which ranged between -3 (cold) to 3 (hot) and indoor air quality acceptability that ranged between -2 (extremely unacceptable) to 2 (extremely acceptable) as shown in Figures 4.21 a, b, & c. Then, the resulted value was modified with respect to a student’s tolerance, which was affected by the classroom noise level using the second level fuzzy logic system as shown in Figures 4.22 a, b, & c. The same fuzzy logic model was used to evaluate teacher IEQ satisfaction.

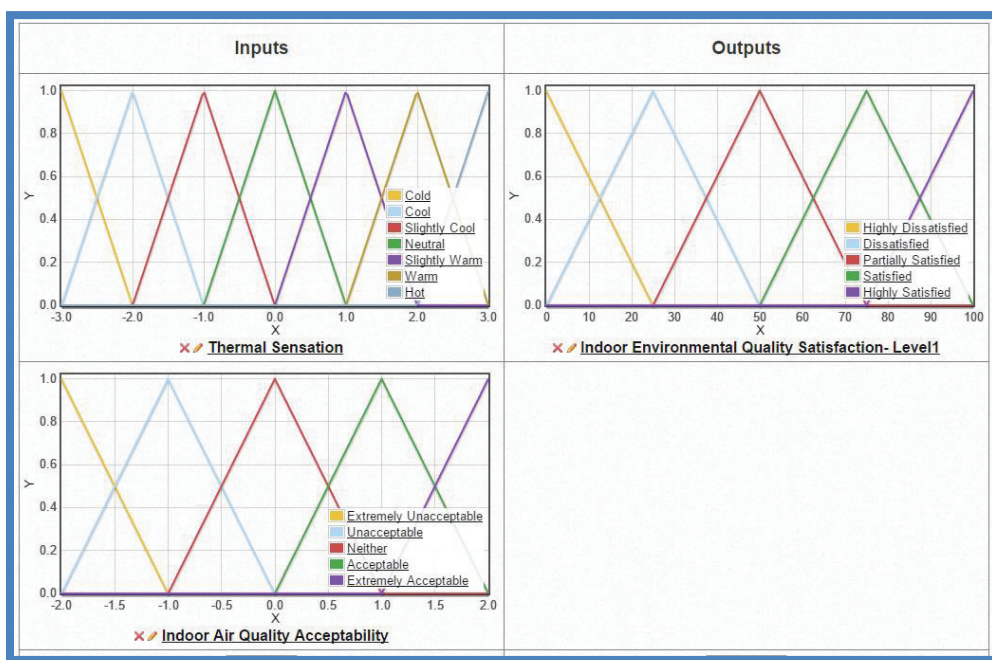

a) level 1 Membership Functions

Figure 4.21 Level 1 of IEQ Satisfaction Fuzzy Logic

Figure 4.21 Continued

Fuzzy Logic Rules- Level1 Indoor Environmental Quality (IEQ) Satisfaction			Indoor Air Quality (IAQ)				
			Extremely Unacceptable	Unacceptable	Neither	Acceptable	Extremely Acceptable
			-2	-1	0	1	2
Thermal Sensation	Cold	-3	Highly Dissatisfied	Highly Dissatisfied	Highly Dissatisfied	Dissatisfied	Dissatisfied
	Cool	-2	Highly Dissatisfied	Highly Dissatisfied	Dissatisfied	Partially Satisfied	Partially Satisfied
	Slightly Cool	-1	Highly Dissatisfied	Dissatisfied	Partially Satisfied	Satisfied	Satisfied
	Neutral	0	Dissatisfied	Partially Satisfied	Satisfied	Satisfied	Highly Satisfied
	Slightly Warm	1	Highly Dissatisfied	Dissatisfied	Partially Satisfied	Satisfied	Satisfied
	Warm	2	Highly Dissatisfied	Highly Dissatisfied	Dissatisfied	Partially Satisfied	Partially Satisfied
	Hot	3	Highly Dissatisfied	Highly Dissatisfied	Highly Dissatisfied	Dissatisfied	Dissatisfied

b) Level 1 Rules Matrix

```

RULE 1 : IF thermal_sensation IS cold AND iaq_acceptability IS ex_unacceptable THEN ieq_satisfaction IS h_dissatisfied;
RULE 2 : IF thermal_sensation IS cold AND iaq_acceptability IS unacceptable THEN ieq_satisfaction IS h_dissatisfied;
RULE 3 : IF thermal_sensation IS cold AND iaq_acceptability IS neither THEN ieq_satisfaction IS h_dissatisfied;
RULE 4 : IF thermal_sensation IS cool AND iaq_acceptability IS ex_unacceptable THEN ieq_satisfaction IS h_dissatisfied;
RULE 5 : IF thermal_sensation IS cool AND iaq_acceptability IS unacceptable THEN ieq_satisfaction IS h_dissatisfied;
RULE 6 : IF thermal_sensation IS slightly_cool AND iaq_acceptability IS ex_unacceptable THEN ieq_satisfaction IS h_dissatisfied;

RULE 7 : IF thermal_sensation IS hot AND iaq_acceptability IS ex_unacceptable THEN ieq_satisfaction IS h_dissatisfied;
RULE 8 : IF thermal_sensation IS hot AND iaq_acceptability IS unacceptable THEN ieq_satisfaction IS h_dissatisfied;
RULE 9 : IF thermal_sensation IS hot AND iaq_acceptability IS neither THEN ieq_satisfaction IS h_dissatisfied;
RULE 10 : IF thermal_sensation IS warm AND iaq_acceptability IS ex_unacceptable THEN ieq_satisfaction IS h_dissatisfied;
RULE 11 : IF thermal_sensation IS warm AND iaq_acceptability IS unacceptable THEN ieq_satisfaction IS h_dissatisfied;
RULE 12 : IF thermal_sensation IS slightly_warm AND iaq_acceptability IS ex_unacceptable THEN ieq_satisfaction IS h_dissatisfied;

RULE 13 : IF thermal_sensation IS neutral AND iaq_acceptability IS ex_unacceptable THEN ieq_satisfaction IS dissatisfied;
RULE 14 : IF thermal_sensation IS slightly_warm AND iaq_acceptability IS unacceptable THEN ieq_satisfaction IS dissatisfied;
RULE 15 : IF thermal_sensation IS slightly_cool AND iaq_acceptability IS unacceptable THEN ieq_satisfaction IS dissatisfied;

RULE 16 : IF thermal_sensation IS cool AND iaq_acceptability IS neither THEN ieq_satisfaction IS dissatisfied;
RULE 17 : IF thermal_sensation IS warm AND iaq_acceptability IS neither THEN ieq_satisfaction IS dissatisfied;

RULE 18 : IF thermal_sensation IS cold AND iaq_acceptability IS acceptable THEN ieq_satisfaction IS dissatisfied;
RULE 19 : IF thermal_sensation IS cold AND iaq_acceptability IS ex_acceptable THEN ieq_satisfaction IS dissatisfied;
RULE 20 : IF thermal_sensation IS hot AND iaq_acceptability IS acceptable THEN ieq_satisfaction IS dissatisfied;
RULE 21 : IF thermal_sensation IS hot AND iaq_acceptability IS ex_acceptable THEN ieq_satisfaction IS dissatisfied;

RULE 22 : IF thermal_sensation IS neutral AND iaq_acceptability IS unacceptable THEN ieq_satisfaction IS P_satisfied ;
RULE 23 : IF thermal_sensation IS slightly_warm AND iaq_acceptability IS neither THEN ieq_satisfaction IS P_satisfied;
RULE 24 : IF thermal_sensation IS slightly_cool AND iaq_acceptability IS neither THEN ieq_satisfaction IS P_satisfied;
RULE 25 : IF thermal_sensation IS cool AND iaq_acceptability IS acceptable THEN ieq_satisfaction IS P_satisfied ;
RULE 26 : IF thermal_sensation IS warm AND iaq_acceptability IS acceptable THEN ieq_satisfaction IS P_satisfied ;
RULE 27 : IF thermal_sensation IS cool AND iaq_acceptability IS ex_acceptable THEN ieq_satisfaction IS P_satisfied ;
RULE 28 : IF thermal_sensation IS warm AND iaq_acceptability IS ex_acceptable THEN ieq_satisfaction IS P_satisfied ;

RULE 29 : IF thermal_sensation IS neutral AND iaq_acceptability IS neither THEN ieq_satisfaction IS satisfied ;

RULE 30 : IF thermal_sensation IS slightly_warm AND iaq_acceptability IS acceptable THEN ieq_satisfaction IS satisfied;
RULE 31 : IF thermal_sensation IS slightly_cool AND iaq_acceptability IS acceptable THEN ieq_satisfaction IS satisfied;
RULE 32 : IF thermal_sensation IS neutral AND iaq_acceptability IS acceptable THEN ieq_satisfaction IS satisfied ;

RULE 33 : IF thermal_sensation IS slightly_warm AND iaq_acceptability IS ex_acceptable THEN ieq_satisfaction IS satisfied;
RULE 34 : IF thermal_sensation IS slightly_cool AND iaq_acceptability IS ex_acceptable THEN ieq_satisfaction IS satisfied;
RULE 35 : IF thermal_sensation IS neutral AND iaq_acceptability IS ex_acceptable THEN ieq_satisfaction IS h_satisfied ;

```

c) Level 1 Rules

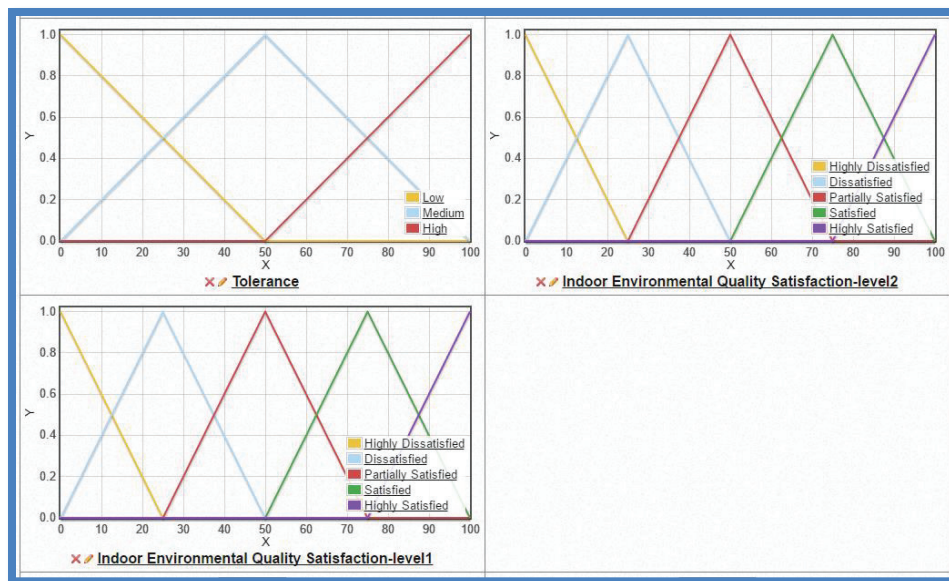

a) Level 2 Membership Functions.

Fuzzy Logic Rules- Level2			Indoor Environmental Quality (IEQ) Satisfaction -Level1				
Indoor Environmental Quality (IEQ) Satisfaction			Highly Dissatisfied	Dissatisfied	Partially Satisfied	Satisfied	Highly Satisfied
			-2	-1	0	1	2
Tolerance	Low	-1	Highly Dissatisfied	Highly Dissatisfied	Dissatisfied	Partially Satisfied	Satisfied
	Medium	0	Highly Dissatisfied	Dissatisfied	Partially Satisfied	Satisfied	Highly Satisfied
	High	1	Dissatisfied	Partially Satisfied	Satisfied	Highly Satisfied	Highly Satisfied

b) Level 2 Rules Matrix.

```

RULEBLOCK No1
AND : MIN;           // Use 'min' for 'and' (also implicit use 'max' for 'or' to fulfill DeMorgan's Law)
ACT : MIN;           // Use 'min' activation method
ACCU : MAX;          // Use 'max' accumulation method

RULE 1 : IF tolerance IS low AND ieq_satisfaction_l1 IS h_dissatisfied THEN ieq_satisfaction_l2 IS h_dissatisfied;
RULE 2 : IF tolerance IS low AND ieq_satisfaction_l1 IS dissatisfied THEN ieq_satisfaction_l2 IS h_dissatisfied;
RULE 3 : IF tolerance IS med AND ieq_satisfaction_l1 IS h_dissatisfied THEN ieq_satisfaction_l2 IS h_dissatisfied;

RULE 4 : IF tolerance IS low AND ieq_satisfaction_l1 IS P_satisfied THEN ieq_satisfaction_l2 IS dissatisfied ;
RULE 5 : IF tolerance IS med AND ieq_satisfaction_l1 IS dissatisfied THEN ieq_satisfaction_l2 IS dissatisfied ;
RULE 6 : IF tolerance IS high AND ieq_satisfaction_l1 IS h_dissatisfied THEN ieq_satisfaction_l2 IS dissatisfied ;

RULE 7 : IF tolerance IS low AND ieq_satisfaction_l1 IS satisfied THEN ieq_satisfaction_l2 IS P_satisfied ;
RULE 8 : IF tolerance IS med AND ieq_satisfaction_l1 IS P_satisfied THEN ieq_satisfaction_l2 IS P_satisfied ;
RULE 9 : IF tolerance IS high AND ieq_satisfaction_l1 IS dissatisfied THEN ieq_satisfaction_l2 IS P_satisfied ;

RULE 10 : IF tolerance IS low AND ieq_satisfaction_l1 IS h_satisfied THEN ieq_satisfaction_l2 IS satisfied ;
RULE 11 : IF tolerance IS med AND ieq_satisfaction_l1 IS satisfied THEN ieq_satisfaction_l2 IS satisfied ;
RULE 12 : IF tolerance IS high AND ieq_satisfaction_l1 IS P_satisfied THEN ieq_satisfaction_l2 IS satisfied ;

RULE 13 : IF tolerance IS med AND ieq_satisfaction_l1 IS h_satisfied THEN ieq_satisfaction_l2 IS h_satisfied ;
RULE 14 : IF tolerance IS high AND ieq_satisfaction_l1 IS satisfied THEN ieq_satisfaction_l2 IS h_satisfied ;
RULE 15 : IF tolerance IS high AND ieq_satisfaction_l1 IS h_satisfied THEN ieq_satisfaction_l2 IS h_satisfied ;

END_RULEBLOCK
    
```

c) Level 2 Rules.

Figure 4.22 Level 2 of IEQ Satisfaction Fuzzy Logic

Human Agent's Perception Evaluation Model

A human agent's attributes and the way they affect each other has a unique nature in agent-based modeling. In our model, there were classrooms with 25 students each. At the beginning of the simulation, each student was assigned a random initial performance and conventional and risky behavior values ranging from 0 to 1. During simulation, each student's IEQ satisfaction resulted from the fuzzy logic model were affected by both conventional and risky behaviors. Although a higher satisfaction level generally has a positive effect on conventional behavior and a negative effect on risky behavior, when dealing with human nature, we found that previous experience can have a great effect on expectations which in turn can affect human perceptions and actions. For more clarification, Table 4.14 shows different scenarios that can help in understanding the effect of previous values on human perception. The high satisfaction level ($S=0.8$) in the first and second scenarios was perceived differently when previous satisfaction level values were taken into consideration. Although the IEQ satisfaction was relatively high ($S=0.8$) in the first case, the student felt that the IEQ got worse since the previous time step where their satisfaction was ($S=0.95$). In the second case, the student felt that the IEQ was good because it improved for them since the previous time step ($S=0.65$). Similarly, scenarios 3 and 4 had the same low satisfaction value ($S=0.4$), but case 4 also perceived differently because the satisfaction improved from the previous time step.

In conclusion, both the current value (i.e., X at time t) and the change from the previous value ($\Delta X = X_t - X_{t-1}$) are important for creating more accurate human agent perception evaluation model especially for input variables that are independent from their own previous value at $(t-1)$ such as IEQ satisfaction. This conclusion was our motivation for creating a standardized approach for evaluating human agent perception.

Let's assume that we have a variable X ranging from 0 to 1. As a result, ΔX values can range between -1 and 1, where -1 indicates the maximum possible negative change (ex. Current $X=0$, Previous $X=1$), and 1 indicates the maximum possible positive change (ex. Current $X=1$, Previous $X=0$).

The proposed perception evaluation model takes the weighted average of both: the current value X and the difference between the current and previous values (ΔX). The first step was to convert X from (0 to 1) scale, to (-1 to 1) scale. This step was very important for two reasons: first, the nature of the variable where lower values have negative effect on depended variable (e.g., low satisfaction value of 0.3 has negative effect on conventional behavior) and secondly, to unify the scale between X and ΔX for accurate results (both range from -1 to 1). To add more flexibility to the model, the factor α was added to the equation to give more weight to current value or the change amount (ΔX).

$$\text{Change} = MC \times \sum_i^n [a_i * [(\alpha_i \times X'_i) + ((1 - \alpha_i) * \Delta X_i)]] , \quad \sum_i^n a_i = 1 \quad (4.1)$$

$$D_t = D_{t-1} + \text{Change}$$

Where:

Change = the possible change to dependent value D . It could be negative or positive,

D = Dependent output variable (i.e. student performance),

MC=Maximum possible change, can be evaluated in two ways:

- $MC = [k \times D_{t-1}]$, as a percentage to dependent variable D .
- MC= Fixed value, for example (0.1).

α, a_i = weight factors (range: 0 to 1),

k = weight factor (range: -1 to 1),

n = Number of input variables,

X_i = input variables (i.e. teachers performance and student behavior),

$X' = 2 X_t - 1$, to convert X_t from 0 to 1 range to -1 to 1 range,

$\Delta X = X_t - X_{t-1}$ (i.e. the change in student behavior)

The equation's result (change) can be used deterministically or stochastically as a mean value for normal distribution as shown in the equation.

The same equation can be used with any number of input variables and can be applied to input values dependent on their previous values by simply using ($\alpha = 0$). A good example for such a case is the student performance evaluation model. Student performance was dependent on the student's

previous performance and was affected by the change in behavior and the teacher's performance. which also dependent on their previous values.

Table 4.14 shows the results of the proposed perception model. In general, a high satisfaction value ($S=0.8$) should have a positive effect on conventional behavior. The proposed model quantifies this relation, taking previous satisfaction values into consideration. The model gives different values for the possible three cases: $\Delta X < 0$ (decreased satisfaction), $\Delta X = 0$ (same satisfaction), and $\Delta X > 0$ (increased satisfaction). Scenarios (1, 5, and 2) represent the three cases, and the model results were: (0.225, 0.3, and 0.375), respectively. The results show that with the same input value, the positive effect increased as ΔX increased.

Table 4.14 Perception Model Results for Different Satisfaction Values

Sc. Num.	Satisfaction Time t S_t	Satisfaction Time t-1 S_{t-1}	$\Delta S = S_t - S_{t-1}$	Perception Of IEQ	Proposed model (if)
1	0.8	0.95	- 0.15	Got worse	0.225
2	0.8	0.65	+ 0.15	Improved	0.375
3	0.4	0.55	- 0.15	Got worse	-0.175
4	0.4	0.25	+ 0.15	Improved	-0.025
5	0.8	0.8	0	No Change	0.3
6	0.4	0.4	0	No Change	-0.1

4.4.3.1.2 HVAC System Agent

HVAC System Structure

As mentioned in the previous section and as shown in the UML Figure 4.17 b and Figure 4.23, the HVAC system class structure is composed of a set of attributes and methods in addition to three subsystems classes: cooling generating subsystem, heat generating subsystem, and air circulation subsystem (FCU in our case). Each subsystem class also is composed of its own attributes and methods, as well as several component class instances such as chillers, cooling towers, pumps, boilers, fan, coil, etc. Since different types of components (i.e., chiller, pump, fan, filter, etc.) share the same structure and behavior, it could be created as an OOP class with its own attributes and methods. Each component has a single failure class instance that contains the component failure information resulting from the unexpected failure method, such as ID, age, repair cost, criticality,

and condition reduction. Component failure information was later consolidated into the subsystem failure instance.

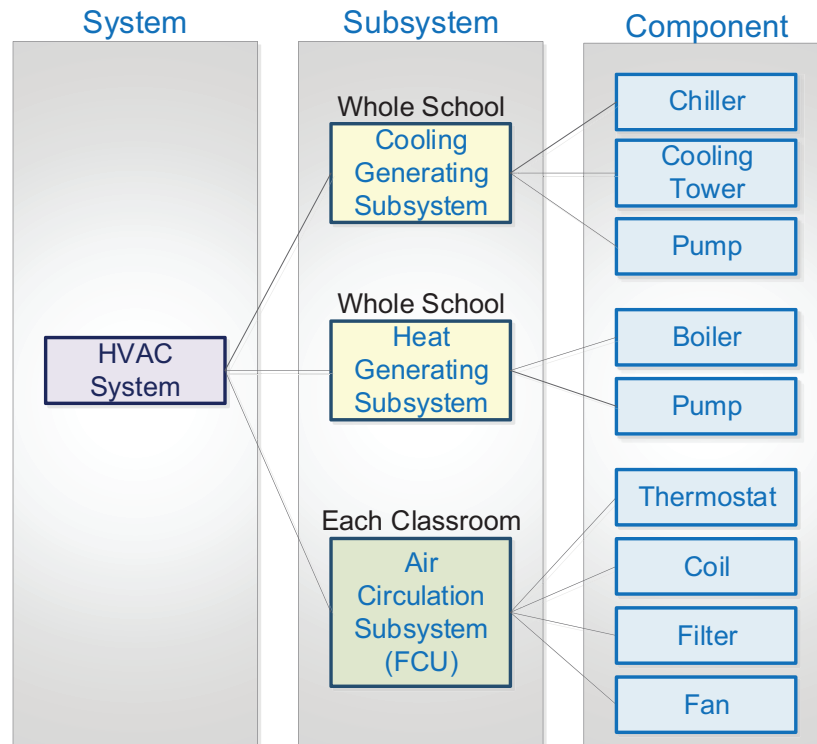

Figure 4.23 HVAC Agent Structure

HVAC System Performance

Condition index (CI) and status are used for evaluating HVAC system performance. Component CI is an indicator of the component condition and is a number between 0 and 1, where 1 indicates that the component is in perfect condition. CI is based on the ratio between repair cost to the replacement value and it complements FCI discussed in the literature review chapter where $(CI = 1 - FCI)$. Status, on the other hand, describes the component's performance and is divided into four levels:

- Level 3: $CI > 0.9$ indicates no performance efficiency loss.
- Level 2: $0.9 > CI > 0.8$ indicates low performance efficiency loss.
- Level 1: $0.8 > CI > 0.6$ indicates high performance efficiency loss.
- Level 0: $CI < 0.6$ or Critical failure: indicates the component is not working.

Figure 4.24 shows an example of the different interpretations of the FCU components' status values. Component status not only simplified the understanding of the CI number but also represented the non-linear relationship between the component age, condition, and performance as shown in Figure 4.25. This representation was very useful for calculating the probability of unexpected failure and for selecting the proper maintenance intervention. Another important benefit for having the status attribute was to overcome the limitation of the CI and repair cost dependency where expensive equipment may stop working because of faulty sensors or loose wires that are inexpensive to repair.

HVAC System Deterioration Modeling

As mentioned earlier, the condition of HVAC systems deteriorates with time or because of misuse and vandalism. Therefore, our HVAC system component class has a “deteriorate” method to represent the change in condition index (CI) and status. The deteriorate method includes four sub-methods: regular deterioration, electricity failure, vandalism, and unexpected failure. The regular deterioration sub-method represents the normal wear and tear and can be assumed linear over the period of the component useful life; but since we knew the recommended preventive maintenance for each component in addition to the recommended major preventive maintenance cost and frequency, we modified our assumption as follows:

$$\text{Annual Deterioration rate} = \frac{100 - \text{TH}}{\text{USL}} + \text{APM} + \frac{\text{MPM}}{\text{MPMF}} \quad (4.2)$$

TH = Threshold (TH is assumed 80%= good condition on CI scale).

USL= Useful service life in years.

APM = Annual preventive maintenance as percentage of original cost.

MPM =Major preventive maintenance as percentage of original cost.

MPMF = MPM frequency = number of years between major PM.

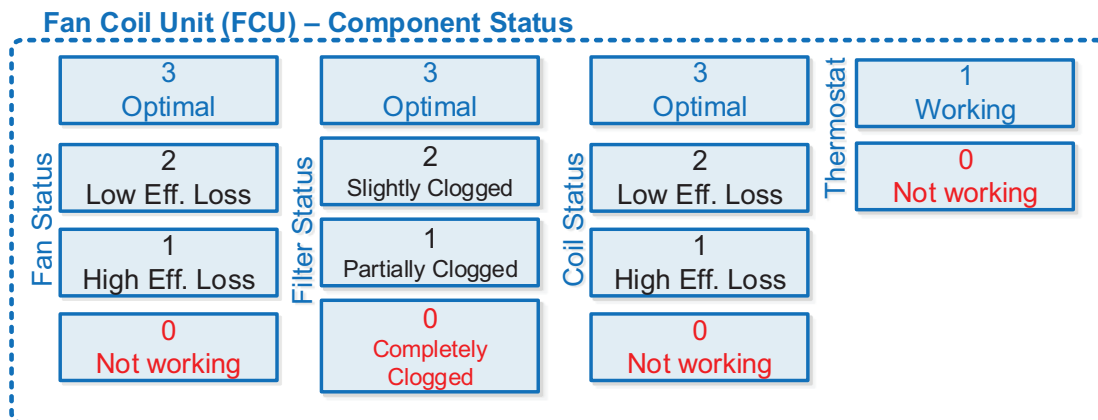

Figure 4.24 FCU Component Status Interpretation

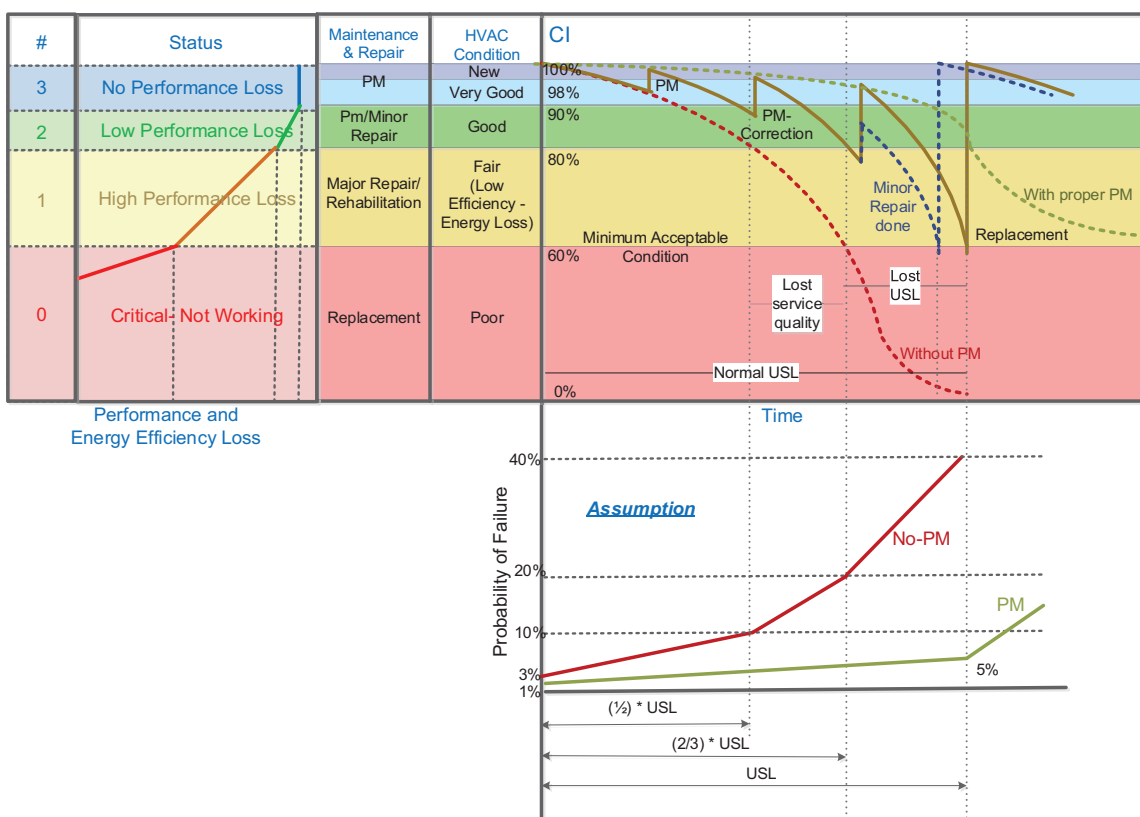
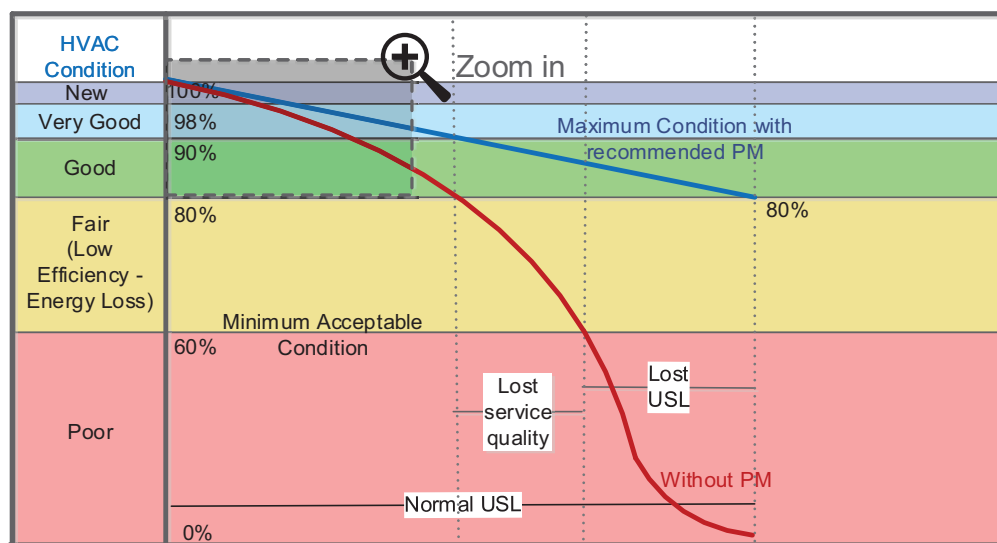
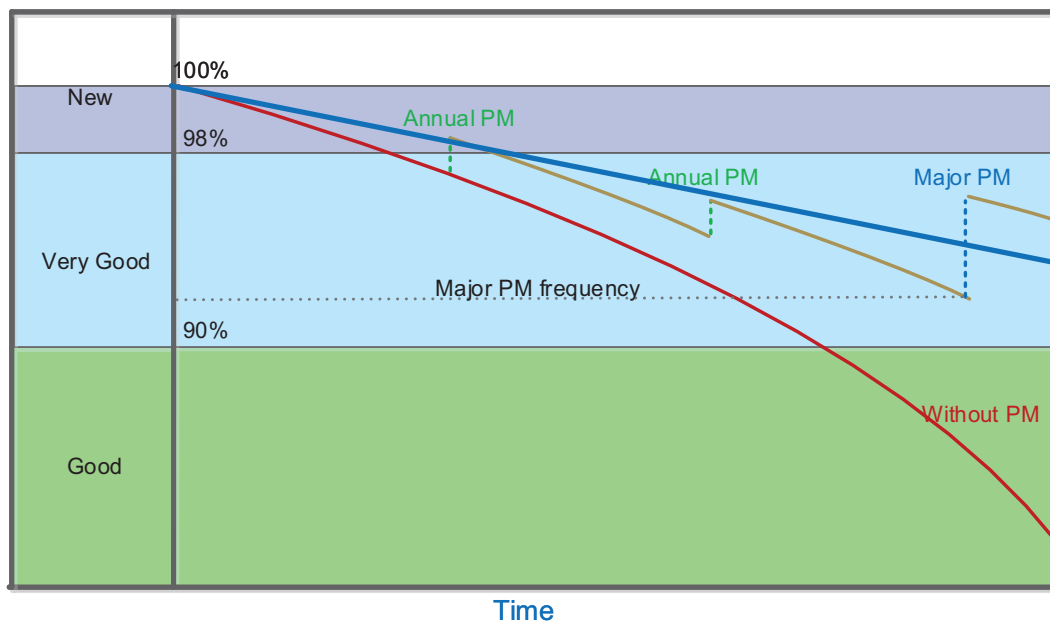

Figure 4.25 HVAC Component Deterioration Pattern and Its Relation to Failure Probability

The threshold was assumed to be 80%, which means that the equipment should be in good condition ($CI \geq 80\%$) throughout its USL period while doing the recommended annual and major preventive maintenance (the blue line in Figures 4.26 a and b). The deterioration rate from the equation above then was divided by 365 to convert the annual rate to the daily rate for use in the simulation.



a) General.



b) Close up.

Figure 4.26 HVAC Component Deterioration Pattern

Table 4.15 shows the HVAC system components with the recommended preventive maintenance values and the comparison between the linear method and the proposed method proposed in Equation 4.2. The USL maintenance values were taken from the life cycle cost analysis performed at California State University (Doe, 2001; Audin,2009).

Table 4.15 HVAC Components Deterioration Rates

Part	USL	Annual Deterioration Linear method (Maximum)	Annual PM	MPM	MPMF (Years)	Normal deter.	Major PM Yearly	Annual Deterioration Proposed Method
	A	$B=100/A$	C	D	E	$F=(100-80)/A$	$G=D/E$	$H=F+C+G$
AHU	15	6.67	4.0%	15%	10	1.33	1.5	6.83
FCU	15	6.67	3.0%	15%	10	1.33	1.5	5.83
Chiller	20	5.00	3.5%	30%	10	1.00	3.0	7.50
CT	15	6.67	5.5%	15%	10	1.33	1.5	8.33
Boiler	30	3.33	3.0%	10%	7	0.67	1.4	5.10
Pump	15	6.67	5.0%	10 %	5	1.33	2.0	8.33

In addition to the regular deterioration, HVAC components can experience unexpected failures that reduce the CI and/or causes the equipment to stop working. When thinking about HVAC equipment failures for the proposed model, three main properties were considered: probability of failure, condition reduction magnitude, and how the failure affects classroom IEQ. The probability of failure depends on the maintenance policies and is proportional to the component's age. Figure 4.25 shows the assumed values for probability of failure in the proposed model. With preventive maintenance, the failure probability was assumed to be linear and ranged between 1% and 5% over the component's USL. Beyond the component USL, the failure probability still may follow a linear pattern but with a steeper slope.

On the other hand, without doing the proper preventive maintenance, the probability of failure may follow an exponential curve reflecting the component deterioration behavior represented by the red dotted line in Figure 4.25. The curve was simplified into the three-line segments shown in the same figure. The first line started at 3% and increased linearly to 10% at the middle of the USL.

Then, the probability increased to 20% at $2/3$ of the USL, reflecting the rapid deterioration rate shown by the red dotted line when the condition changed from good to fair (yellow zone). The failure probability was expected to increase more rapidly to reach 40% at the end of the USL.

Failure magnitude depends on the component condition as shown in Figure 4.27. A random number between 0 and 100 was selected; and based on the component condition, the proper curve was chosen from the figure to evaluate the condition reduction magnitude. The repair cost was calculated since the condition is a cost-dependent variable, and failure can be critical or potentially critical, causing the component to stop working if not addressed.

The last two sub-methods deal with evaluating the probability of failure for the whole system, such as an electricity failure, or for a single component because of student vandalism or misuse. The probability of electricity failure is completely random while the probability of vandalism failure is based on a change in the student's IEQ satisfaction and their risky behavior values.

The failure effect on the classroom IEQ is discussed in the next section.

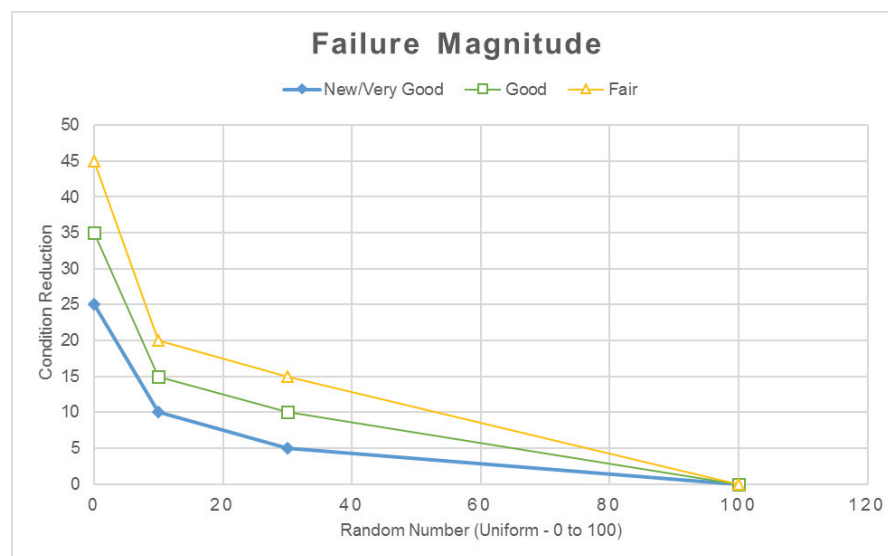

Figure 4.27 HVAC System Failure Magnitude Used in the Simulation

4.4.3.1.3 Classroom Agent

As mentioned in the previous section, a classroom's IEQ was evaluated using three attributes: thermal condition, IAQ, and noise level. Figure 4.28 shows the different interpretations for the IEQ attributes.

As shown in Figure 4.19, the thermal condition is a function of the outside temperature, FCU components status, and chiller/boiler system condition. Thermal condition can range from -3 (too cold) to 3 (too hot) where zero is the optimal value. Indoor air quality is a function of the fan and filter status as well as the classroom's overall average health. The noise level is a Boolean variable and could be true when the FCU fan status is larger than the filter status. IEQ severity consolidates the three attributes into a single number that describes the severity of the IEQ.

$$\text{IEQ severity} = \frac{\alpha * (\text{IAQ}) + \beta * (\text{Thermal Condition}) + \gamma * (\text{noise level})}{\alpha + \beta + \gamma} \quad (4.3)$$

Where α, β, γ are weight factors, and the value of IAQ, thermal condition, and noise level is converted to be comparable to each other.

The classroom's SBS threat level ranged from 0 (no threat) to 1 (maximum threat) and is a function of the classroom IAQ and the thermal condition. SBS threat level starts with zero when IAQ=zero and increase with negative IAQ values and higher temperatures.

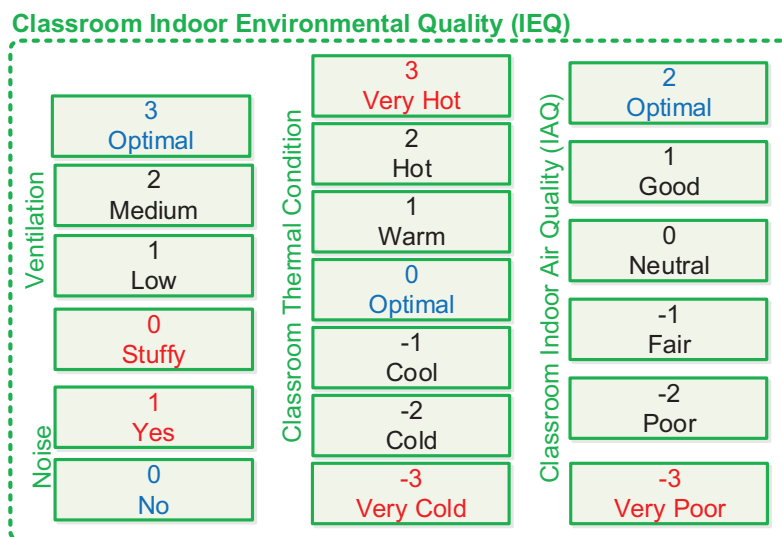

Figure 4.28 Classroom IEQ Attributes Value Interpretation

4.4.3.1.4 Facility Management Department (FMD) Agent

HVAC System Failure Prioritization Model

The proposed failure prioritization model aims to create a risk-ranked failure list to prioritize the needed repairs identified during simulation. With limited maintenance budget, it is important to repair the highest risk failures first, such as critical failures that cause the system to stop working. The risk rank used in the model is a decimal number composed of two parts:

- Part (a): digits to the left of the decimal point. The part (a) number is a four-digit number each corresponds to one of the following factors: activeness, status, deferring consequences, and scope.
- Part (b): digits to the right of the decimal point. The part (b) number is less than 1 and is related to the repair cost/deferred cost ratio and/or the change in student performance.

Part (a) description is shown in Figures 4.29 a and b, where the risk ranked ordered list starts with the highest priority failures in terms of the following:

1. Activeness: Active subsystems need to be repaired before subsystems that are currently not in use. For example: during the winter season, cooling generating subsystem failures will be pushed to the bottom of the priority list because that subsystem will not be active during that period.

2. Component Status: Critical failures with status=0 are at the top of the priority list.
3. Deferring Consequences: Some deferred failures could become critical or will cost more to repairs if not addressed.
4. Failure Scope: Some failures affect the whole school while others are limited to classroom area. Larger affected areas have higher priority over smaller areas.

The order of the previous factors dictates its importance between other factors as shown in Figure 4.29 b below.

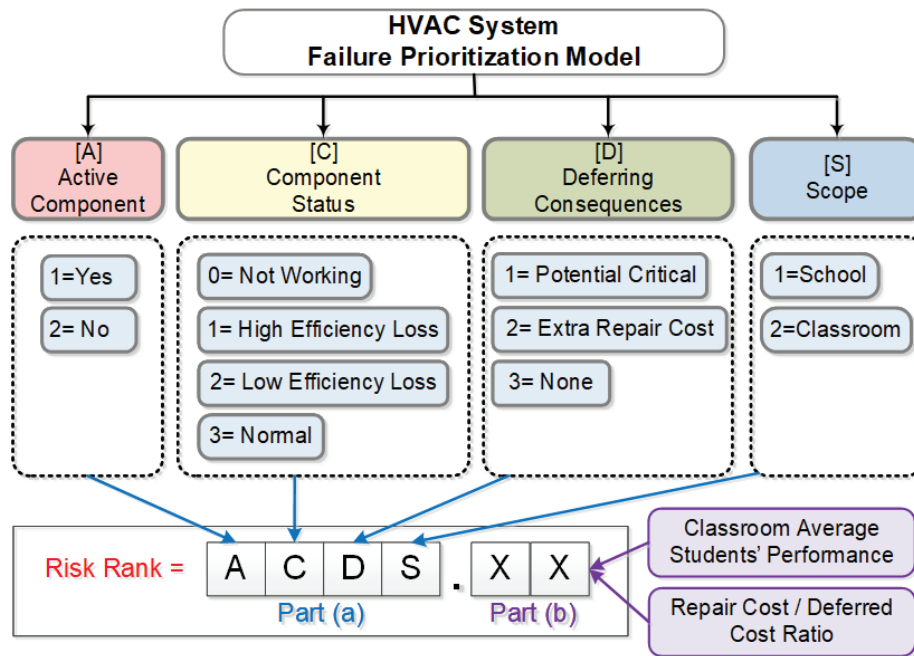

a) Description

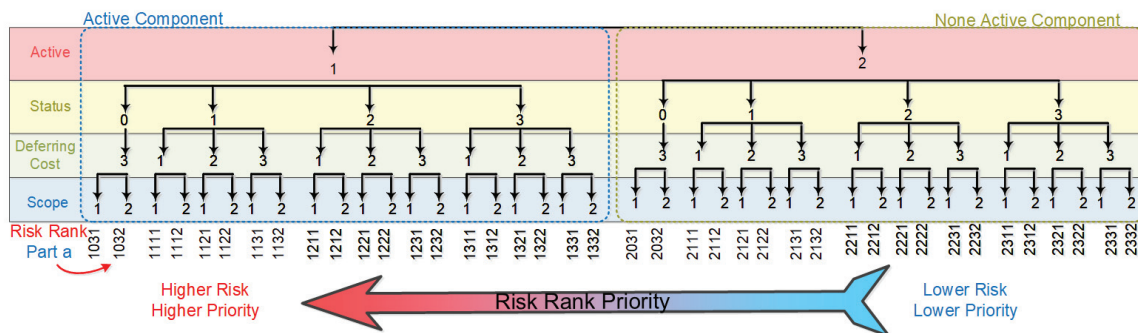

b) Numbering

Figure 4.29 HVAC System Failures Prioritization Model

Part (b) depends on school administration directions. For example, part (b) can be based on the repair cost to the deferred cost ratio, the change in average student performance, or an average of the two values.

The first option was the repair cost to the deferred cost ratio, which was calculated as follows:

$$\text{Option 1: Part (b) = Ratio} = \frac{\text{Failure Repair Cost}}{\text{Failure Repair Cost} + \text{Expected Deferred Cost}} \quad (4.4a)$$

or Ratio = 0.99, if Ratio \geq 1.

A smaller ratio value means a higher deferred cost and higher priority.

The second option is the negative change in student performance of the affected area and is calculated at follows:

$$\text{Option 2 : Part (b) = } 1 + \text{Classroom average student performance change} \quad (4.4b)$$

For average change less than zero part (b) will become less than 1. Otherwise, part (b)= 0.99, smaller values mean higher priority.

The third option is simply the average of the first two options.

4.4.3.1.5 School Administration Agent

School administration (SA) agent is a single agent responsible for setting maintenance policies and managing a general operating budget that is shared between the O & M and instructional funding. SA agent compares the complaint levels and approves maintenance budget increase if there are more complaints from parents than teachers. A weight factor is added to give more weight to one side over the other if needed.

4.4.3.1.6 Parents Agent

There is a single parent agent associated with every student. Parents communicate with school administration regarding the poor quality of school facilities and its negative effect on their children's health and performance. The probability of parent complaints is associated with the average value of a negative change in student performance, SBS intensity, and sick leave percentage.

$$\text{Parents Complain probability} = \frac{|\Delta \text{performance}| + \text{SBS intensity} + \text{Sick Leave percentage}}{3} \quad (4.5)$$

$$\text{Total parents complain level} = \frac{\text{Total number of complains}}{\text{Total number of students}} \quad (4.6)$$

4.4.3.1.7 Teachers Agent

Each classroom agent includes a single teacher's agent that represent the average values for teachers working in the same classroom. Teacher performance is affected by IEQ satisfaction and SBS intensity. On the other hand, teacher complaints are associated with funds deducted from instructional budget and is equal to

$$\text{Teacher complaint level} = \frac{\text{Total teaching budget reduction} + \text{New M\&O increase request}}{\text{Initial teaching budget}} \quad (4.7)$$

4.4.3.2. Simulation Execution and Case Study

The model was implemented using AnyLogic 7.1.2 simulation development software. The simulation was assumed to take place in an elementary school with 40 classrooms and 25 students in each classroom. It also was assumed that the students spend all typical periods in the same classroom and that the teachers move between classrooms. Table 4.16 shows the school prototype details used for the case study.

Table 4.16 School Prototype Information

School Level	Elementary School
Grades	1 to 5
Location	Indiana, USA
Size	1000 Students
Total buildup area	195,750 sq. ft
Construction cost /sq. ft	\$ 142.4 /sq. ft (R.S. Means)
Construction cost	\$ 27,874,800
Average classroom size (sq. ft)	1067.5 sq. ft
#periods/day	6 periods
Number of typical classroom	40 classrooms
Class Size Capacity	25 students
Total Core Academic Area	42,700 Sq. ft (22%)
Other Areas	153,050 Sq. ft (78 %)

According to Bush et al (2011), a typical high school has a minimum of 180 instructional days in a school year with six hours of instruction in each day. For this simulation, our school year was divided into two semesters. Each semester had 18 weeks (equivalent to 90 instructional days based on five working days per week). The school day started at 8:00 am and ended at 3:00 pm and had six periods and a recess between classes. A visual description of the simulation timeline is shown in Figure 4.30 below. Each time step in the simulation represents a single day in the model. Every seven days represent a week and every 52 weeks represent a year. The model began on the first day in the first semester and ran over a one-year time horizon.

The simulation can run beyond one year, but all agents would reset except for the HVAC system agent. The figure also shows how the HVAC system alternates between the chiller and boiler subsystems during different seasons of the year and how the fall season can negatively impact air quality due to allergies and flu viruses.

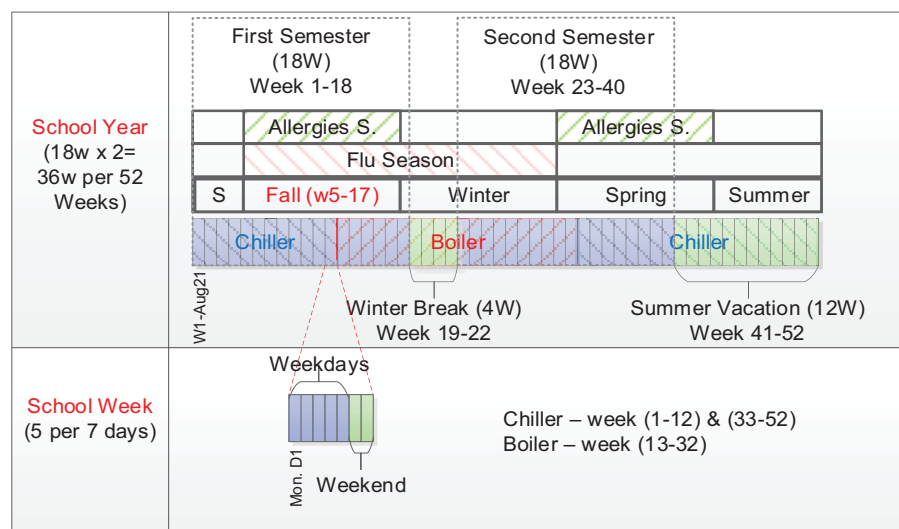

Figure 4.30 Simulation Timeline

The HVAC system used for the school prototype was designed by HVAC specialists and is shown in Tables 4.17 and 4.18. It was assumed that the 40 classrooms used a subset of the total HVAC system as shown in Table 4.19. Table 4.20 shows the typical maintenance value for the presented case study.

Table 4.17 HVAC System Description

HVAC Subsystem	Description
Heat Generating equipment	Gas fired boiler
Cooling Generating	Water cooled chiller with cooling tower (Centrifugal Compression)
Air Distribution equipment	Air handling unit (AHU) in open areas & Fan coil units (FCU) in rooms

Table 4.18 HVAC System Total Cost

	Qt	Total Cost (2015 \$)	Percentage (Total)	Average Unit Cost (2015 \$)	% (unit)
AHU	19	\$ 564,016.50	28.5%	\$ 29,685.08	1.50%
FCU	74	\$ 229,896.23	11.6%	\$ 3,106.71	0.16%
Chiller	3	\$ 765,490.50	38.6%	\$255,163.50	12.88%
CT	3	\$ 207,562.50	10.5%	\$ 69,187.50	3.49%
Boiler	2	\$ 94,316.40	4.8%	\$ 47,158.20	2.38%
Pumps	15	\$ 120,220.20	6.1%	\$ 8,014.68	0.40%
Other		\$ 1,363,473			
Total		\$ 3,344,976			

Table 4.19 HVAC System Used for the Simulation (40 Classrooms)

	Qt	Average Unit Cost (2015 \$)	Total Cost (2015 \$)	Percentage %	USL
FCU	40	\$ 3,106	\$124,268	23%	15
Chiller	1	\$255,163	\$255,164	47%	20
CT	1	\$ 69,187	\$69,188	13%	15
Boiler	1	\$ 47,158	\$47,158	9%	30
Pumps	6	\$ 8,014	\$48,088	9%	15
			\$543,866		

Table 4.20 Case Study Budget Information

Description	Value
Total buildup area	195,750 sq. ft
Construction cost /sq. ft	\$ 142.4 /sq. ft (R.S. Means)
Construction cost (CC)	\$ 27,874,800
HVAC System Total Cost (12% CC)	\$ 3,344,976
Recommended Total Maintenance Budget (2%CC)	\$ 557,496
Recommended Total HVAC system maintenance Budget (16% of total maintenance)	\$ 89,199
Partial HVAC system used in simulation for 40 CR	\$ 543,866
Recommended maintenance budget for the Partial HVAC system used in the simulation	\$ 14,495

As shown in Figure 4.32, the simulation started with the HVAC system deterioration. HVAC deterioration affects its performance and in turn affects the classroom IEQ. The quality of the classroom indoor environment will affect teachers' satisfaction and the SBS intensity, and as a result will affect teacher performance. Similarly, IEQ will affect students IEQ satisfaction, which may modify conventional and risky behaviors of students. IEQ also may affect the SBS intensity and health of students, which will be used later for modifying the student performance value. The next step was evaluating the peer effect, where a behavior-changing incident interaction can take place based on the other student's popularity and friendship relations. Later, student performance was evaluated and accordingly the parent complaint level was computed. Then, the FMD evaluated the HVAC system performance and total repair cost in addition to calculating the risk rank for each failure and sorting the repair list according to risk rank values. If the needed repair budget is not sufficient, FMD asked the school administration for a budget increase. School administration then compared the complaint levels between parents and teachers and decided to approve or reject the maintenance budget increase request. Lastly, the FMD maintains and fixed the current failure using the available budget according to the school administration's decision.

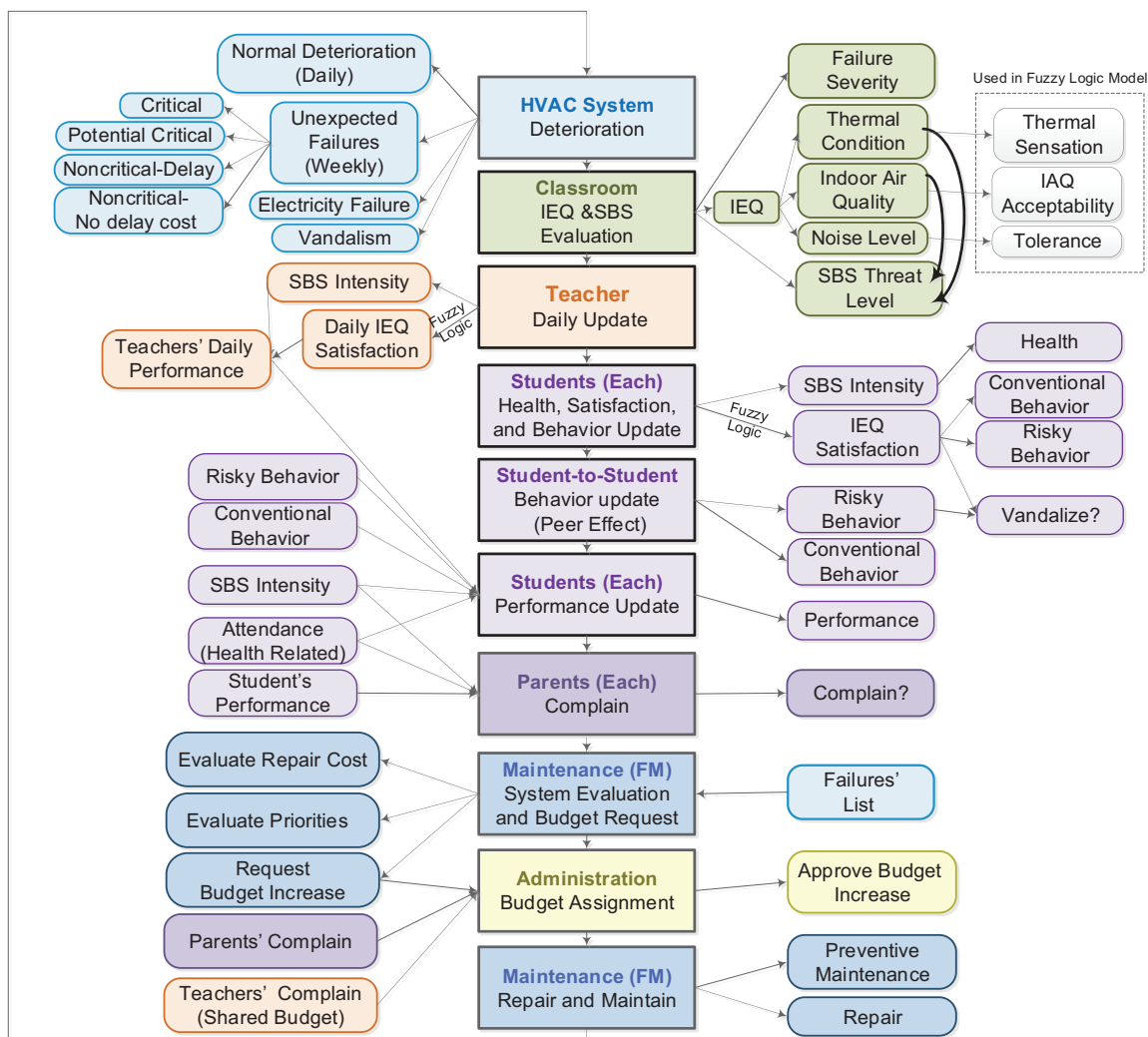
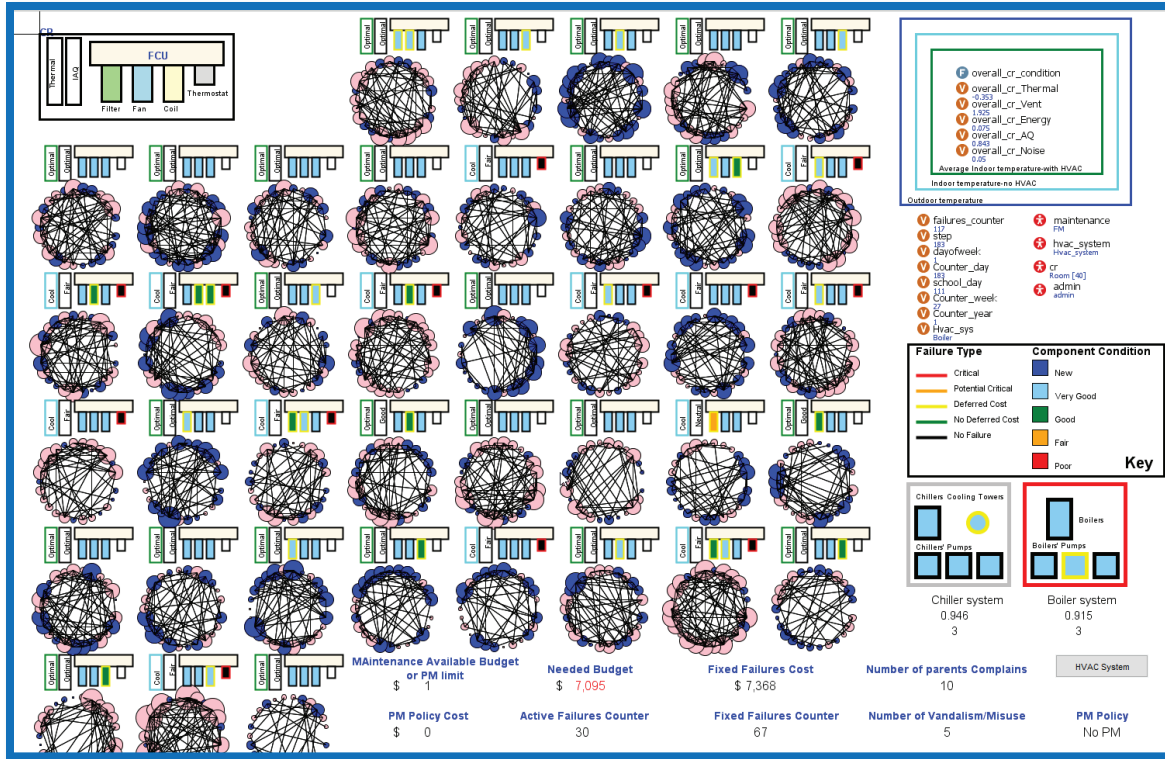
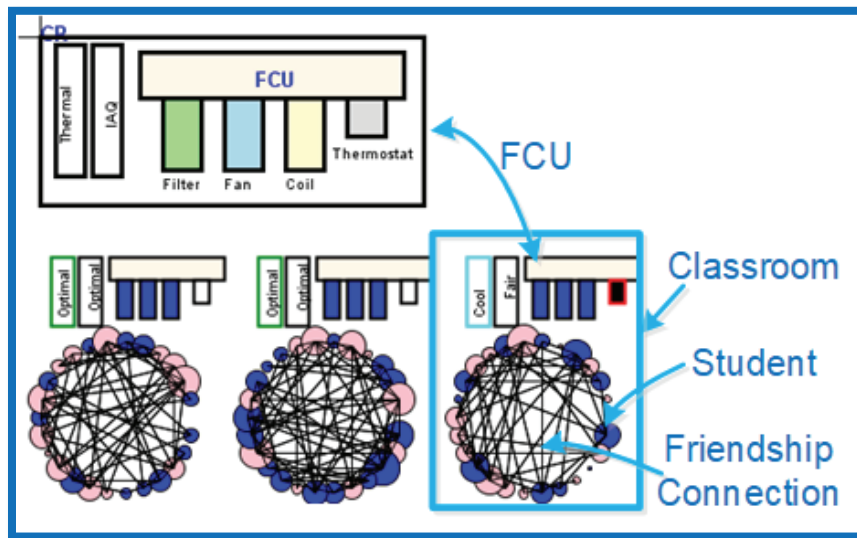

Figure 4.32 Simulation Process

Figures 4.33 to 4.36 and Table 4.21 show the example for the model execution and comparison between the results for reactive and preventive maintenance for the whole school, a sample classroom, and a sample HVAC component.



a) General.



b) Close-up.

Figure 4.33 Simulation Main Interface

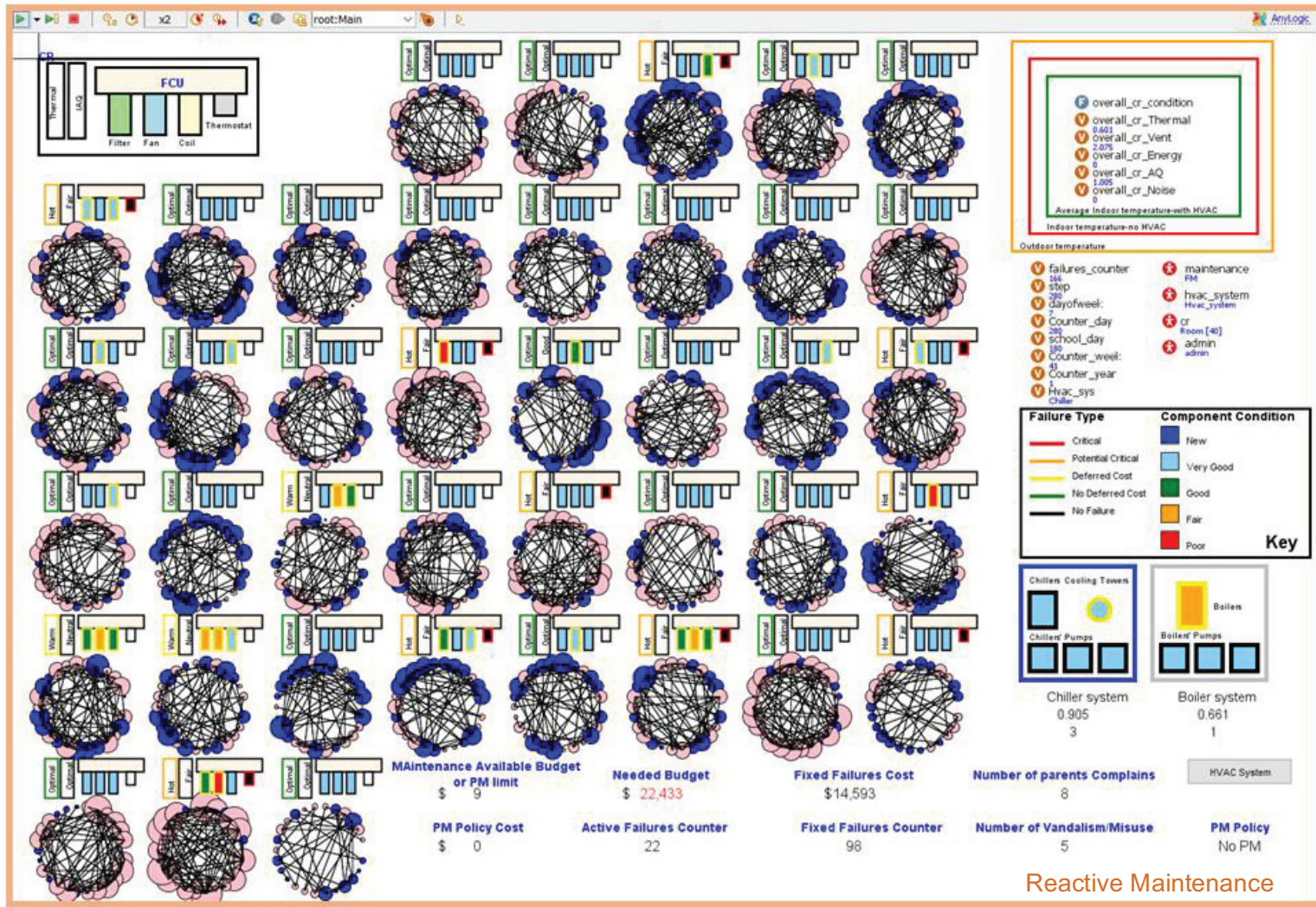

a) Reactive Maintenance.

Figure 4.34 Main Results at the End of the Simulation

Figure 4.34 continued

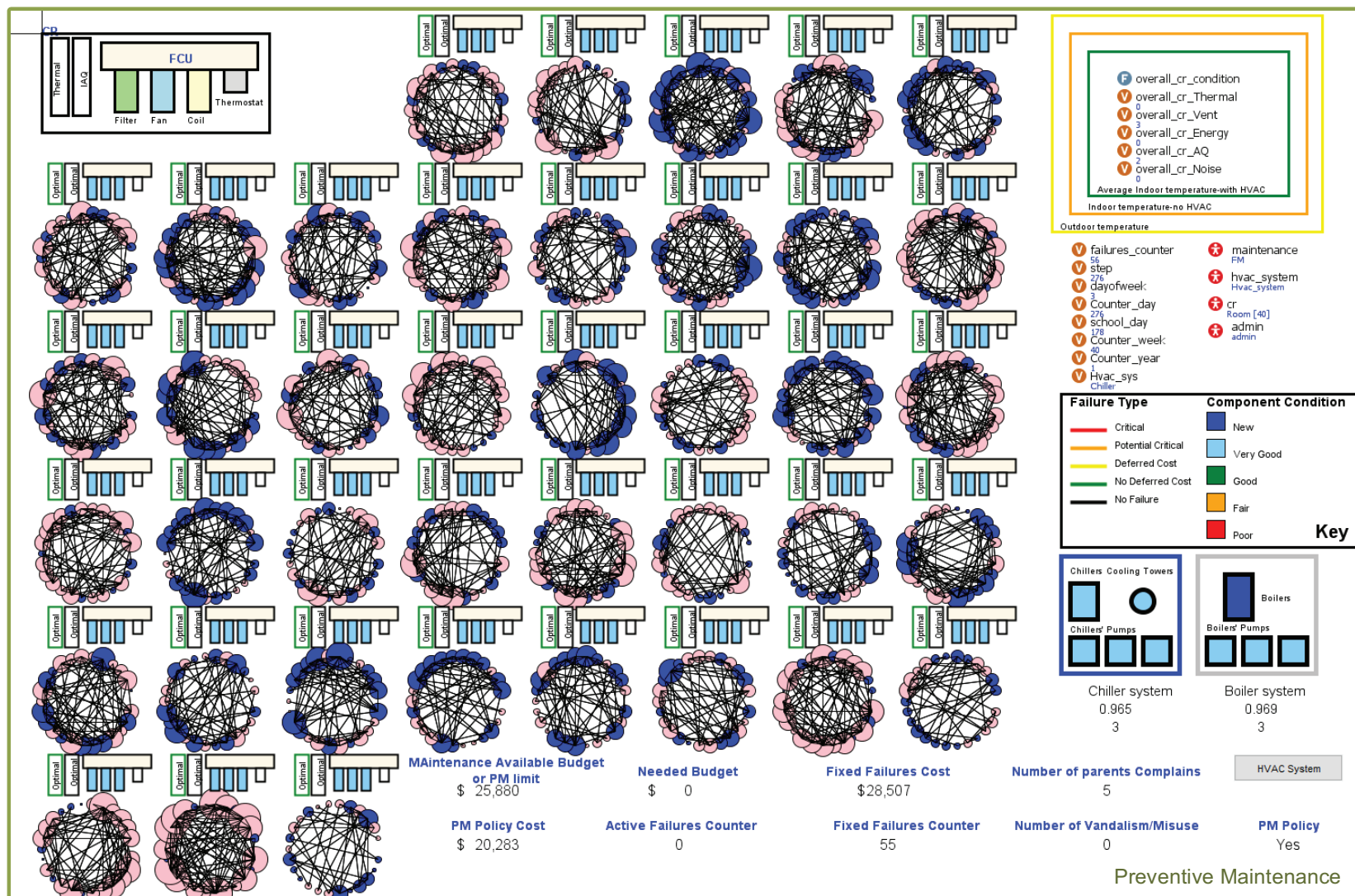

b) Preventive Maintenance.

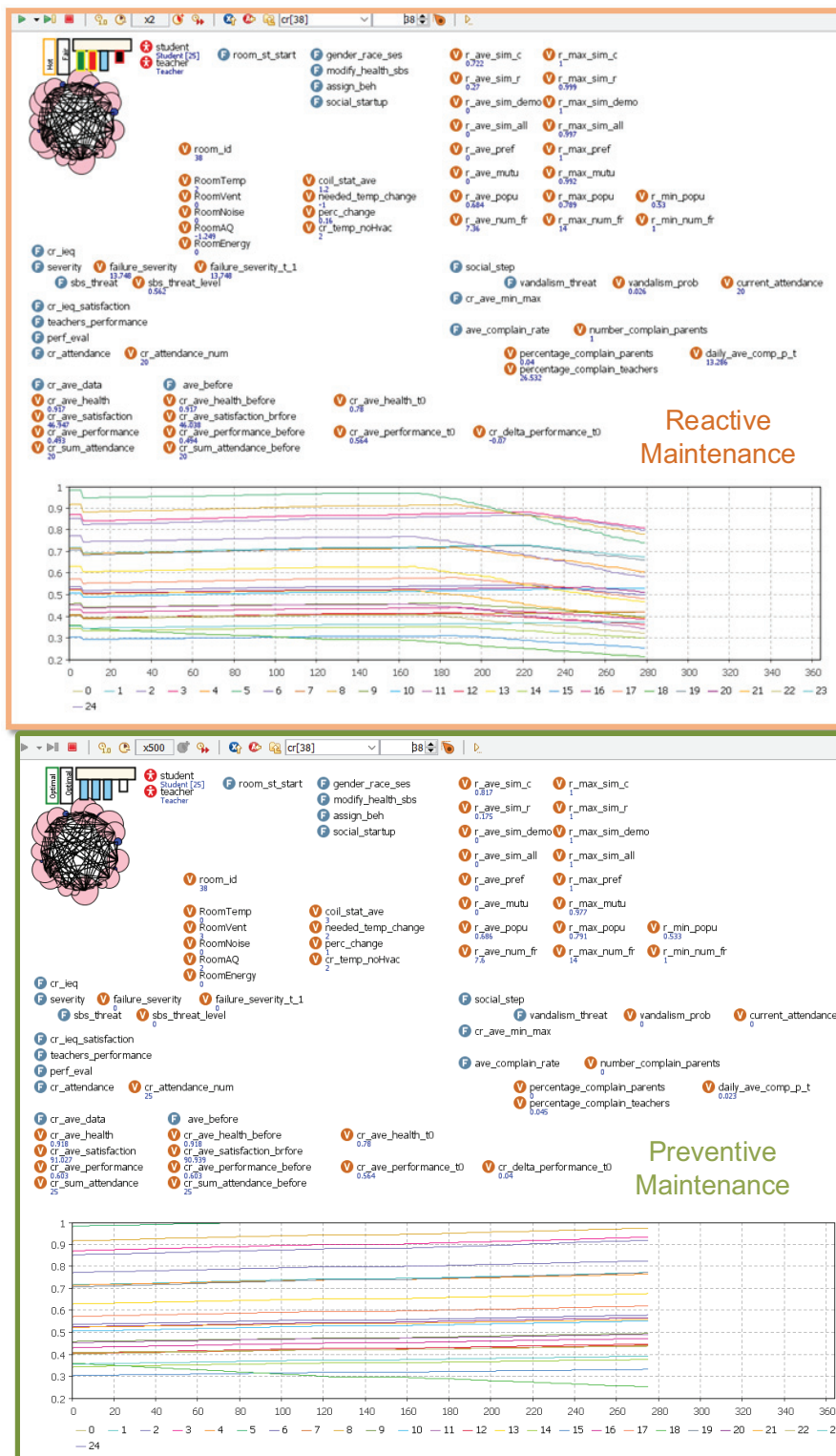

Figure 4.35 Reactive and Preventive Maintenance Results for Classroom at the End of The Simulation

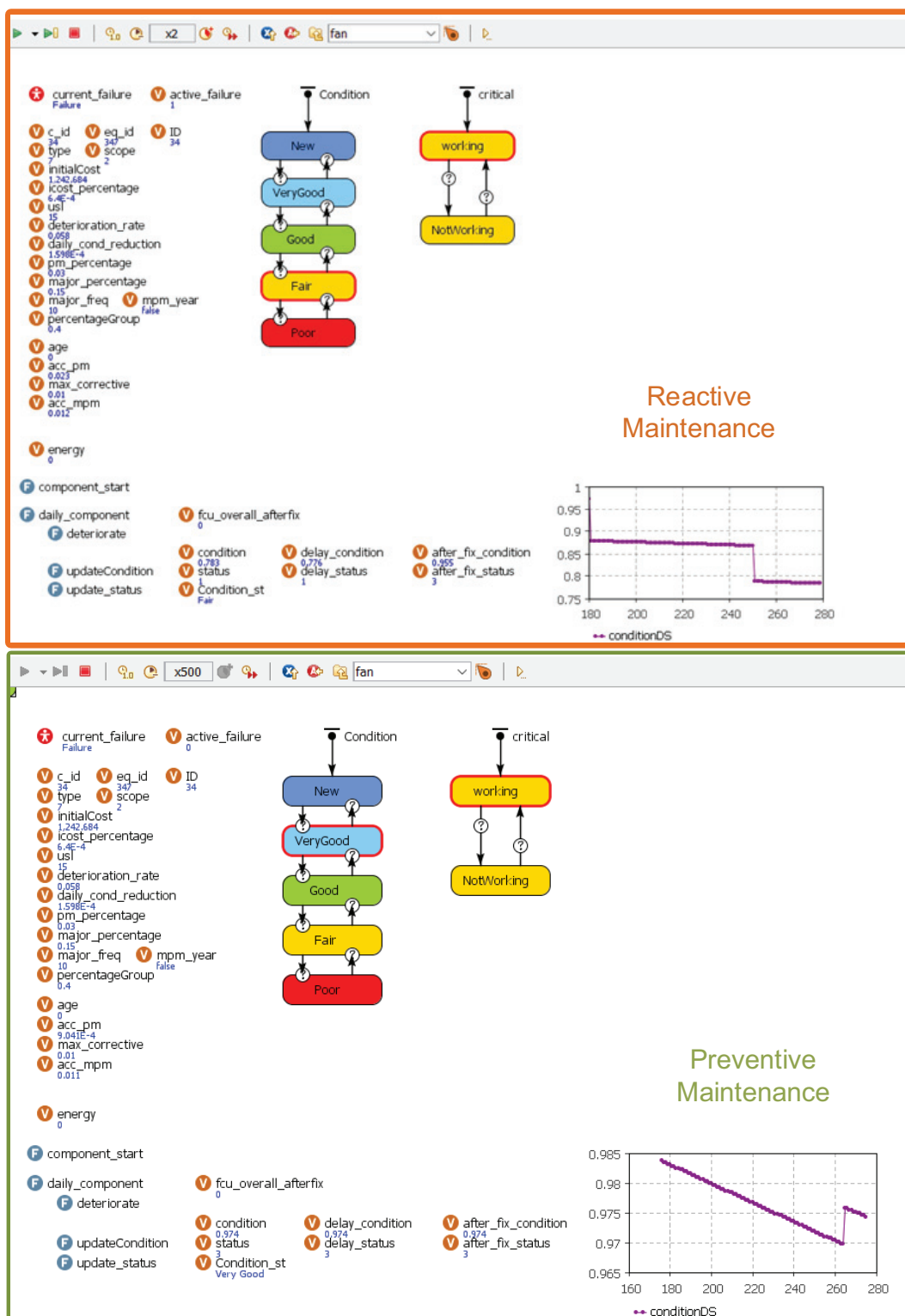

Figure 4.36 Reactive and Preventive Maintenance Results for HVAC Component at the End of the Simulation

Table 4.21 Model Results at the End of the Simulation

Variable	Reactive	Preventive
Startup Cost -School Administration	\$ 0	\$ 20,283
Startup Available Budget -FM (assigned by school administration, or PM limit)	\$ 2,719	\$ 54,387
Number of Total Failures	120	55
Fixed Failures Repair Cost	\$ 14,593	\$ 28,507
Deferred Maintenance Repair Cost	\$ 22,433	\$ 0
Number of vandalism/ misuse incidents	5	0
Overall Chiller Subsystem Condition	0.905	0.965
Overall Boiler Subsystem Condition	0.661	0.969
Number of sick leaves / student	2.1	0
Average IEQ Satisfaction	75%	91%

4.5 Model Validation and Verification

The main goal of any facility management decision support system is to better understand the complex relations between the main stakeholders and to test the effect of different management strategies not only on the facility condition but also on the health and performance of the occupants. A comprehensive understanding of the situation at hand can help decision-makers optimize the use of the limited available funds to get the best possible results.

The proposed model aims to evaluate the impact of different management policies rather than to predict or forecast certain values (facility value, demand growth, etc). To test and evaluate the applicability of the model, an elementary school prototype was used as a case study, which was discussed in the previous section.

Since human agents play an important role in our model, traditional validation techniques and using historical data was not feasible because of the complex nature of the system in addition to the inherited uncertainties of the human behavior. ABM is best validated using literature review data, industry guidelines, case studies, and expert opinion.

For example, it was important to understand how the HVAC system works to evaluate and quantify its effect on the room IEQ. Also, cost and maintenance data were taken from industry guidelines and actual life cycle cost analysis examples. Moreover, intensive meetings with HVAC system specialists and facility managers were conducted to validate the conceptual model and to design the HVAC system used for the case study. The user interface and graphical presentation used in the case study simulation also helped in the validating that the model assumptions and logics were reasonable as shown in Figure 4.37.

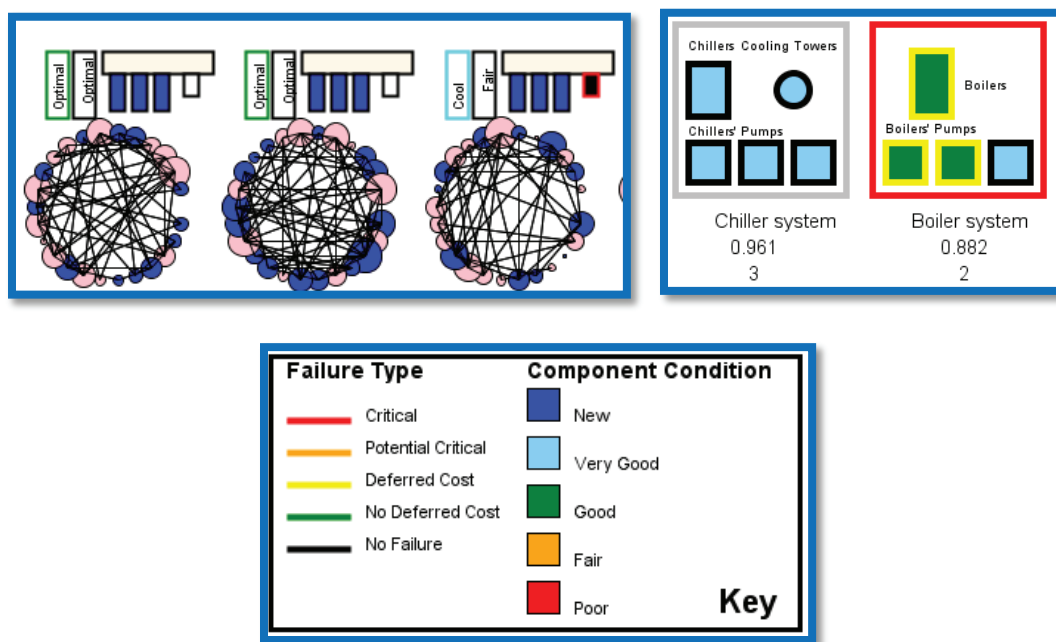

Figure 4.37 Color Coding Used in the Simulation Visualization

The second part of the testing process deals with software verification to determine if the created software code correctly represents the model. Code verification was conducted through the following:

- a- Testing each method/function separately to make sure it is performing the tasks as planned. This test was done by inserting a [print] command throughout the code to check the correctness of the program logic as shown in Figure 4.38.
- b- Using graphic (visual presentation) of the different agents and color coding as shown in Figure 4.37.
- c- Using a spreadsheet where applicable to check the possible results ranges.

```

if(y.failureID<100)//FCU
{ind=y.failureID;
traceln("fcu failure ID = " + (y.failureID)+", fcu ind= "+ ind+", compare= "+ y.compare_st_last +", fixed= "+ y.fixed);
main.hvac_system.CR_FCU.get(ind).fix_fcu_all();
}
else if (y.failureID<200)//chiller system
{ind=y.failureID-101;
traceln("chiller failure ID = " + (y.failureID)+", chiller ind= "+ ind+", compare= "+ y.compare_st_last +", fixed= "+ y.fixed);
main.hvac_system.chiller_sys.chsys_components.get(ind).fix_failure();
}
else //Boiler system
{ind=y.failureID-201;
traceln("boiler failure ID = " + (y.failureID)+", boiler ind= "+ ind+", compare= "+ y.compare_st_last +", fixed= "+ y.fixed);
main.hvac_system.boiler_sys.bsys_components.get(ind).fix_failure();
}

```

```

=====
all failures order= 4, fixed= false
fcu failure ID = 34, fcu ind= 34, compare= 1332.4926545764652, fixed= false
start fixing failure number13.0, id= 34
all failures order= 5, fixed= false
fcu failure ID = 7, fcu ind= 7, compare= 1332.7129193583114, fixed= false

```

Figure 4.38 Code Verification Using Print Command to Check Results During Exclusion

4.6 Summary

In this chapter, we introduced a tactical level decision support ABM tool to provide decision-makers with new insights about the effects of different management styles on a school system. The proposed model simulates the complex mutual interactions between the main stakeholders and allows school administration to experiment with different management strategies to evaluate their effect on the overall system performance in the short and long term. The model was implemented using a case study where the user can select the maintenance strategy and repair prioritization method and examine day-to-day system progress. The main challenge in developing the current ABM was trying to capture accurate agent behavior for the system stakeholders and to translate this knowledge into a quantitative relation rather than a qualitative one, especially with the inherited uncertainty of human behavior. This research also showed that asset management modeling requires a holistic bottom-top approach rather than asset-centric top-down approach. The research concluded that our proposed ABM has high potential as an asset management tool to give decision-makers a holistic understanding of the system dynamics.

CHAPTER 5. AGENT-BASED STRATEGIC DECISION-SUPPORT SYSTEM FOR EDUCATIONAL FACILITIES MANAGEMENT: MAINTENANCE BUDGET ALLOCATION MODELING

5.1 Overview

According to the ASCE 2017 report card, K-12 public school infrastructure is now in poor condition due to an annual funding shortage of \$38 billion. While school districts are committed to providing a safe and suitable learning environment for their students and at the same time keep up with the nonstop enrollment growth and the evolving educational requirements, this nationwide funding shortage has forced school districts to make tough decisions to optimize their maintenance expenditures. Many studies have addressed this shortage over the last three decades and noted the effects that the condition of school facilities can have on student performance.

This chapter proposes a strategic level agent-based model (ABM) that can evaluate the effects of different budget allocation strategies on the overall condition of school facilities and student achievement over time. The proposed model aims to improve the overall condition of the facilities as well as student performance through effective utilization of maintenance resources. Therefore, this model can serve as a policy decision-support tool for school facilities management since it simulates and analyzes the complex interactions between the various facility components and student achievement.

This chapter is divided into five parts as shown in Figure 5.1. First, the introduction outlines the problem and provides an overview of the theoretical model, thereby explaining the relationship between student achievement and the condition of school facilities. Then, the SoS methodology is demonstrated in three phases (definition, abstraction, and implementation), which is followed by model validation and verification and the chapter summary and our conclusions.

Note that the theoretical model proposed here was published in conference paper (Albader & Kandil, 2013).

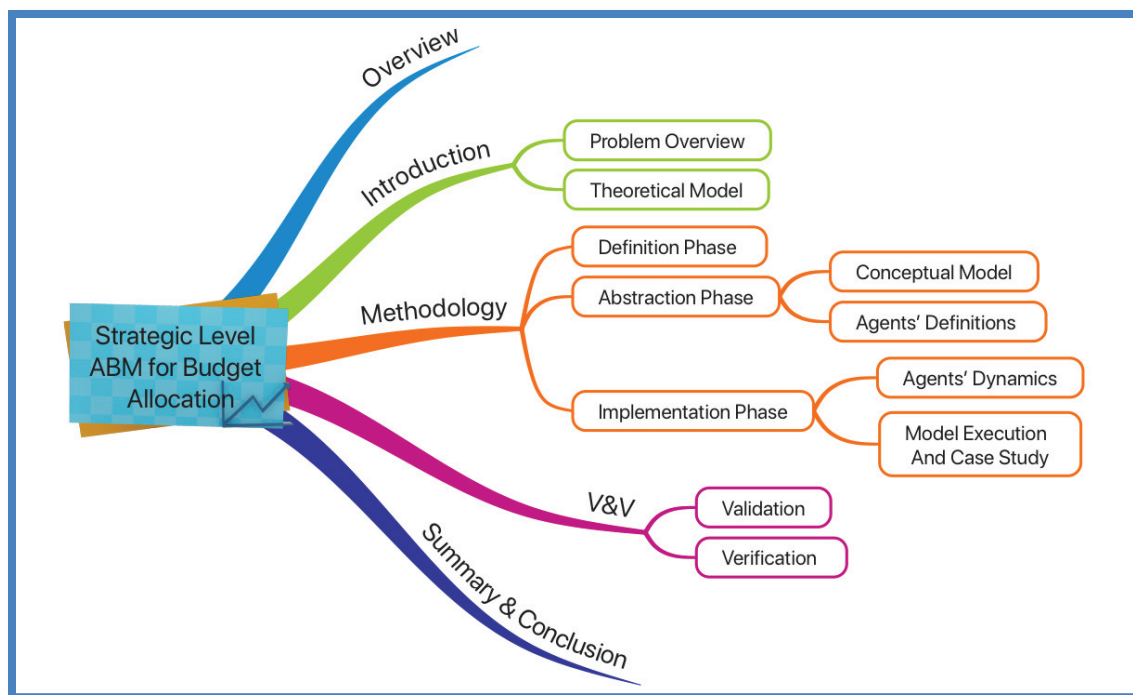

Figure 5.1 Strategic Level ABM Mind Map

5.1 Introduction

5.1.1 Problem Overview

A school's maintenance budget allocation strategies and their effects on the overall quality of their facilities over time are highly correlated with the quality of the education provided to their students. Elements such as air quality control, acoustics, and mechanical, electrical, and structural systems influence the satisfaction and performance of teachers and students as shown in our literature review. The depreciation of these systems is unavoidable, and it is the school administration's responsibility to maintain them to at least the minimum requirements needed to achieve a satisfactory educational environment. Even minor changes in these conditions may cause major revenue or enrollment changes. However, such changes can be gradual and usually are not noticed until they reach a critical level, at which time the solutions may not be effective and/or too expensive to implement. School administrators, as the main policy-makers for schools, need to be able to predict facility deterioration and the resulting emergent behavior of the stakeholders to better study the effects of different budget allocation strategies. Maintenance strategies are usually

the solutions administrators use to achieve their goals of improving student performance and avoid losses in property value. The proposed model can outline a system that can help decision-makers test the effects of different maintenance allocation strategies on student performance. The model was tested using maintenance budgets allocation strategies based on the school's gross area, enrollment size, condition, student performance, parent satisfaction, requested budget, and equal share.

5.1.2 School Facilities Condition and Student Achievement Theoretical Model

The relationship between the condition of school facilities and student achievement is complex because of the multiple contributing variables. As discussed earlier in the literature review, many theoretical models have examined the relationship between school building condition and student outcomes. Cash (1993), Lemasters (1997), Lanham (1999), Lackney (1999), Al-Enezi (2002), Mendell and Heath (2005), and O'Sullivan (2006) created or modified theoretical models describing the relationship between school facilities and student outcomes based on their extensive literature review. Cash (1993) created a theoretical model suggesting some potential elements that affect the school facilities condition and therefore influence student achievement. Cash indicated that leadership and financial capabilities affect the maintenance and custodial staff, which then can influence the condition of the facilities. Cash further stated that the condition of facilities impacts the satisfaction levels of students, parents, and teachers. Parent and teacher satisfaction also can affect student perception of the facilities and may impact both their academic achievement and behavior. Therefore, the condition of the school facilities, which is the outcome of the acts and financial capability of the decision-makers, can impact student achievement and behavior. Lanham (1999) modified Cash's model by recognizing the direct and indirect impacts of the condition of school facilities on the performance of elementary school students. Lanham's model assumes that administrative decisions, funding priorities, and deferred maintenance have direct impacts on the condition of the facilities and that student achievement can be affected indirectly through the condition of the facilities. Like previous models, Lanham's model adds deferred maintenance to the list of significant factors contributing to the deterioration of school buildings, which is the main interest of this research.

5.2 System of Systems (SoS) Modeling Approach and Methodology

DeLaurentis (2005) describes the “Proto method” for the development of SoS simulations. The Proto method starts with the definition phase, which aims to gain an understanding of how the system works by brainstorming and reviewing the related literature. The second phase is the abstraction phase in which the main stakeholders and their interrelations are identified, and the simulation framework is created. The final phase is the implementation phase, where the simulation model is created and validated. The following subsections discuss the Proto methodology for the proposed model in more detail.

5.2.1 Definition Phase

Schools are a major component of our society, and the continuing decreases in educational quality and funding have presented the U.S. with major challenges that could have implications not only for students, but also for the future of the country. According to the National Center for Education Statistics (Chaney et al, 2007), the estimated cost of school building repairs and maintenance for the entire U.S. was \$322 billion, and about 60% of the country’s schools had at least one major feature in desperate need of repairs. The study also indicated that the lack of doing needed repairs and maintenance may not only affect the safety of students and school staff, but also the performance and morale of students and teachers. However, with the current funding crisis affecting the country and subsequent major cuts in school budgets, decision-makers face a great challenge in selecting the best strategy for allocating adequate funding for maintenance. Maintenance usually takes a back seat during the school budget allocation process because maintenance can be deferred over more pressing needs.

The Chicago public school system is a good example of the challenging situation faced by school districts throughout the country. In 2013, the Chicago Board of Education voted to close 50 underutilized public schools and relocate approximately 12,000 students to other schools (Gordon et al., 2018), with the expectation of saving \$560 million in capital costs and \$43 million in operating costs over the ensuing 10 years. There was a major problem that was not considered in making the closing decision to decrease spending since the schools that do remain open will now

see a large influx of new students, which will undoubtedly accelerate building deterioration and decrease education quality (Rich & Yaccino, 2013) (Gordon et al., 2018).

However, Chicago is not an isolated case. Districts nationwide are closing underutilized schools. Approximately 2,000 schools (2%) are closing annually, affecting more than 250,000 students; and less than 20% of the closed schools are being replaced fully or partially with new construction (Gallagher & Gold, 2017).

According to Tilsley (2017) and as shown in Figures 5.2 and 5.3, closing schools in high poverty areas can increase the community unemployment rate, which can lead to an increase in crime and force families and teachers to move to a safer area, lowering the district population and land values that would result in lower property taxes and less local funds for school operating needs. Therefore, closing schools affects the whole community, putting community cohesion and quality of life at risk. A stable population is essential for improving education and building stronger communities. On the other hand, closing underutilized schools also can affect the performance of the other schools in the same school district where the students from the closed schools are relocated to other schools in the area. Classroom density and students to teacher ratio necessarily will increase, which can affect the performance and morale of both students and teachers and in turn affect the school district's ranking and land values. Overutilization will also increase the deterioration rate of the facilities and can also create more stress on students and teachers, causing parents and teachers to move elsewhere to find a better education system. A declining and unstable population base will affect the property taxes, which are considered the main revenue source for day-to-day operating and maintenance expenses. This budget dilemma cycle will continue as more schools are closed.

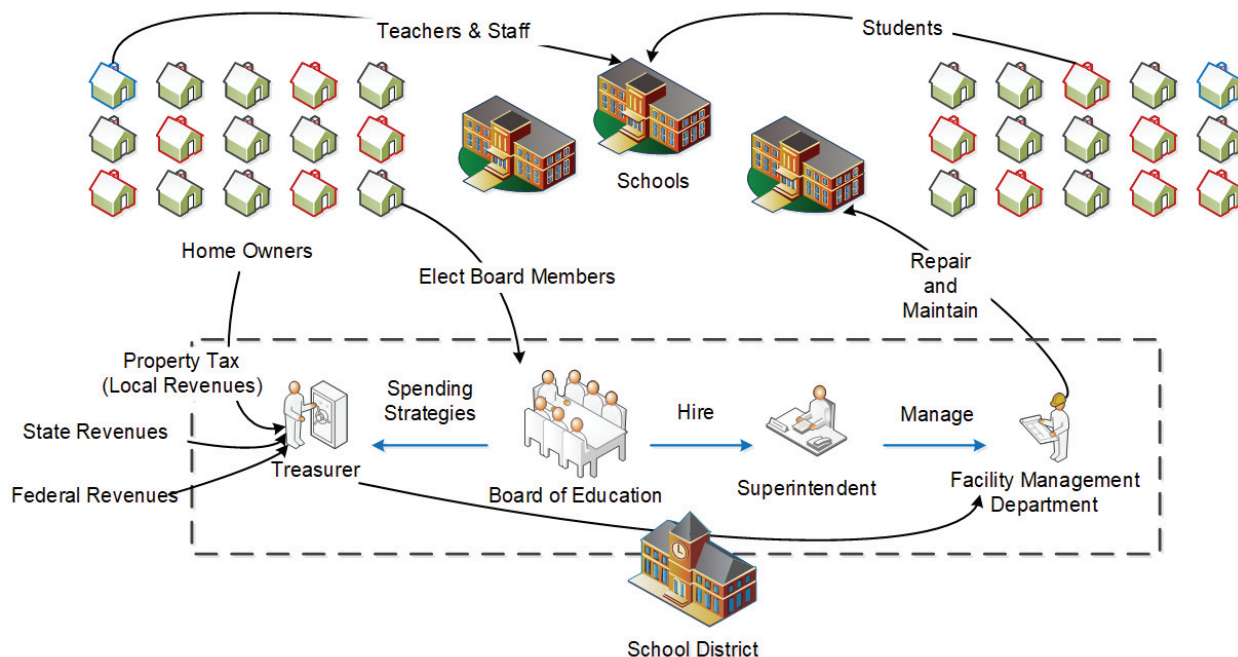

Figure 5.2 Public Education School Operating Budget Cycle

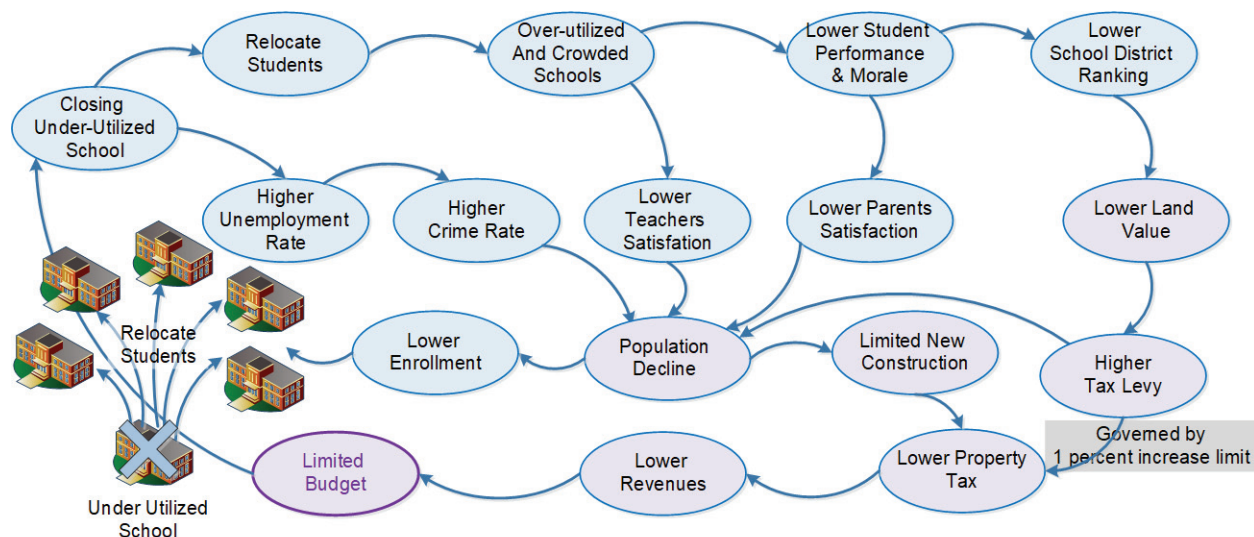

Figure 5.3 The Budget Dilemma of Public Education

As shown in Figure 5.4, the proposed strategic level model will mainly concentrate on the beta and gamma levels of the Lexicon table (Table 4.13) in the previous chapter. The model focuses on capturing and testing the effects of different budget allocation strategies (school district gamma level) on a school's overall academic achievement and school facilities condition (beta level).

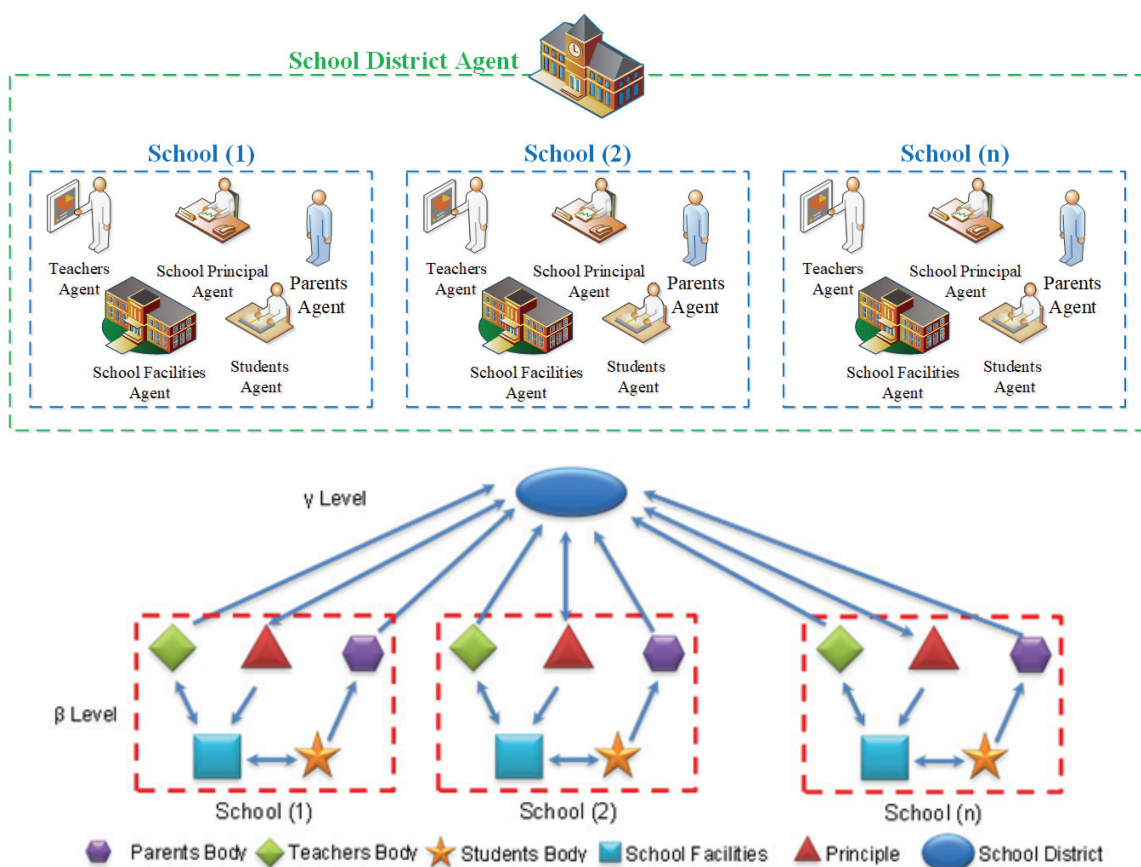

Figure 5.4 Strategic Model Boundaries

5.2.2 Abstraction Phase

The key stakeholders in our strategic level model include the students, teachers, parents, school principals, and school districts. The model's fundamental assumption is that the school administration operates and maintains the school's assets in good working condition to serve its users (students and teachers) according to their expectations. Unfortunately, there are limited funds for school districts to cover the needs of every school within the district. The model also assumes that there are mutual effects between the school's facilities and its occupants.

Agent based modeling (ABM) was selected to represent the complexity of a system where budget allocation strategies and their effects involve social, political, and economic aspects that easily can be modeled with the ABM approach.

5.2.2.1 Strategic Level Conceptual Model (Paper Model)

As mentioned earlier in the introduction, the U.S. education system has become a big news topic over the past decade because of its declining performance. The problem facing U.S. schools is not straightforward; there is no single factor that if it was fixed, would solve all the problems. Factors such as politics, tax rules, overcrowding, deteriorating facilities, budget constraints, and the existence of different stakeholders, each with a different perspective and objective, all contribute to the current situation. For example, students must deal with a school's rules, overcrowding, and hazardous building conditions every day, which can lead to poor performance, as well as they should, and put their future and health at risk. Teachers would like to maximize their performance and give their students a great foundation for a successful future. However, teachers also must deal with the rules, building conditions, staff, and parents. Parents would like the best possible future for their children and not have to worry about their health and safety while at school. Principals and administrators must provide the best service possible (safe buildings and good academic programs) within their limited funds to satisfy both the school district and the school users. Due to financial shortfalls in recent years, school budgets must be allocated in the order of what is needed and considered most important. Building maintenance is often seen as a low priority and therefore often delayed. Bypassing building maintenance has resulted in continuing deterioration of school buildings, which leads not only to the spending of more money to build

new schools in some cases, but also to hazardous situations for students and teachers alike. This thesis will show by means of the proposed ABM that building maintenance is not only important economically, but also plays a role in student academic achievement and morale.

The proposed model aims to demonstrate the effects of different strategies under which the budget can be allocated to a certain school for maintenance. The conceptual model is shown in Figure 5.5. More in-depth explanation of the stakeholders, their objectives, and interactions are provided in the following section.

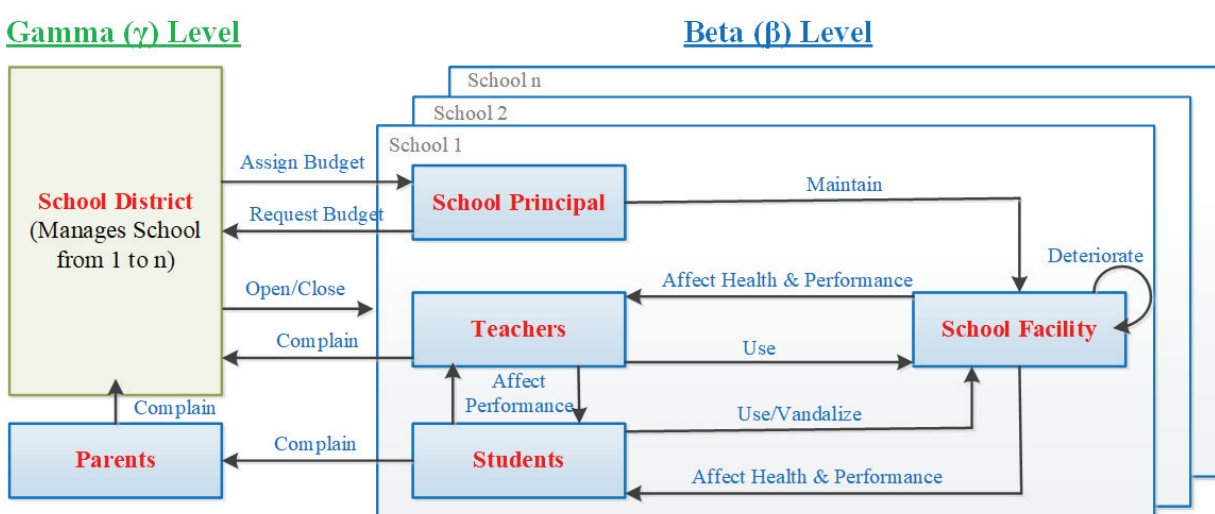

Figure 5.5 Strategic Level Conceptual Model

5.2.2.2 Agents Definitions and Interactions

The major stakeholders in the proposed model and their interrelations are presented in Figure 5.6. The proposed model consists of six agents: student, parent, teacher, principal, facilities, and school district, which are represented in the figure in the large gray boxes. The attributes of an agent can be static (rectangle shape), time dependent (trapezoid shape), and time and action-dependent (oval shape). Hexagon shapes represent an action or method that belongs to one of the agents. In general, attributes can be influenced by other attributes of the same agent along with interactions with other agents.

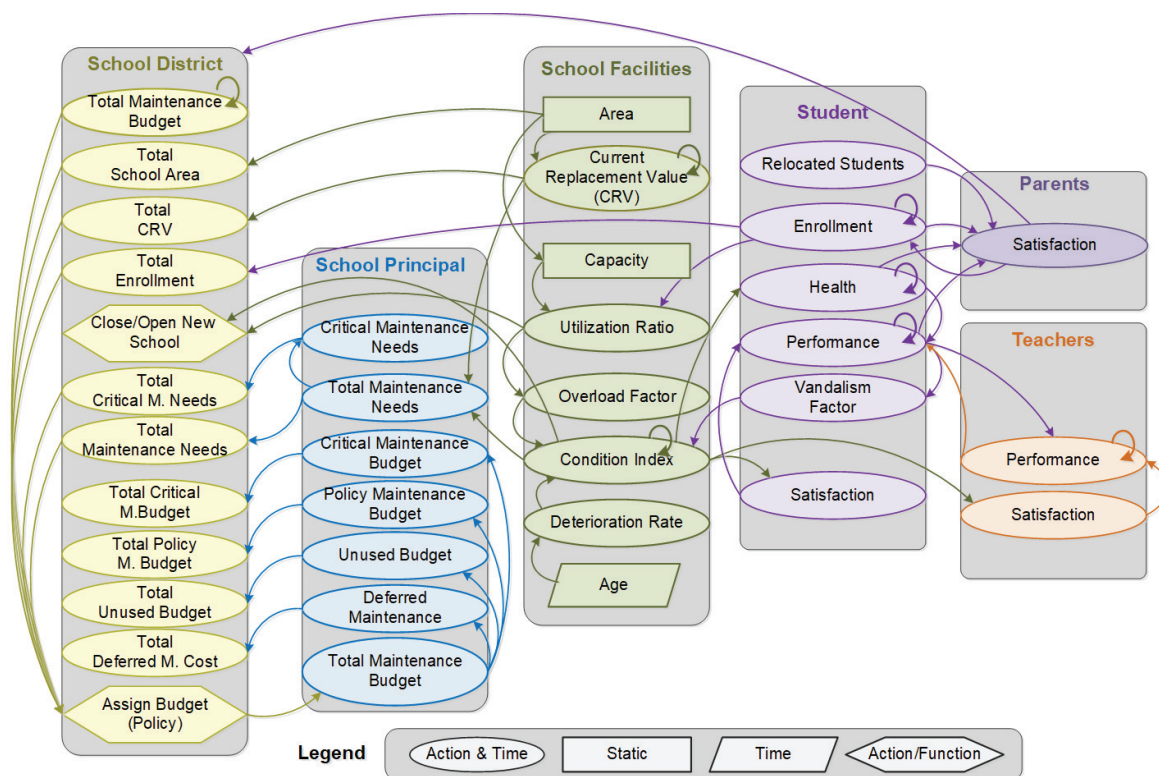

Figure 5.6 Agent Attributes and Interactions

Student Agent (Beta Level)

The student agent in the presented model represents the student body (not individual students). Their main objective is to improve their performance and to achieve goals, they need to be healthy and able to maintain a high level of satisfaction. Student satisfaction represents the satisfaction with the condition of the school facilities.

Another factor assumed by the model that could affect student performance is the teachers' performance. The model assumes that satisfied teachers can perform better and achieve better results with their students. On the other hand, unsatisfied students complain to their parents and may vandalize school property, which accelerates the deterioration process.

Parent Agent (Beta Level)

The parent agent is closely related to the student agent. It represents the parents of all the students in a single school. The parent agent's main objective is to improve their children's achievement and maintain their health. Parent satisfaction is a function of the student's performance and health and the ratio of relocated students to the school's enrollment. Unsatisfied parents can move to another school district, which may affect the local revenues for the school district.

Teacher Agent (Beta Level)

The teacher agent represents the population of all the teachers in a single school. Like students, teachers are directly impacted by the condition of the school facilities. The teacher agent's main objective is to maintain a high level of satisfaction to improve their performance, which in turn, leads to better student performance.

Principal Agent (Beta Level)

The main objective of the principal agent is to improve the physical condition of their school facilities and to provide a safe and healthy environment for its occupants. To achieve their objectives, the principal agent must be able to obtain funding that at least covers repairing critical maintenance needs such as fixing gas leaks or replacing a failed roof. The principal agent makes day-to-day decisions regarding school repair and maintenance priorities. These agents evaluate the school facilities' condition and requests the needed budget from the school district.

School Facilities Agent (Beta Level)

The condition of school facilities will change over time due to the normal wear and tear effect and the user consumption pattern. The school facilities agent represents the physical facilities as a whole, which includes all the encapsulated systems such as electricity, mechanical, structural, etc. In the model, the school buildings are assumed to deteriorate because of aging, overcrowding, and vandalism.

School District Agent (Gamma Level)

The members of the school district board of education and the superintendent play an important role in the school infrastructure decision-making process. Their actions influence the school buildings, principals, teachers, and students alike. The main objective of the school district agent is to make sure that the deterioration of the school buildings does not cause any damage to its users (students, teachers, etc.). In the model, the school district is responsible for giving the maintenance budget to the principals based on the available resources and the budget requests from each principal. They are also responsible for closing schools due to poor condition and/or underutilization to close the funding gap.

5.2.3 Implementation Phase

The implemented model's UML class diagram is shown in Figure 5.7, and the next few sections describe the model's implementation, starting with each agent's implementation details, then the code execution process, and ending with a case study for testing the proposed model along with the validation and verification process.

5.2.3.1 Agents Implementation & Dynamics

Agents are the main constituents of an ABM. A description of each agent and its dynamics are presented in this section.

Student Agent (Beta Level)

In the tactical level model, the student agent represents a single student in a single classroom. In the strategic level model, the student agent represents the student body for a single school. As shown in the UML diagram (Figure 5.7), the student agent's main attributes are as follows:

- Student satisfaction represents the student body's overall satisfaction level with respect to school facilities. It is a number between -1 and 1, which is independent of its previous value. Student satisfaction is evaluated using the human agent's perception evaluation model discussed in detail in Chapter 4. Equation 4.1 is rewritten as follows:

$$\text{Student Satisfaction} = (\alpha * CI') + ((1 - \alpha) * \Delta CI) \quad (5.1)$$

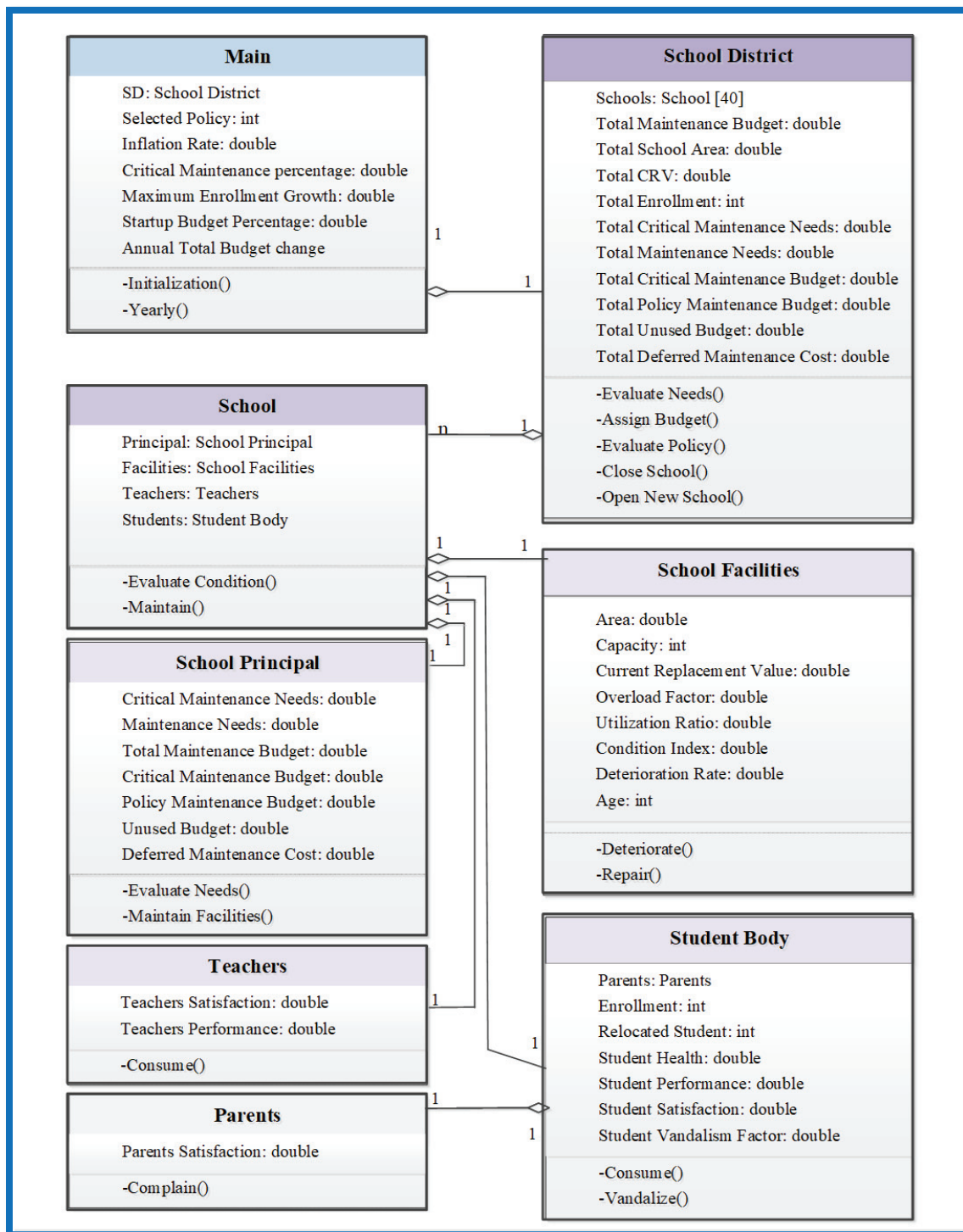

Figure 5.7 UML Class Diagram

Where:

α = weight factor (range: 0 to 1).

CI= school facility condition index.

$CI' = 2 CI_t - 1$, to convert CI_t from 0 to 1 range to -1 to 1 range.

$\Delta CI = CI_t - CI_{t-1}$ (the change in facility condition index – range:-1 to 1).

- Student health represents the student body's overall health and is a number between (0 to 1), assigned randomly during model initialization. Health assignment follows normal distribution with the following parameters: min= 0.5, max=0.9, mean=0.7, and standard deviation=0.1. Health is updated yearly (model step) based on the change (negative or positive) in the condition of school facilities. Student health is evaluated as follows:

$$\text{Student Health} = \text{Student Health} * (1 + \alpha * \Delta CI) \quad (5.2)$$

Where:

α = weight factor (range: 0 to 1).

$\Delta CI = CI_t - CI_{t-1}$ (the change in facility condition index – range:-1 to 1).

- Student performance is a number between 0 and 1 that represents the student body's overall performance. Performance is randomly assigned during simulation startup and updated each step throughout the function. Student performance is affected by the change in teacher performance and student health and satisfaction, which is calculated as follows:

$$SP_t = SP_{t-1} * (1 + (a_1 \Delta SS + a_2 \Delta SH + a_3 \Delta TP)) \quad (5.3)$$

Where:

a_1, a_2, a_3 = weight factors ($a_1 + a_2 + a_3 = 1$).

SP= Student performance.

$\Delta SS = SS_t - SS_{t-1}$: (change in student satisfaction. range: -1 to 1).

$\Delta SH = SH_t - SH_{t-1}$: (change in student health. range: -1 to 1).

$\Delta TP = TP_t - TP_{t-1}$: (change in teachers' performance: range: -1 to 1).

- Vandalism represents students' acts of vandalism due to stress caused by their performance. The model assumes that schools with an average overall performance of less than 65% commit vandalism toward their school facilities. The vandalism factor is evaluated as follows:

$$Vandalism\ Factor = \begin{cases} 0, & SP \geq 0.65 \\ \alpha(1 - SP), & SP < 0.65 \end{cases} \quad (5.4)$$

Where: α = weight factor (range: 0 to 1) and SP= student performance.

The student agent has two additional attributes: enrollment and relocated students. Enrollment represent the total number of student enrolled in a single school. The number is randomly assigned as a percentage of the school's maximum capacity, which is updated annually based on the change in parents' satisfaction.

Relocated students represents the number of students relocated from closing schools.

The student agent has two functions: consume and vandalize. The consume function updates the student's satisfaction, health, and performance. While the vandalize function evaluates how the vandalism factor is affecting the facility's condition.

Parents Agent (Beta Level)

The parents agent is located inside the student agent as shown in the UML diagram (Figure 5.7). The parents agent has a single attribute: the parents' satisfaction. Parents satisfaction is affected by the student health and performance level in addition to the number of relocated students added to the enrollment ratio.

$$Parents\ Satisfaction = \frac{Relocated}{Enrollment} * (\alpha * SH + (1 - \alpha) * SP) \quad (5.5)$$

Where:

α = weight factor (range: 0 to 1).

SH= Student health.

SP= Student performance.

The parents agent has a single function, the complaint function, whereby parents' satisfaction can be seen to affect population change and enrollment size.

Teacher Agent (Beta Level)

The teacher agent is located inside the school classroom as shown in the UML diagram (Figure 5.7). It represents the teachers of a single school and has two attributes: satisfaction and performance.

- Teacher satisfaction is a number between (-1) and (1), which is affected by the condition of the school facilities. Like student satisfaction, teacher satisfaction uses the human agent's perception evaluation model discussed in Chapter 4 and is calculated as follows:

$$\text{Teacher Satisfaction} = (\alpha * CI') + ((1 - \alpha) * \Delta CI) \quad (5.6)$$

Where:

α = weight factor (range: 0 to 1).

CI= school facility condition index.

$CI' = 2 CI_t - 1$, to convert CI_t from 0 to 1 range to -1 to 1 range.

$\Delta CI = CI_t - CI_{t-1}$ (the change in facility condition index – range:-1 to 1).

- Teacher performance is a number between 0 and 1, which represents teachers' overall performance. The performance value is randomly assigned during initialization and is updated each year through the teacher consume function. Teacher performance is affected by changes in their students' performance and their satisfaction level, which is calculated as follows:

$$TP_t = TP_{t-1} * (1 + (a_1 \Delta TS + a_2 \Delta SP)) \quad (5.7)$$

Where:

a_1, a_2 = weight factors ($a_1 + a_2 = 1$).

TP= Teacher performance.

$\Delta TS = TS_t - TS_{t-1}$: (change in teachers' satisfaction. range: -1 to 1).

$\Delta SP = SP_t - SP_{t-1}$: (change in students' performance. range: -1 to 1).

The teacher agent has a single function/method: consume, which updates teacher satisfaction and performance values.

School Facilities Agent (Beta Level)

The school facilities agent represents all the buildings and building systems of a single school.

It deteriorates with time and due to overutilization and vandalism acts. The school facilities have the following attributes:

- **Type:** The school type represents the grade level, which can be elementary, middle, or high school.
- **Area:** The school type represents the total gross area of a single school. The school area is assigned during simulation initialization and when a new school is constructed. The area is based on the national median and the low and high quartiles values from the 20th Annual School Construction Report (Abramson, 2015) as shown in Table 5.1.

Table 5.1 New Schools' Information Based on 20th Annual School Construction Report

Source: (Abramson,2015)		Elementary Schools	Middle School	High School
Building Size (Sq. Ft.)	National Medians	84,700	118,500	173,727
	Low Quartile	75,000	80,290	120,000
	High Quartile	103,000	150,000	267000
Sq. Ft/ Student	National Medians	188	173.4	180
Cost (\$/Sq. Ft.)	National Medians	211.55	242.96	235.29

- The maximum capacity is the maximum number of students the school was designed to serve. It is assigned during agent creation and is calculated by dividing the school area by the recommended area per student for each school type.
- The utilization factor (UF) is the school enrollment divided by its maximum capacity. UF is an indicator of how crowded the school is.
- The current replacement value (CRV) is the cost of reproducing a similar building using the current market prices. The initial value was taken from the Annual School Construction Report and is shown in Table 5.1 (Abramson, 2015), which is updated annually using the inflation rate set by the user.

- School age is randomly assigned during initialization and is a time-dependent variable that increases annually.
- The condition index (CI) is a number between 0 and 100% that represents the overall condition of the school facilities and is based on the ratio of (1-deficiencies cost) to the current replacement value (CRV). CI is used to compare the relative condition of a group of buildings. CI interpretation is shown in Table 5.2 and Figure 5.8. During initialization, the CI assignment was based on the Austin Independent School District facilities master plan (2011) and its facility condition index (FCI) information. FCI is the complement of CI (FCI= 1-CI) and is highly correlated with the school age (0.728) as shown in Figure 5.9. Therefore, the CI was initialized randomly using the results of following equation as the mean value:

$$CI_{t_0} = 1 - 0.303 * Age^{0.5778} \quad (5.8)$$

Table 5.2 Condition Index (CI) Interpretation

CI	Condition
95% to 100%	Best
90% to 95%	Good
80% to 90%	Average
70% to 80	Below Average
50% to 70%	Poor
35% to 50%	Very Poor
Below 35%	Replacement

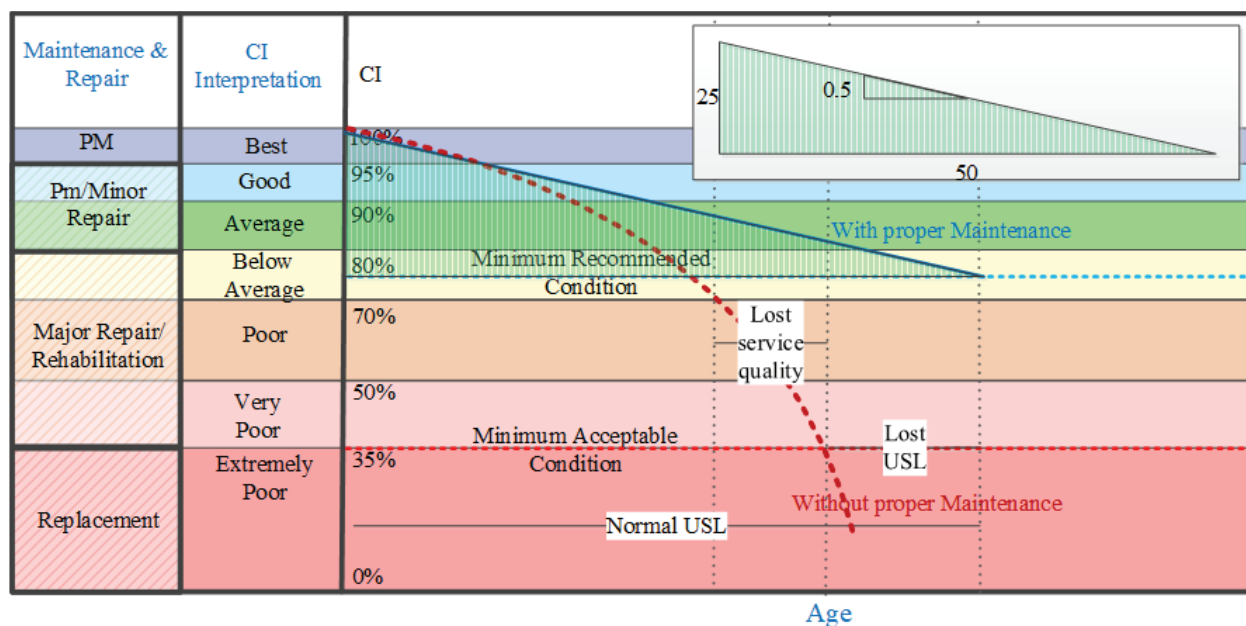

Figure 5.8 Facility Deterioration Curve

The CI changes with time and from overcrowding and vandalism based on the following equation:

$$CI_t = CI_{t-1} * (1 - DR) * OLF * (1 - VF) \quad (5.9)$$

Where: CI = condition index.

DR = wear and tear deterioration rate, assumed to be between 2.5 and 4.5% annually.

OLF = overload factor (range 0.9 to 1).

VF= vandalism factor.

The value for the deterioration rate was assumed to be between 2.5 and 4.5% of the CRV. This assumption was based on building industry best practice values. According to Filardo (2016), two percent of the CRV is sufficient to maintain school facilities in good condition over a 50-year period provided the recommended preventive maintenance is implemented. As shown in Figure 5.8, the CI value (shown as the blue line) declines 0.5% annually over the course of 50 years to reach 75% at the end of the useful service life of the building. An additional 2% (of CRV) is needed annually for life cycle periodic renewals such as

replacing boilers, windows, and roofs. Summing these values yielded the maximum deterioration value used in the model ($2\%+0.5\%+ 2\%=4.5\%$).

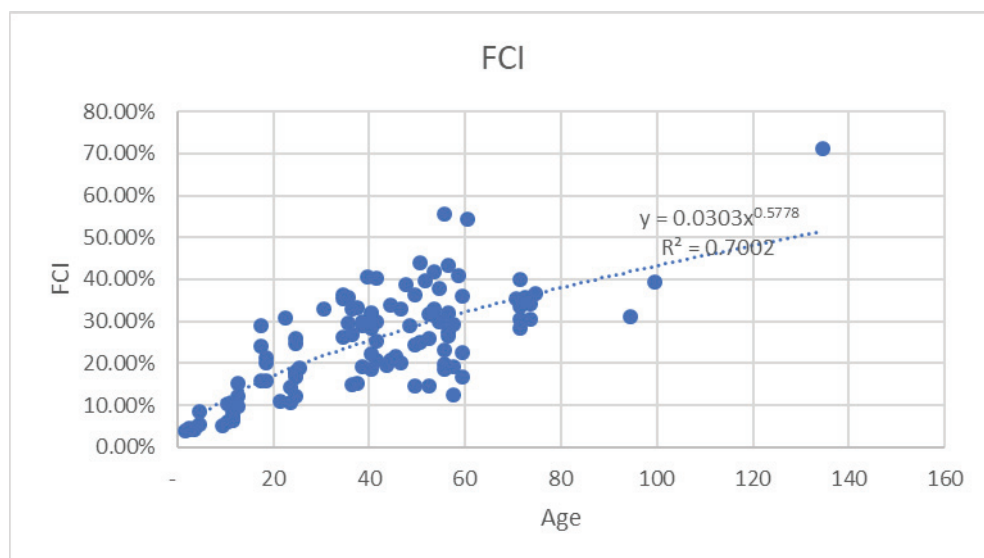

Figure 5.9 Austin Independent School District FCI vs. Age Relationship

The CI also changed and increased with the funding for maintenance needs through the repair function.

$$CI_{t,\text{after repair}} = CI_{t,\text{before repair}} + \frac{\text{Maintenance Budget}}{\text{Current Replacement Value}} \quad (5.10)$$

- The overload factor ranges from 0.9 to 1 and lowers the school condition (CI) based on the degree of overutilization as shown in Figure 5.10.

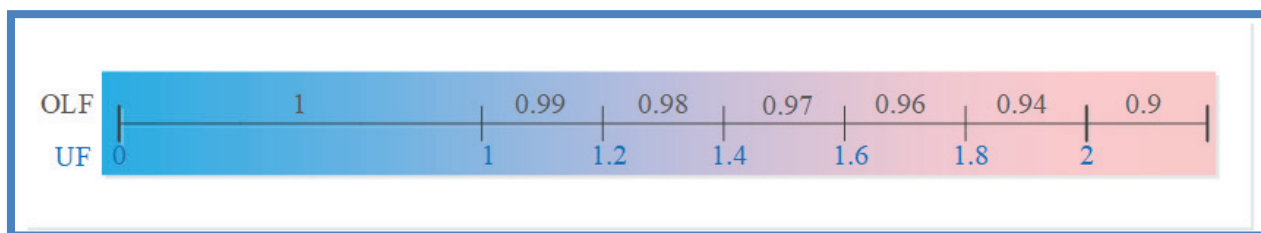

Figure 5.10 OLF and UF Relationship

School Principal Agent (Beta Level)

The school principal agent represents a single school's management and is responsible for evaluating the needed maintenance budget to keep the school safe and in good condition to fulfill its mission.

The school principal attributes are divided into two categories: maintenance needs and maintenance budget. Maintenance needs can be divided further to total maintenance needs, critical maintenance needs, and deferred needs.

- The school total maintenance needs (STMN) represent the amount of funding needed to improve the overall physical condition of the school facilities ($CI=0.95$). It is calculated as follows:

$$STMN = \begin{cases} (0.95 - CI) * CRV, & CI < 0.95 \\ 0, & CI \geq 0.95 \end{cases} \quad (5.11)$$

Where:

STMN = School total maintenance needs.

CRV = Current replacement value.

- Critical maintenance needs (CrMN) represent one-third of priority 1, which need to be repaired immediately.

Some of the school facilities assessment reports, which were discussed earlier in Chapters 2 and 3 use the Magellan assessment and project planning system (MAPPS) standardized report format. All of the MAPPS reports contain a table of the five priorities divided into the different building systems. As shown in Table 5.3, the data were collected for five school districts: Saint Paul, U-4, Baltimore, Jeffco, and Austin, which totaled 575 schools. Tables 5.4 and 5.5 show the summary results for priorities (1) to (5) maintenance needs distribution per building system as a percentage and as (USD per sq. ft.). Priority 1 is responsible for 6% of the total maintenance needs; therefore, the school principal tries to pressure the school district to provide at least one-third of it or 2% of the total maintenance needs.

- The deferred maintenance needs are the cost of the remaining needed funding that was not covered by the allocated budget. It is calculated as follows:

$$\text{Deferred Cost} = \text{Total Needs} - \text{allocated budget} \quad (5.12)$$

Table 5.3 Available Facility Assessment Reports Created By MAPPS System

School district	State	City	Schools Count	Total Area (sq ft)
St. Paul Public School District	MN	Saint Paul	73	7,317,170
School District U-46 - Elgin	Illinois	Elgin	65	5,837,763
Baltimore City Public Schools-City	Maryland	Baltimore	163	17,482,340
Jeffco Public Schools	Colorado	Jeffco	148	11,702,064
Austin Independent School District	Texas	Austin	126	12,307,255
			575	54,646,592

The second attributes category includes the budget-related attributes:

- The total available budget is the total budget assigned by the school district based on the selected allocation policy and includes the critical budget, the policy budget, and the unused budget.
- The critical budget is assigned by the school district. Most of the time the critical budget is equal to the critical maintenance needs, but it could be less than the needed budget in the case of extremely low revenues.
- The policy budget is the amount of money assigned by the school district based on the selected budget allocation strategies, which will be discussed in the next section.
- The expenditure is the sum of the critical and policy budgets.
- The unused budget is the amount of money allocated by the school district based on certain criteria but exceeds the total maintenance needs of schools. Normally, this attribute will be equal to zero, but with certain allocation policies or with a huge school district total budget to begin with, this value could result in a number other than zero.

The school principal agent has two responsibilities: evaluate the needs and maintain the facilities.

To evaluate the needs, the values of the total maintenance needs and critical needs are calculated.

The maintain function divides the allocated budget over the critical, policy, and unused budgets and evaluates the remaining deferred maintenance cost.

Table 5.4 Priorities 1 to 5 – Maintenance Needs per Building System as Percentage

	Pr1	Pr2	Pr3	Pr4	Pr5	Overall
Site	1.36%	0.52%	8.94%	15.31	13.88	7.62%
Roofing	25.43	5.04%	3.21%	1.03%	0.02%	4.32%
Exterior	0.45%	4.10%	2.78%	1.66%	1.99%	2.75%
Structure	2.37%	0.82%	1.09%	0.09%	0.14%	0.76%
Interior	0.39%	2.11%	16.97	18.69	10.27	10.68%
HVAC	6.99%	73.94	21.64	7.33%	2.57%	32.54%
Plumbing	9.40%	1.89%	9.13%	15.65	3.26%	7.38%
Electrical	4.39%	4.84%	12.31	4.09%	6.51%	7.07%
Technology	0.70%	1.18%	9.52%	15.56	7.21%	7.20%
Fire and Safety	35.05	2.13%	3.52%	0.11%	5.07%	4.48%
Stairs & Elevators	0.46%	0.69%	3.24%	2.22%	0.00%	1.65%
Specialties	0.87%	0.08%	7.65%	18.24	17.66	8.11%
Other	12.12	2.67%	0.00%	0.02%	31.42	5.43%
%Pr. of Total	6.04	32.41	29.51	19.86	12.19	100.00

Table 5.5 Priorities 1 to 5 – Maintenance Needs per Building Systems (USD per sq. ft.)

2018 \$ / sq.ft.	Pr1	Pr2	Pr3	Pr4	Pr5	Overall
Site	0.06	0.12	1.94	2.23	1.24	5.59
Roofing	1.13	1.20	0.69	0.15	0.00	3.17
Exterior	0.02	0.98	0.60	0.24	0.18	2.02
Structure	0.11	0.19	0.24	0.01	0.01	0.56
Interior	0.02	0.50	3.68	2.72	0.92	7.84
HVAC	0.31	17.60	4.69	1.07	0.23	23.89
Plumbing	0.42	0.45	1.98	2.28	0.29	5.42
Electrical	0.19	1.15	2.67	0.60	0.58	5.19
Technology	0.03	0.28	2.06	2.27	0.65	5.29
Fire and Safety	1.55	0.51	0.76	0.02	0.45	3.29
Stairs & Elevators	0.02	0.16	0.70	0.32	0.00	1.21
Specialties	0.04	0.02	1.66	2.66	1.58	5.96
Other	0.54	0.64	0.00	0.00	2.81	3.99
\$USD / sq.ft.	4.44	23.80	21.67	14.58	8.95	73.43

School District Agent (Gamma Level)

The school district (SD) agent represents the higher-level management for the group of schools. The school district board of education is responsible for allocating the needed maintenance budget among the schools within the district. The school district's top priority is to cover the critical maintenance needs to prevent any catastrophic failure and to select the best and optimal strategy for allocating the rest of the budget.

The school district agent has the power to close underutilized schools or schools in extremely poor and unsafe conditions as a part of their strategy to optimize the available funding. Closing schools will result in savings in the operating budget, especially when new construction is funded from the capital outlay budget, which is financed by bonds and a separate account not affected by the operating budget.

Like the principal agent attributes, the school district agent attributes can be divided into maintenance needs and maintenance budget.

School district maintenance needs are divided into:

- Total maintenance needs (TMN) is the summation of the maintenance needs for all schools.

$$TMN = \sum_1^n \text{ (School total maintenance needs)} \quad (5.13)$$

- Total critical maintenance needs (TCrMN) is the summation of all critical maintenance needs for all schools.

$$TCrMN = \sum_1^n \text{ (School critical maintenance needs)} \quad (5.14)$$

- Total deferred maintenance needs (TDMN) is the summation of deferred maintenance for all school and it is the remaining maintenance needs after doing current year maintenance.

$$TDMN = \sum_1^n \text{ (School Deferred maintenance needs)} \quad (5.15)$$

- Total maintenance budget (TMB) is the total amount of money allocated for school district maintenance. The recommended percentage by building industry best practices is 2% for maintenance and another 2% for life cycle renewables as well as 1% to make up for delayed deferred maintenance needs (Filardo, 2016). In the proposed model, the user can enter the desired budget factor to test (from 1 to 10 % of Total CRV). The total maintenance budget amount is updated at the end of each year to reflect the inflation rate and changes in land values affected by student performance and district ranking.

$$TMB_t = \begin{cases} BF * CRV, & \text{at time} = 0 \\ TMB_{t-1} * (1 + \text{inflation rate}), & \Delta SP \geq 0 \\ TMB_{t-1} * (1 + (\alpha * \text{inflation rate} + (1 - \alpha) * SP)), & \Delta SP < 0 \end{cases} \quad (5.16)$$

Where:

α = weight factor (range: 0 to 1)

TMB = Total maintenance budget.

BF= Budget factor (recommended 2% to 5%)

CRV=Current replacement value.

SP= Average student performance.

- The total critical maintenance budget (TCrMB) is equal to the total critical maintenance needs (TCrMN). Normally, the total critical budget should be equal to the total critical maintenance needs, but it could be equal to the total maintenance budget in case of extreme budget cuts as shown in case (1) of Figure 5.11.

$$TCrMB = \begin{cases} TCrMN, & TCrMN < TMB \\ TMB, & TCrMN \geq TMB \end{cases} \quad (5.17)$$

Where:

TCrMB=Total critical maintenance budget.

TCrMN=Total critical maintenance needs.

TMB = Total maintenance budget.

- The available maintenance budget (AMB) is the remaining maintenance budget after deducting the total critical maintenance budget. AMB will be divided between schools based on the selected policy (area, enrollment, CI, performance, parents satisfaction, ...etc.)

$$AMB = TMB - TCrMB \quad (5.18)$$

Where

AMB=Available maintenance budget.

TMB=Total maintenance budget.

TCrMB= Total critical maintenance budget.

- The policy maintenance budget (PMB) is the sum of the policy budget for all the schools.

$$PMB = \sum_1^n (\text{School policy maintenance budget}) \quad (5.19)$$

- The total expenditure (TE) is the sum of the total critical maintenance budget and the total policy maintenance budget.
- The total unused budget (TUB) is the total unused maintenance budget for all the schools.

$$TUB = \sum_1^n (\text{School unused maintenance budget}) \quad (5.20)$$

The school district agent has five responsibilities:

- Evaluate the needs by calculating the total and critical needs for all the schools in the district.
- Assign budgets: Based on the selected budget allocation policy, this function evaluates the distribution ratio for each school. The ratio is then multiplied by the total available budget after deducting the critical needs budget. The result is assigned to each school principal to use for maintaining his school facilities.
- Evaluate policies: This function evaluates the district overall average values for facilities' condition, student performance, and parents' satisfaction, as well as summing the total critical policy, unused, and deferred needs budgets and costs.

- Close schools: The model assumes that SD can only close one school per year (equivalent to 2.5%). Students of the closed school are relocated to available schools with the same grade levels.
- Open new schools: The same goes for new construction in that the model limits opening new schools to one per year. Only 25% of closed schools are replaced.

The school district faces big challenges with how to divide the limited resources among the schools in the district. A portion of the total maintenance budget amount is allocated to critical maintenance, which is the amount of money needed for urgent maintenance tasks that affect users' safety and health. Such tasks can include fixing gas leaks or replacing unsafe electrical fixtures. The remaining portion is divided among the schools according to one of the following allocation policies:

1. School area to total district area in square feet.
2. School enrollment to total district enrollment.
3. School CI value, giving higher priority to schools in the worst conditions.
4. School CI value, giving higher priority to schools in the best condition.
5. Parents' satisfaction, giving higher priority to schools with low parents' satisfaction level.
6. Average student performance value, giving higher priority to schools with lower average performance.
7. Average student performance value, giving higher priority to schools with higher average performance.
8. Requested total maintenance budget to the district total maintenance needs.
9. Equal share, where each school gets the same amount despite its enrollment, age, size, or condition.

Figure 5.11 summarizes the possible cases for the allocated budget amount. In the first case, the school district has an extremely limited budget that will not even cover the critical maintenance needs for the schools. In that case, the total maintenance budget covers only part of the critical maintenance needs and the rest of the needs convert to deferred needs as shows in the second part of Figure 5.11.

In the second case, the assigned budget covers all the critical needs, but not all of the maintenance needs. In that case and like case (1), the remaining needs are considered deferred needs and are delayed for the coming years. The third case is like the second case, but the amount allocated by the policy covers all the maintenance needs. The last case is rare, and it can happen if the assigned budget is more than the total maintenance needs of the school. In that case, the excess money is considered as unused maintenance budget.

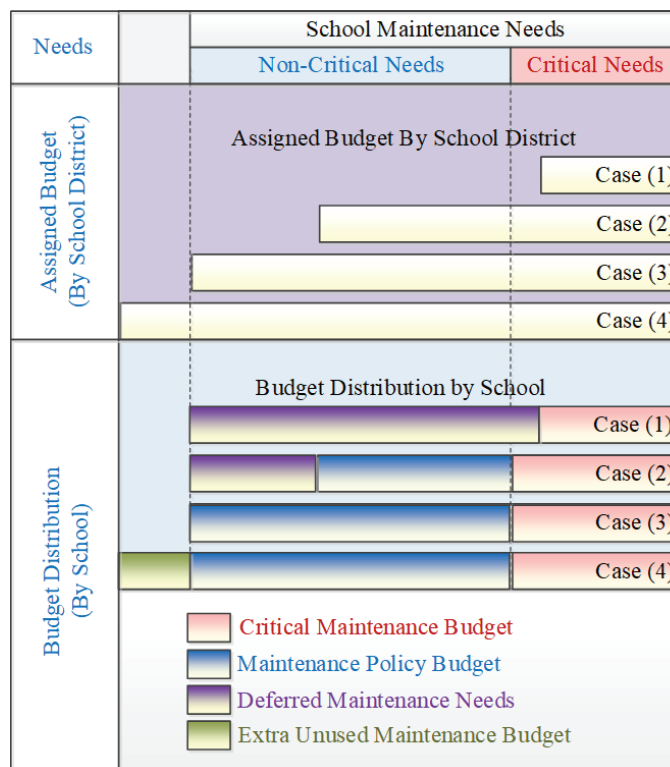

Figure 5.11 Budget Allocation Possible Scenarios

5.2.3.2 Model Execution and Simulation Case Study

The proposed model was implemented in AnyLogic 7.1.2 simulation software. The simulation focused on a single school district managing 40 schools over a 30-year time span. The model execution sequence is shown in Figure 5.12. The driving force for the simulation is time, where the time step represents one year. When the time counter changes, the schools age increases, and the overall condition deteriorates, which lowers the CI of the school facilities. The deteriorated facilities will reduce teachers' satisfaction and affect their ability to deliver information to students.

Similarly, students' health and satisfaction will be affected by the deteriorated facilities and the associated health hazards, which lead to lower performance and higher acts of vandalism. Lower student performance and health in addition to crowded schools will increase parents' dissatisfaction as well. As a result, school enrollment and local revenues will decrease.

The school principal agent uses the CI value to evaluate the regular and critical maintenance needs of the school and requests the needed funding from the school district. The district assigns budgets based on the selected maintenance budget allocation policy after covering the critical needs of all the schools. Consequently, the CI for each school is updated to reflect the percentage of the maintenance budget allocated to that school. The school district evaluates the results of the policy and decides to close or open new schools based on the enrollment size and school condition. The time counter is updated, and the same process is repeated over the tested period.

As shown in Figure 5.13, the user interface startup window can provide school district decision-makers with the option to test the effect of different budget allocation scenarios as well as select the budget factor for evaluating the startup total maintenance budget. Also, the input interface gives the user the freedom to modify the inflation rate and the critical maintenance percentage.

Figures 5.14 through 5.24 show an example of the model execution and comparison between the results of different budget allocation policies on the school district level (gamma level) and single school level (beta level). The nine different runs in figures 5.15 to 5.18 correspond to the different policies shown in 5.13, where run (0) for example correspond to enrolment size policy and run (1) correspond to the policy based on school area and so on.

The results and plots show the effects of different budget allocation policies on school district average performance, average facilities condition, total enrollment, and the total maintenance budget annual change. At the beta level, different policies produce different effects. For example, the enrollment policy may work best for schools with higher enrollment, the area policy may work best for schools with the bigger areas, etc. On the other hand, at the gamma level, all the policies have nearly the same effect when the budget factor is below 2; but with a higher budget factor, differences were found in the results between the tested policies.

Running the model for more than 30 years with a limited maintenance budget resulted in closing the most schools and relocated the students to the limited available schools, which will increase student enrollment in already overcrowded schools. Since the school system is facing budget cuts and increasing the budget may be unaffordable (at least for the time being), unconventional solutions may be needed in which the public and private sector form a partnership (PPP). Other solutions, such as combining e-learning with regular classes, also may be considered.

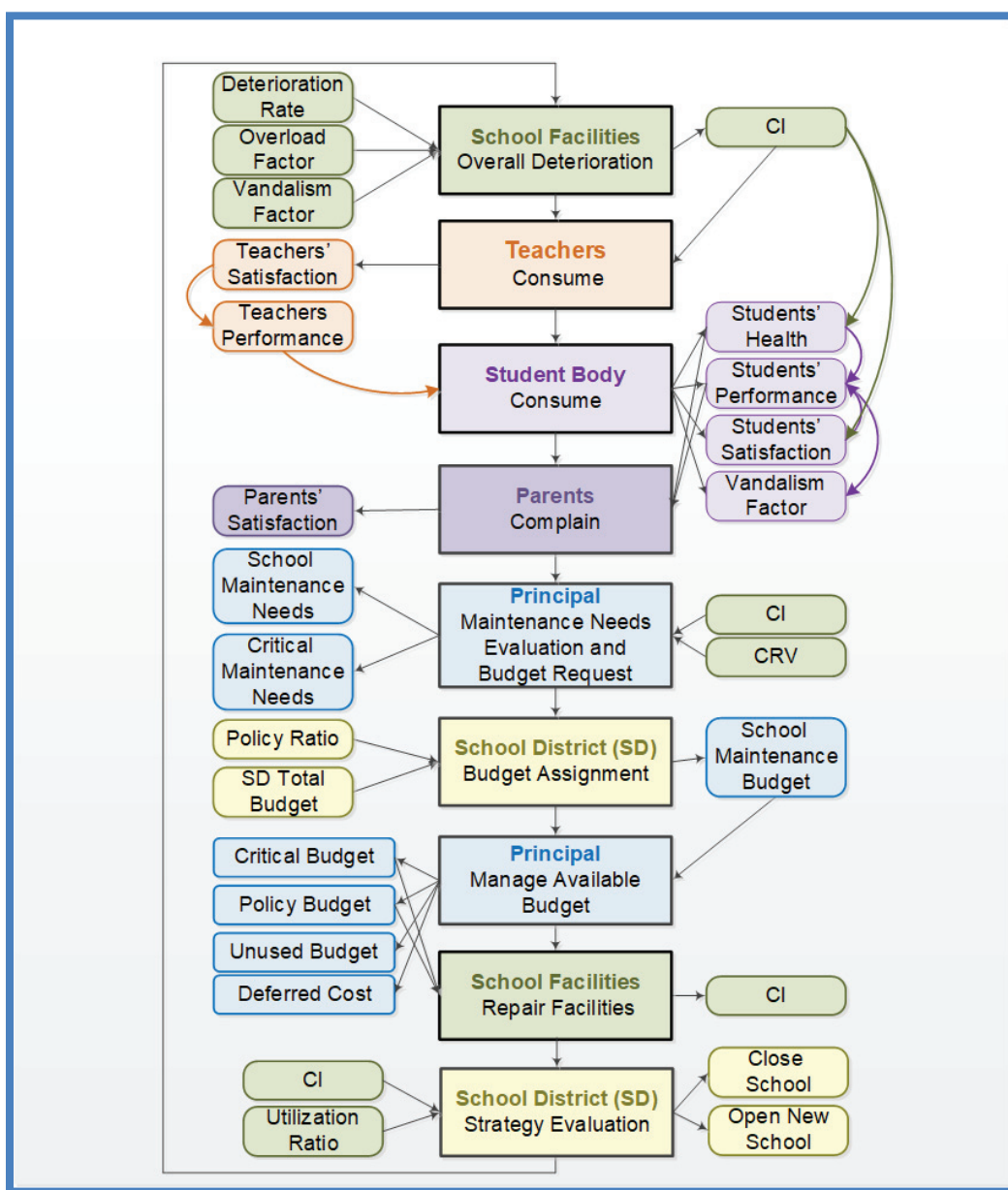

Figure 5.12 Strategic Level Agent-Based Model Simulation Process

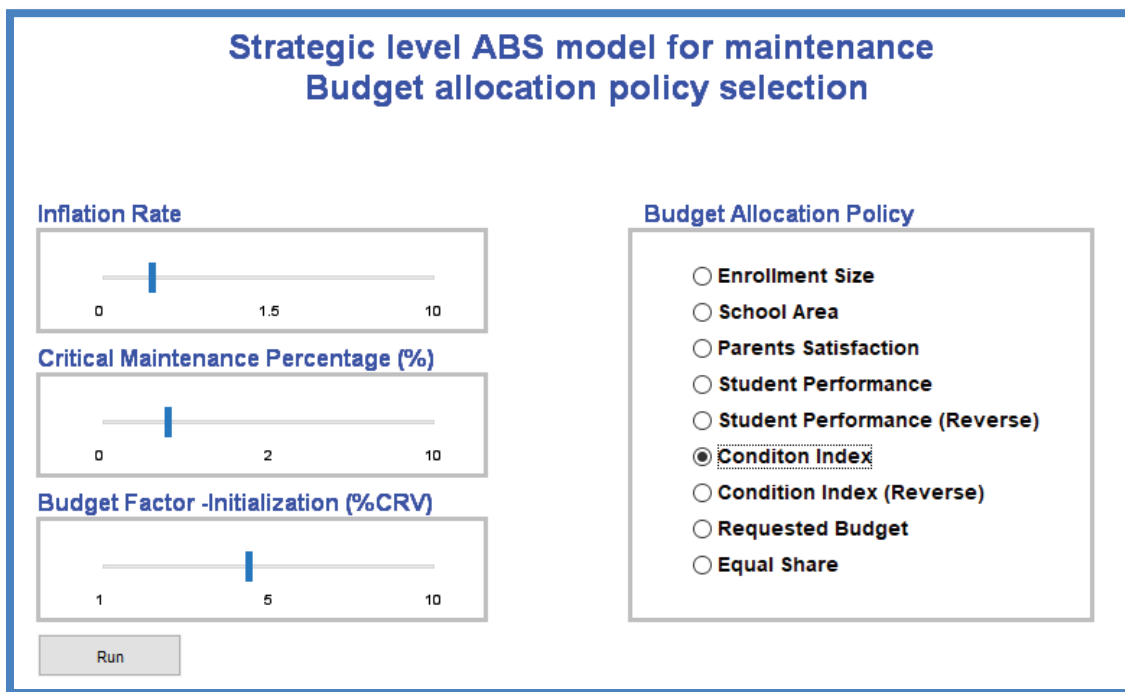

Figure 5.13 Input User Interface

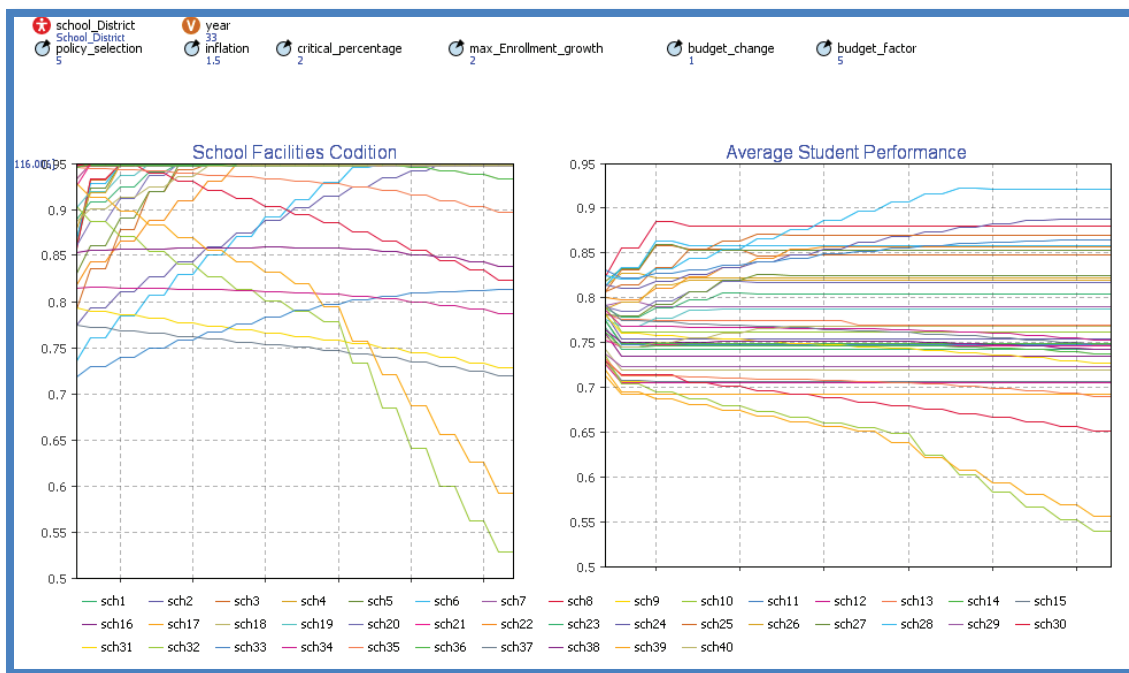

Figure 5.14 Sample Results - Budget Factor = 5

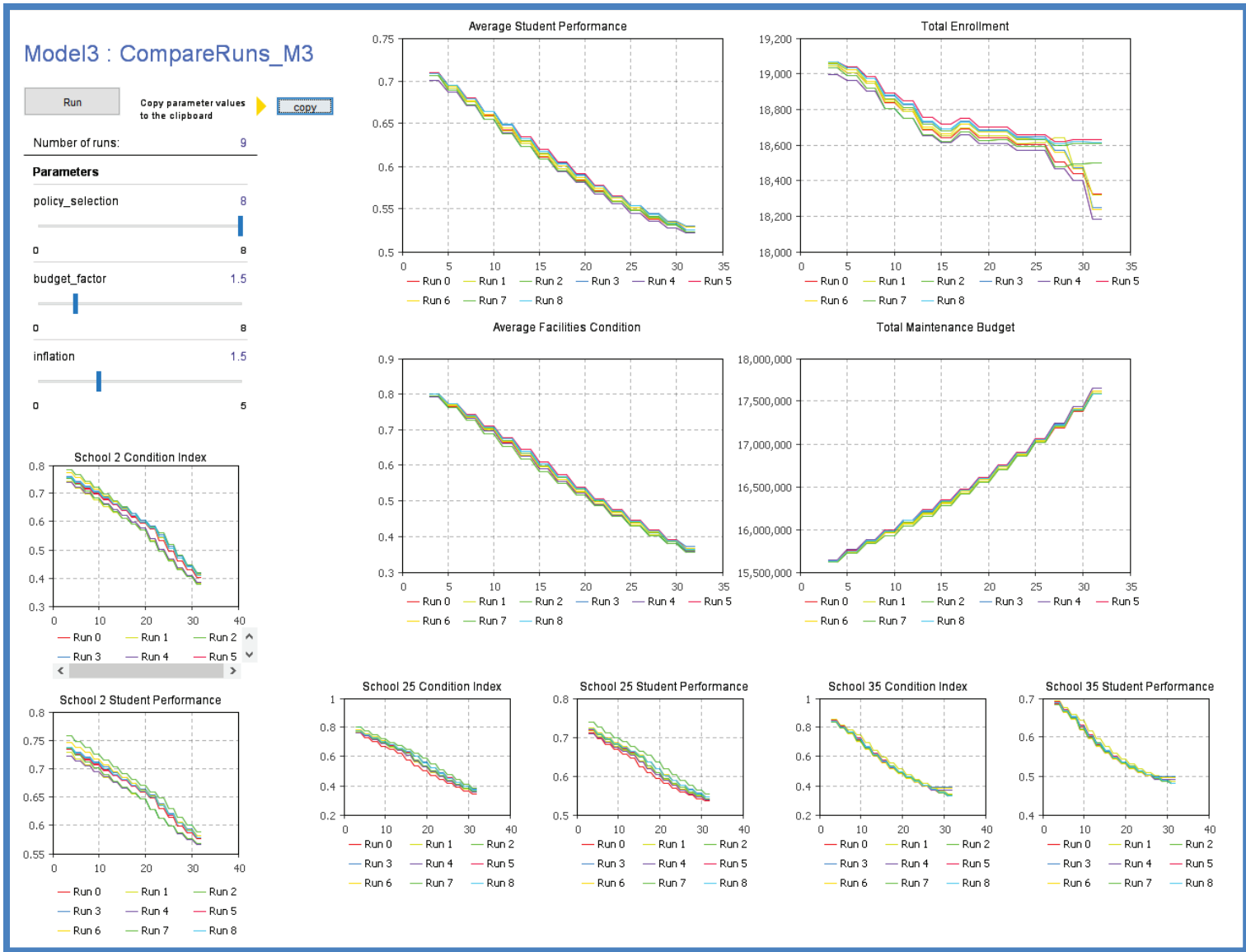

Figure 5.15 Sample Results - Policy Comparison - Budget Factor = 1.5

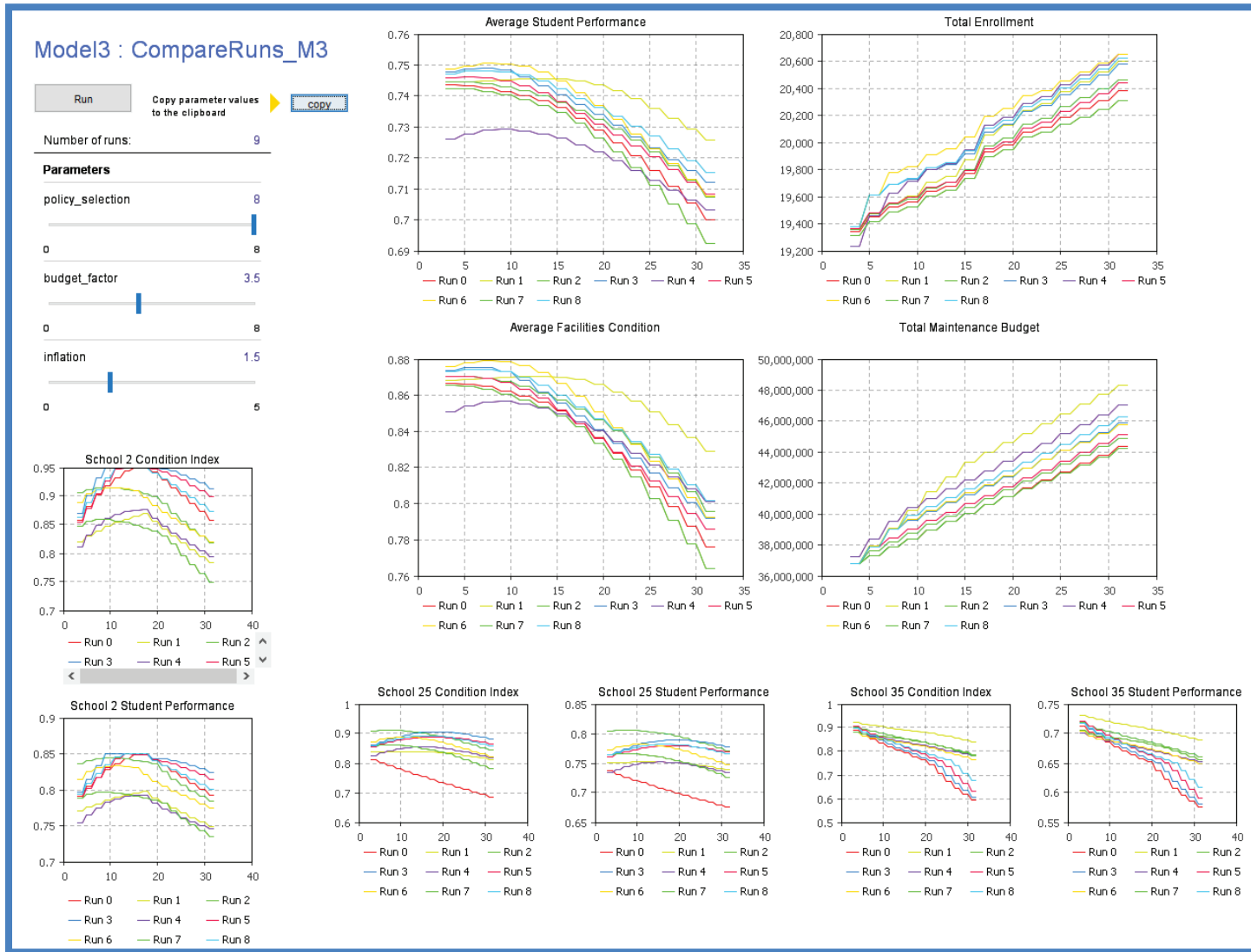

Figure 5.16 Sample Results - Policy Comparison - Budget Factor = 3.5

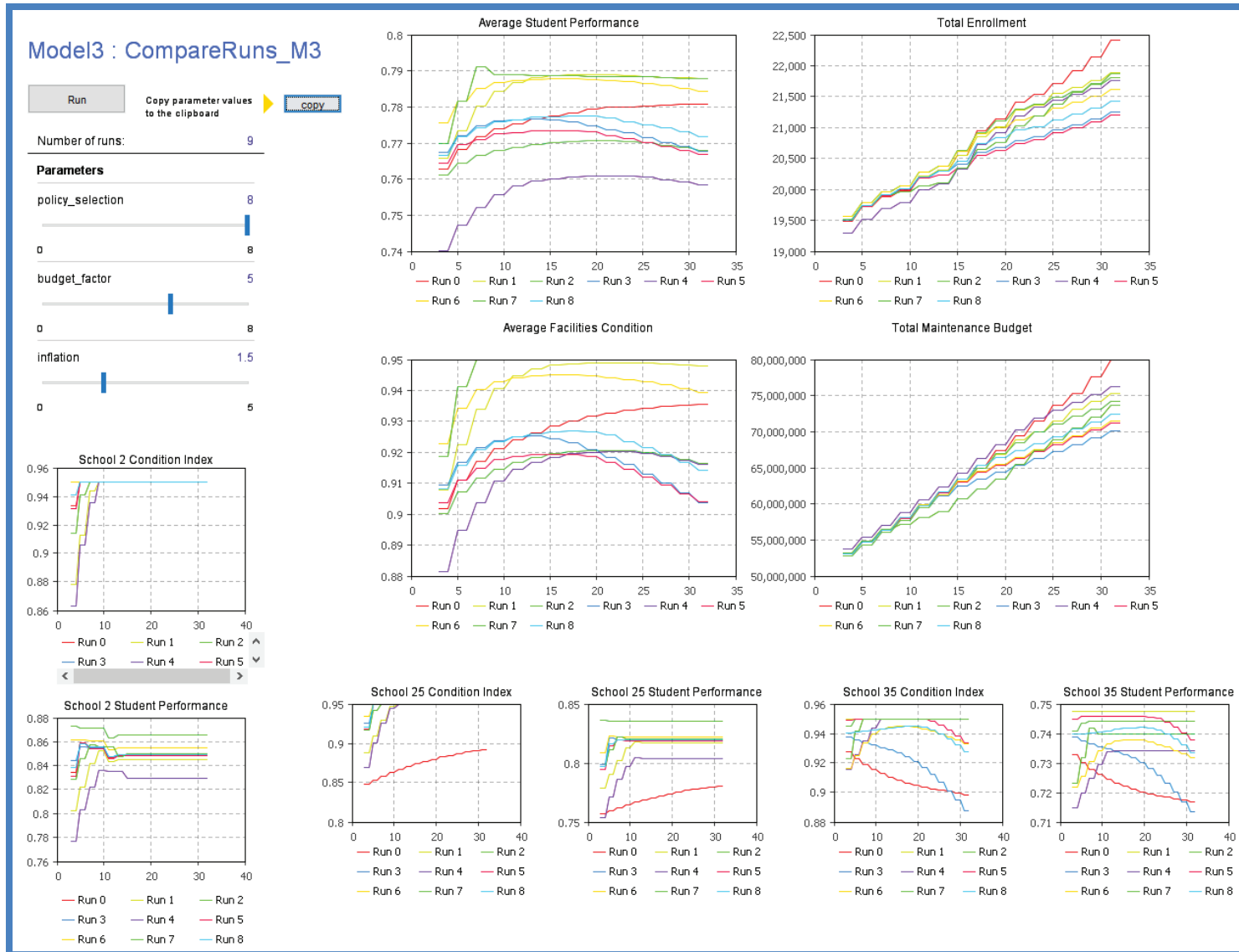

Figure 5.17 Sample Results - Policy Comparison - Budget Factor = 5

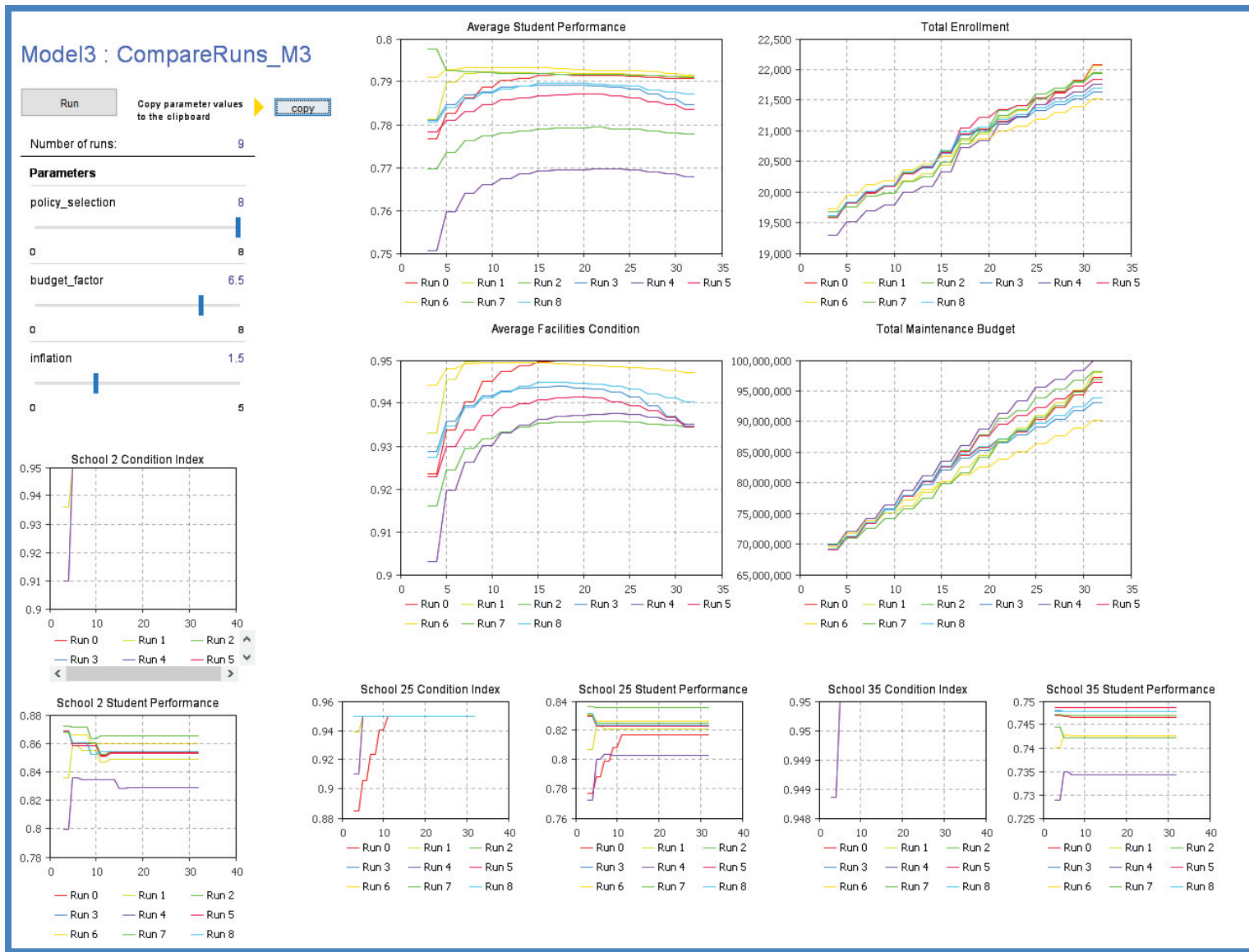

Figure 5.18 Sample Results - Policy Comparison - Budget Factor = 6.5

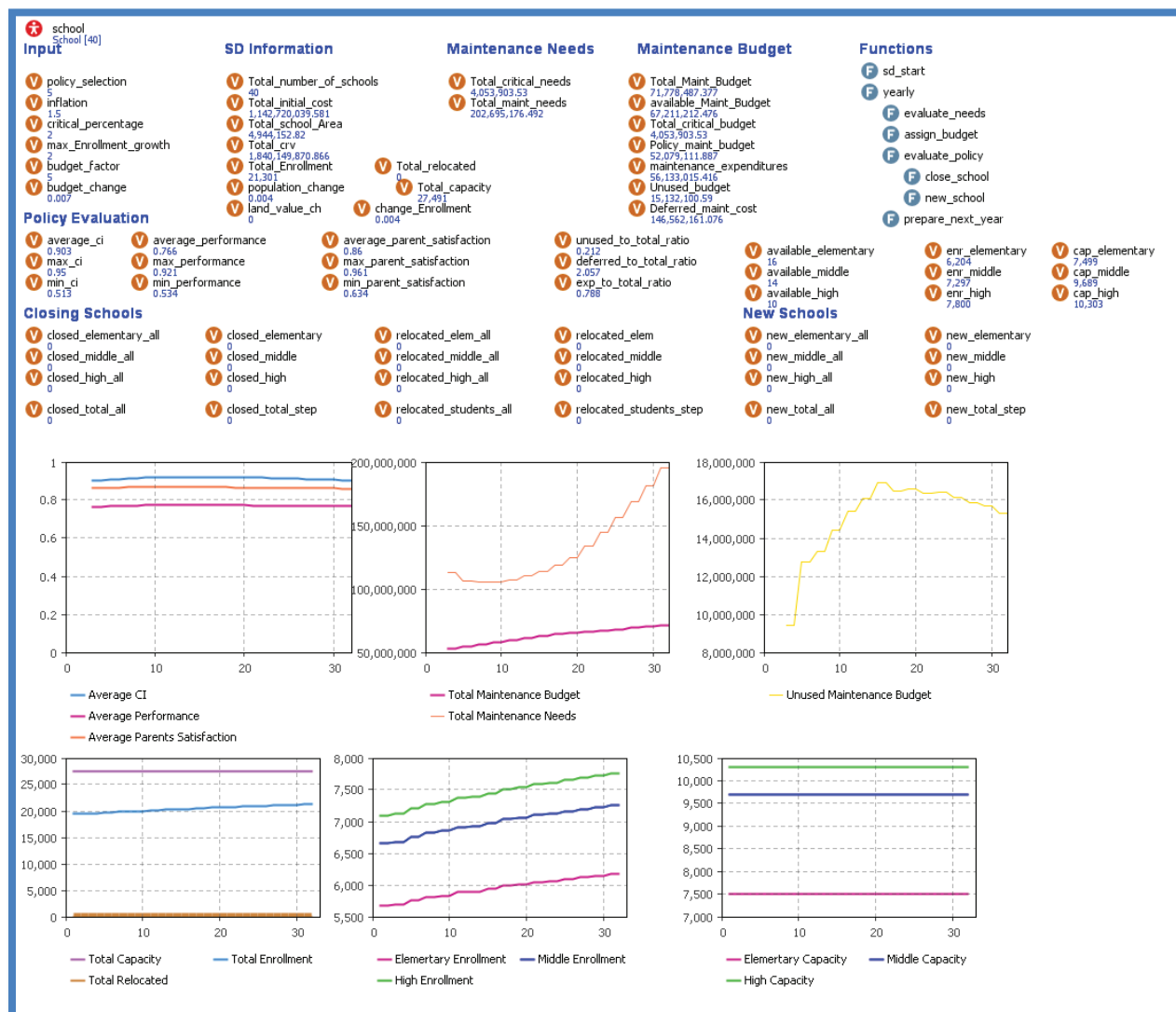

Figure 5.19 Sample Results - School District - Budget Factor = 5

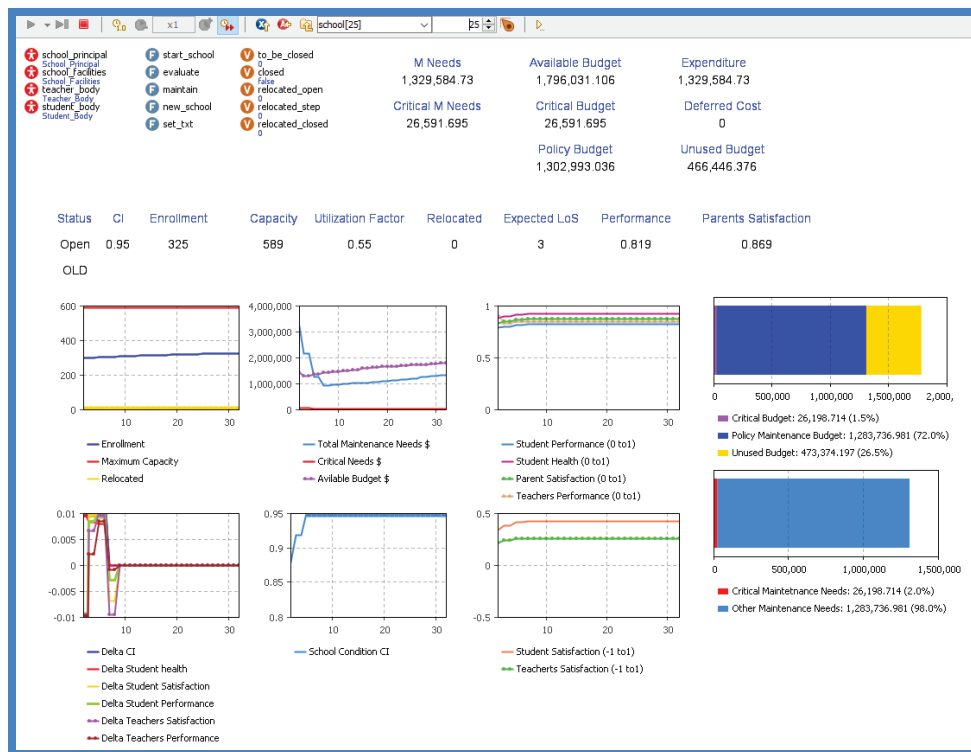

Figure 5.20 Sample Results - School 25 - Budget Factor = 5

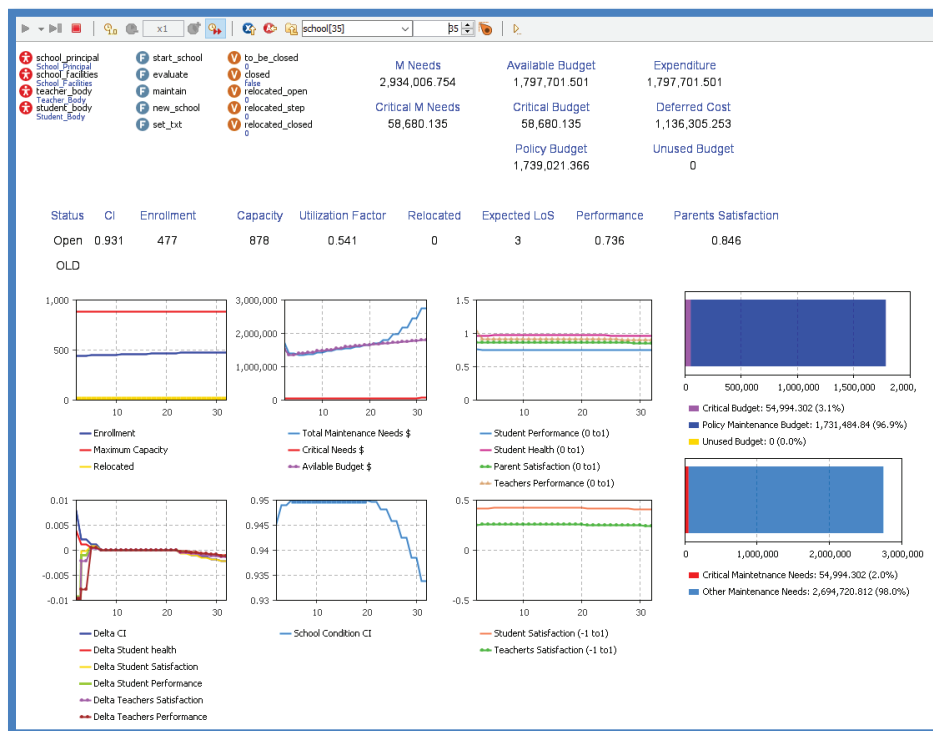

Figure 5.21 Sample Results - School 35 - Budget Factor = 5

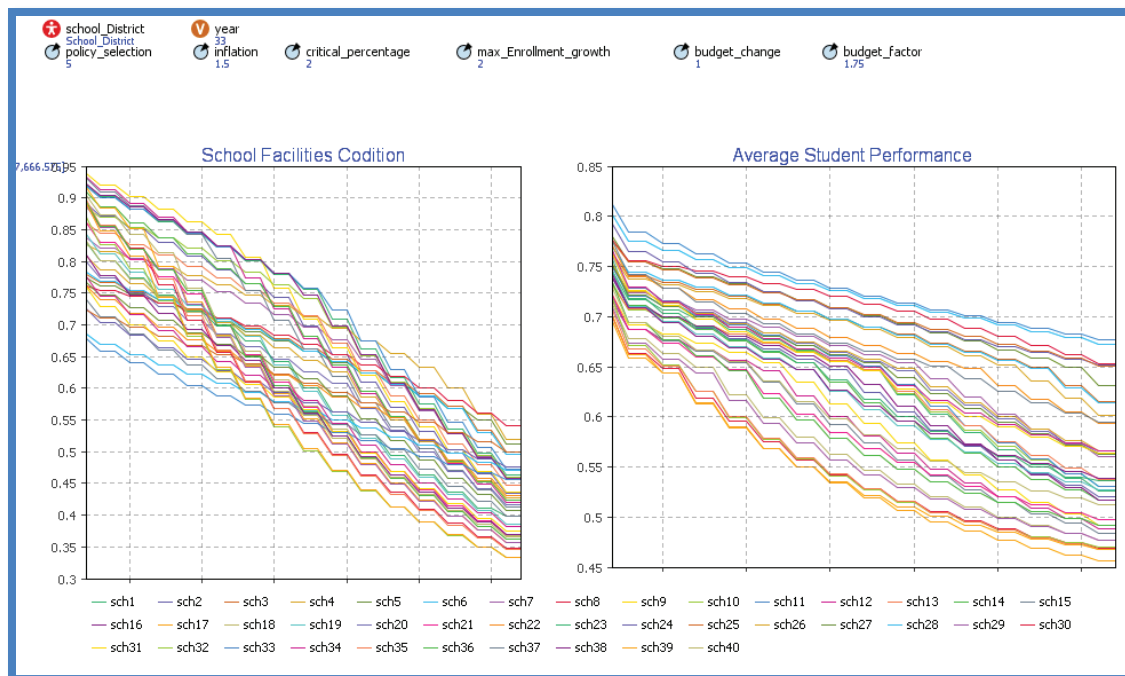

Figure 5.22 Sample Results - Budget Factor = 1.75

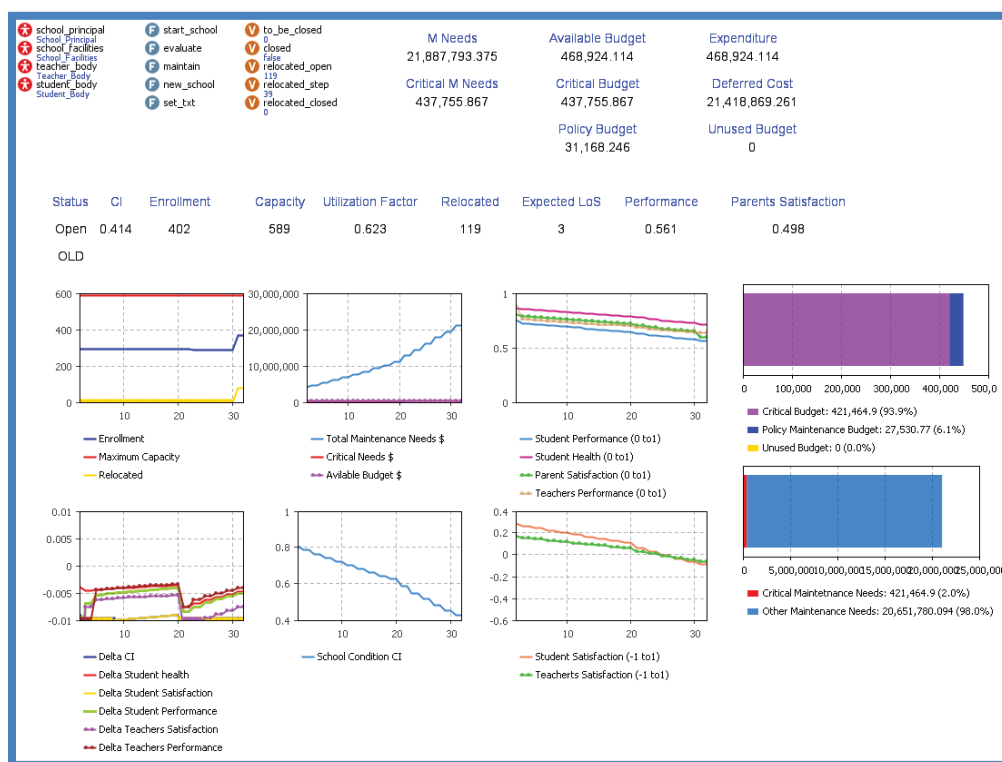

Figure 5.23 Sample Results – Single School- Budget Factor = 1.75

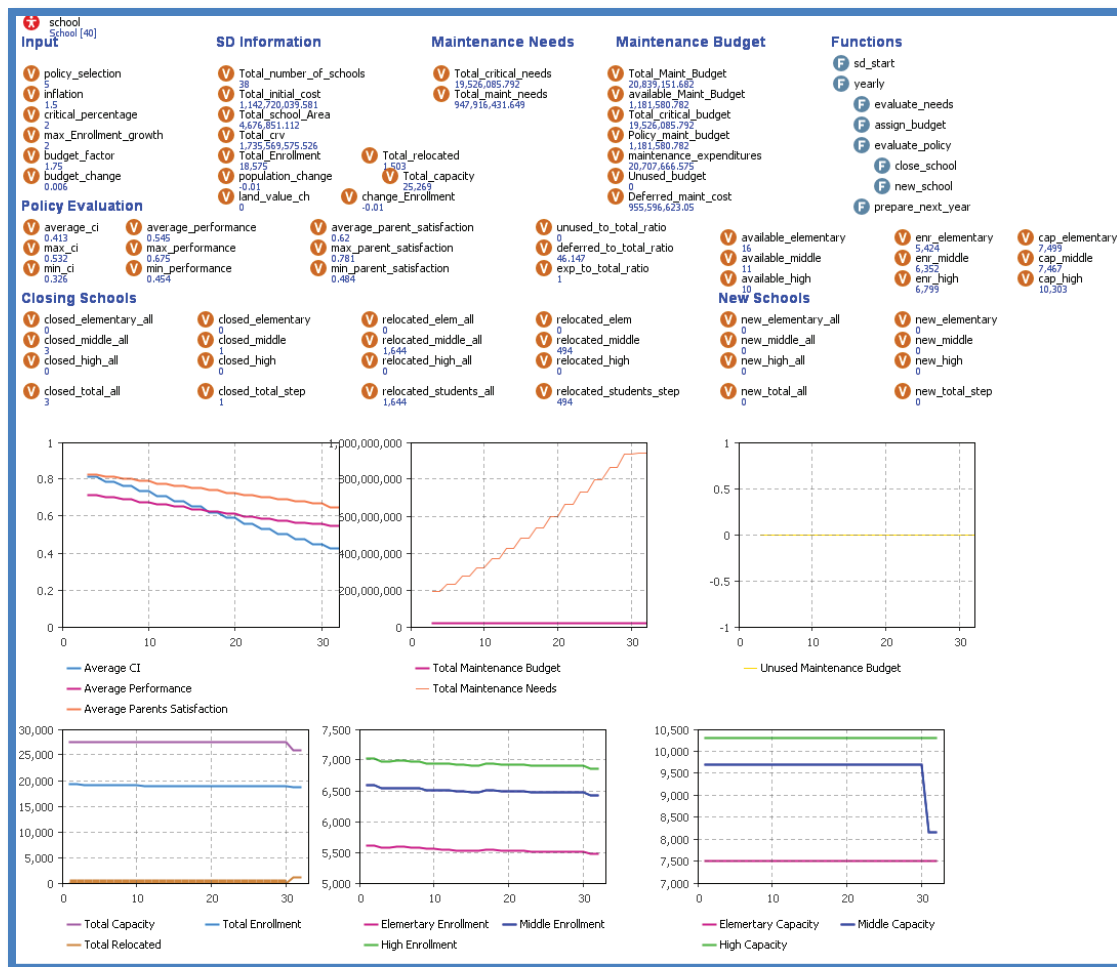

Figure 5.24 Sample Results – School District- Budget Factor = 1.75

5.3 Model Verification and Validation

Due to the dynamic nature of complex systems in addition to the stochastic nature of human behavior, conventional or empirical validation methods are not feasible approaches for agent-based modeling (ABM). Decision support ABM, such as the one proposed here aims to help decision-makers experimenting with different parameters to test their effects on the resulted outcome. For example, the proposed model can test the effects of different budget allocation policies on facility conditions, student performance, parent satisfaction, enrollment change, and local revenues collected from property tax. It can also test the effects of changing the budget factor as a percentage of the CRV to establish the targeted total maintenance budget from which to start the simulation.

ABM validation can be conducted in two steps, starting with validating the conceptual model. The proposed model concept is fully based on a literature review, industry guidelines, expert interviews, and actual practice. The intensive literature review in Chapters 2, 4, and 5 all served as a validation tool for our model.

The second step was to validate the applicability of the conceptual model and assessment of the consistency and accuracy of the simulation results, which was carried out by creating the AnyLogic program and testing the different policies and their effects on the agents' behaviors and attributes. Visualization also played an important role in assessing the reasonableness of the results as shown previously.

Verification, on the other hand, was conducted to ensure that the model was correctly built. This was achieved through inspection and testing to identify logical errors in the code. The code was tested gradually as the model was being built to assure that no code errors were made and to prevent the need for identifying errors once the entire code had been written. Again, visualization helped to spot any errors and fix them when necessary.

5.4 Summary

This chapter presented a general multi-agent model for understanding and analyzing the effects of different budget allocation policies on the condition of school facilities, student performance, enrollment size, and revenues over a period of time. The proposed model coordinates and integrates a collection of elements: principal, school facilities, teachers, students, and parents, each of which was viewed as an "agent." The proposed model is the first of its kind to explore budget allocation policies for educational assets management based on the micro-simulation of the main stakeholders' behaviors and interactions. The ABM approach was selected due to the substantial involvement of human behavior. Defining and quantifying the agents' interrelations was the greatest challenge faced in the implementation of this model.

The main advantages of using the proposed model are (1) to test the effect of different maintenance budget allocation policies on the revenues, performance, enrollment size, and property values over time; (2) to help educational facility administrators and decision-makers in adopting the most effective budget allocation approach to achieve their goals; and (3) the model is easy to customize by modifying the relations based on real life data. The proposed model has the potential to strengthen the existing decision-making processes for school maintenance budget allocations.

CHAPTER 6. SUMMARY AND CONCLUSIONS

6.1. Conclusions

The objective of this thesis was to develop an effective decision support system for the management of the maintenance resources of educational facilities with a particular focus on student outcomes and efforts to close the financing gap in education. The proposed system consists of three tools: (1) an overall condition prediction methodology that can be applied to any multi-system facility; (2) a tactical level ABM for classroom interaction to capture the two-way interactions between the major stakeholders and to test the effects of different maintenance policies; and (3) a strategic level ABM to test the effects of different maintenance budget allocation strategies on student performance.

ABM was selected to simulate both the tactical and strategic level models because the agent-based approach is capable of representing the uncertainties in human behavior and provides a more natural representation of the problem at hand. Also, ABM offers a great tool by visualizing the impact of various maintenance policies and budget allocation strategies.

First, the condition prediction methodology was introduced, which relies mainly on the facility condition index (FCI) assessment data available publicly and consists of three stages:

- The first stage of the proposed method starts by determining the overall deterioration pattern of school facilities using Markov chain stochastic modeling. The model was populated with the FCI data of Prince George's County Public Schools (PGCPS). The resulted curve was seen to slope steeply until year 23, when the deterioration pattern changed to a mild slope until the end of the model simulation.
- The next stage of the method aims to theoretically determine the average useful service-life of educational facilities without renewal by unifying the FCI data collected from the Magellan Assessment and Project Planning System (MAPPS) and the UNIFORMAT II classification used by the COMET system. The result showed that the useful service life of

educational facilities was equal to 23.6 years, which is considered a reasonable result since the model data represented four major building components (site, interiors, HVAC, and electrical) that consume about 70% of the total maintenance funding and have a useful service-life between 21.5 and 25 years.

- The last stage of the method defines the lower and upper limits of the deterioration rates by presenting the case where the building is well maintained and the case where the building receives no maintenance. It was found that educational facility deterioration can be assumed to be linear through the first 23 years with a slope equal to 1.6%, 2.4%, and 3.6% for the following cases, respectively: a) recommended maintenance performed, b) Markov chain model results, and c) no maintenance done.

Second, a tactical level ABM was created to capture the mutual day-by-day relationship between the indoor environmental quality (IEQ) and the classroom occupants. The model aims to provide decision-makers with insight into the dynamics of classroom interactions and enables them to test the effects of different maintenance policies on the system's major stakeholders. The model was developed using a system of systems (SoS) proto-method, which consists of the definition phase, the abstraction phase, and the implementation phase. Several smaller models were created to better represent the stakeholders' behavior, such as the following:

- Students' social network formation and effects model: a modified version of the conceptual model developed by Ballato (2012) and Schuhmacher et al. (2014). The model utilizes the similarity and peer effect theories to evaluate behavioral changes in the students.
- Fuzzy logic IEQ satisfaction model: to convert thermal sensation, IAQ acceptability, and tolerance, which was affected by the noise level, to a single satisfaction value that is independent of its previous value.

- Human agent's perception evaluation model: to represent the unique nature of human behavior and take into consideration the effects of both previous and current experiences on human perception.
- HVAC system deterioration model: to represent the HVAC system condition changes due to aging, unforeseen failures, and vandalism and misuse. The model offers a unique and simple method to evaluate aging deterioration for HVAC systems based on the knowledge of the recommended preventive maintenance data.
- HVAC system failure prioritization model: to prioritize the needed repairs according to activeness, status, deferring consequences, scope, repair and delay cost, and student performance.

The applicability of the model was tested with a case study using AnyLogic simulation software. The developed model can provide decision-makers with a holistic understanding of the current situation and help them optimize the use of available resources.

Third, a strategic level ABM was developed to evaluate the effects of different budget allocation strategies on the main stakeholders and to gain a better understanding of the macro system dynamics. The model aimed to enhance the utilization of available limited resources. Like the tactical model, the strategic ABM was developed using the proto-method. In addition to modeling the two-way interaction between the stakeholders, the model provides a method to test the effect of school closings on their facilities, students, parents, and enrollment size.

The results of the strategic level model emphasized the important role of the community in better understanding of the importance of their involvement in helping decision-makers plan for high quality facilities. The results also highlight the importance of finding new and innovative funding sources like public private partnerships.

6.2. Research Contribution

The main contributions of this research can be summarized as follows:

- The development of a three-stage methodology for educational facilities condition prediction through the utilization of already available FCI data. The developed methodology can be used for any multi-system asset for deterioration modeling purposes.
- The development of a tactical level decision support system by the means of ABM that can simulate the dynamics of classroom interactions to gain a better understanding of the problems and to test the effects of different HVAC system maintenance policies. The model is the first of its kind to explore the effects of different maintenance approaches in the educational infrastructure context through micro-modeling of the different stakeholders' behaviors and interactions.
- The development of a strategic level ABM for educational facilities maintenance budget allocation policy selection. To the best knowledge of the author, there are no such models in the current body of literature for the analysis of budget allocation policies in the context of educational assets management by the means of ABM and with focus on student outcomes.

6.3. Future Research

Several future research directions were recognized during the research and include the following: (1) a state level agent-based decision support system to test the effects of different financing alternatives and to test the effects of partnering with the private sector to close the current financial gap and (2) a hybrid state level ABM to examine and evaluate the effects of community involvement on the quality of life and equality with a special focus on educational infrastructure. The proposed model could integrate a geographical information system (GIS) to add a new dimension for understanding and evaluating the importance of community involvement.

REFERENCES

- Abate, D., Towers, M., Dotz, R., & Romani, L. (2009). The Whitestone Facility Maintenance and Repair Cost Reference 2009–2010. Whitestone Research, California.
- Abaza, K. A. (2016). Simplified staged-homogenous Markov model for flexible pavement performance prediction. *Road Materials and Pavement Design*, 17(2), 365-381.
- Abbas, A. (2015, August). Personal interview.
- Abdelrahim, A., & George, K. (2000). Artificial neural network for enhancing selection of pavement maintenance strategy. *Transportation Research Record: Journal of the Transportation Research Board*, (1699), 16-22.
- Abdou, W. (2015, August). Personal interview.
- Abdulrazzak, M. (2015, July). Personal interview.
- Aboura, K., Samali, B., Crews, K., & Li, J. (2009). Stochastic Processes for modeling bridge deterioration. *Futures in mechanics of structures and materials*, 533-538.
- Abraham, D. M., & Wirahadikusumah, R. (1999). Development of prediction models for sewer deterioration. *Durability of Building Materials and Components*.
- Abramson, P. (2012). 17th Annual School Construction Report. *School Planning and Management Magazine*.
- Abramson, P. (2015). 20th Annual School Construction Report. *School Planning and Management Magazine*.
- Ahluwalia, S. S. (2008). A framework for efficient condition assessment of the building infrastructure (Doctoral dissertation, University of Waterloo).
- Ahrentzen, S. & Evans, G. W. (1984). Distraction, privacy, and classroom design. *Environment and Behavior*, 16(4), 437-454.
- Akbar, A. (2015, September). Personal interview.
- Albader, H. & Kandil, A. (2013). An Agent-based Framework of a Maintenance Budget Allocation System for Educational Facilities. *GEN*, 62, 1.
- Alberta Infrastructure (2000). School facility evaluation project: Final results.
- Aldosary, E. (2015, August). Personal interview.

- Al-Enezi, M. M. (2002). A study of the relationship between school building conditions and academic achievement of twelfth grade students in Kuwait public high schools. Unpublished doctoral dissertation, Virginia Polytechnic Institute and State University, Blacksburg, VA.
- Alexander, D. & Lewis, L. (2014). Condition of America's Public School Facilities: 2012-13. First Look. NCES 2014-022. National Center for Education Statistics.
- Alfailakawi, E. (2015, September). Personal interview.
- Alfano, F., Bellia, L., Dijken, F., Ianniello, E., Lopardo, G., Minichiello, F, Silva, M. (2010). Ambiente Interior e Eficiência Energética nas Escolas. 1ª Parte-Princípios), Manual REHVA nº13, Ingenium Edições, Lisboa.
- Alhaib,S. (2015, September). Personal interview.
- Alhasan, A. (2015, August). Personal interview.
- Alhashmi, H. (2016, April 5). Personal interview.
- Alkhouri, A. (2016, April 5). Personal interview.
- Almanfi, A. (2015, September). Personal interview.
- Almeida, R. M., Freitas, V. P. & Delgado, J. M. (2015). School Buildings Rehabilitation: Indoor Environmental Quality and Enclosure Optimization. New York: Springer International Publishing.
- Alqatari, S. (2015, September). Personal interview.
- Alsahaf, F. (2015, September). Personal interview.
- Alsayed, M. (2016, April 5). Personal interview.
- Ana, E. V., & Bauwens, W. (2010). Modeling the structural deterioration of urban drainage pipes: the state-of-the-art in statistical methods. *Urban Water Journal*, 7(1), 47-59.
- APPA, et. al. (2003). Asset Lifecycle Model for Total Cost of Ownership Management: Framework, Glossary, and Definitions.
- ASCE. (2013).2013 Report Card for America's Infrastructure Findings. www.infrastructurereportcard.org/a/documents/Schools.pdf.
- ASCE. (2017). 2017 Report Card for America's Infrastructure. Retrieved July 2017. www.infrastructurereportcard.org
- ASHRAE (2011). HVAC Applications Handbook. IP Edition.

- ASTM international (2007) Standard Classification for Building Elements and Related Sitework (UNIFORMAT II), <http://proyectablog.files.wordpress.com/2009/05/a-1-1-e1557-05-uniformat-ii.pdf>.
- Audin, L. (2009). Selling the CEO on HVAC Upgrades: <https://www.facilitiesnet.com>.
- Ayres, P. D. (1999). Exploring the relationship between high school facilities and achievement of high school students in Georgia. Unpublished doctoral dissertation, University of Georgia, Athens, GA.
- Baik, H. S., Jeong, H. S., & Abraham, D. M. (2006). Estimating transition probabilities in Markov chain-based deterioration models for management of wastewater systems. *Journal of water resources planning and management*, 132(1), 15-24.
- Bailey, J. A. (2009). A synthesis of studies pertaining to building conditions, student achievement, student behavior, and student attitude (Doctoral dissertation, Virginia Polytechnic Institute and State University).
- Bakó-Biró, Z., Kochhar, N., Clements-Croome, D.J., Awbi, H.B., & Williams, M. (2008). Ventilation rates in schools and pupils' performance using computerised assessment tests. *Indoor Air 2008, Copenhagen, 11th International Conference on Indoor Air Quality and Climate*.
- Bakó-Biró, Z., Clements-Croome, D. J., Kochhar, N., Awbi, H. B., & Williams, M. J. (2012). Ventilation rates in schools and pupils' performance. *Building and Environment*, 48, 215-223.
- Bakó-Biró, Z., Kochhar, N., Clements-Croome, D.J., Awbi, H.B., & Williams, M. (2007) Ventilation rates in schools and learning performance. In: *Proceedings of CLIMA 2007 WellBeing Indoors, The 9th REHVA World Congress, Helsinki, Finland, 1434-1440*.
- Bakó-Biró, Z., Wargocki, P., Weschler, C.J., & Fanger, P.O. (2004). Effects of pollution from personal computers on perceived air quality, SBS symptoms, and productivity in offices. *Indoor Air*, 14, 178–187.
- Ballato, L. (2012). If I like you, I wanna be like you! The use of dynamic systems modeling in the understanding of friendship interactions and risk behaviors during adolescence (Doctoral dissertation, University of Groningen).

- Bandara, N., & Gunaratne, M. (2001). Current and future pavement maintenance prioritization based on rapid visual condition evaluation. *Journal of Transportation Engineering*, 127(2), 116-123.
- Battles, A. B. (2006). The use of full-spectrum lighting to enhance academic achievement, attendance, sense of wellbeing, and on task behavior in special education. Unpublished doctoral dissertation, Tennessee State University, Nashville, TN.
- Bell, P. A. (1981). Physiological, comfort, performance, and social effects of heat stress. *Journal of Social Issues*, 37(1), 71-94.
- Berner, M.M. (1993). Building condition, parental involvement, and student achievement in the District of Columbia Public School System. *Urban Education*, 28 (1), 6-29.
- Bocchini, P., Saydam, D., & Frangopol, D. M. (2013). Efficient, accurate, and simple Markov chain model for the life-cycle analysis of bridge groups. *Structural Safety*, 40, 51-64.
- Bonabeau, E. (2002). Agent-based modeling: Methods and techniques for simulating human systems. *Proceedings of the National Academy of Sciences of the United States of America*, 99(Suppl 3), 7280-7287.
- Borshchev, A., & Filippov, A. (2004). From system dynamics and discrete event to practical agent based modeling: reasons, techniques, tools. In *Proceedings of the 22nd international conference of the system dynamics society* (No. 22).
- Bowers, J. H. & Burkett, C. W. (1988). Physical environment influences related to student achievement, health, attendance and behavior. *QEFJ Journal*.
- Bowers, J. H. & Burkett, G. W. (1987). Relationship of student achievement and characteristics in two selected school facility environmental settings. Edmonton, Alberta, Canada: 64th Annual International conference of the Council of Educational Facility Planners. (ERIC Reproduction Service No. ED 286278).
- Brannon, W. (2000). A study of the relationship between school leadership and the condition of school buildings. Unpublished doctoral dissertation, Virginia.
- Briselden, D.J. and D.A. Cain. (2001) The Facilities Condition Index: A Useful Tool for Capital Asset Planning. *Facilities Manager*, volume 17, number 4, July/August.
- British Standards Institution (BSI). (1993). Glossary of Terms Used in Terotechnology. BS 3811:1993.

- Bullock, C. C. (2007). The relationship between school building conditions and student achievement at the middle school level in the Commonwealth of Virginia. Unpublished doctoral dissertation, Virginia Polytechnic Institute and State University, Blacksburg, VA.
- Burgess, J., & Fordyce, W. K. (1989). Effects of preschool environments on nonverbal social behavior: Toddlers' interpersonal distances to teachers and classmates change with environmental density, classroom design, and parent-child interactions. *Journal of Child Psychology and Psychiatry*, 30(2), 261-276.
- Bush, M., Ryan, M., & Rose, S. (2011). Number of instructional days/hours in the school year. Education Commission of the United States. <http://www.ecs.org/clearinghouse/95/05/9505.pdf>.
- Butt, A., Shahin, Y., Feighan, J., and Carpenter, H.(1987) Pavement performance prediction model using the Markov process. *Transp. Res. Rec.*, 1123, 12-19.
- Cable, J. H., Davis, J. S., Hoc, F. F. C. A., & Council, F. F. (2005). Key Performance Indicators for Federal Facilities Portfolios: Federal Facilities Council Technical Report Number 147 (Vol. 147). National Academies Press.
- Cain, D. & Kinnaman, M.(2004), The Needs Index: The New and Improved FCI, Facilities Manager, APPA, March/April , PP 44-49. <http://www.appa.org>.
- California Department of Education (CDE) (2013). The Williams Case -- An Explanation. <http://www.cde.ca.gov/eo/ce/wc/wmslawsuit.asp>.
- Canada: 64th Annual International conference of the Council of Educational Facility Planners. (ERIC Reproduction Service No. ED 286278).
- Cash, C. (1993). Building Condition and Student Achievement and Behavior. Unpublished Doctoral Dissertation, Virginia Polytechnic Institute and State University, Blacksburg, Va.
- Cervantes, R. P. (1999). The condition of school facilities as related to student achievement and behavior. Unpublished doctoral dissertation, University of Alabama, Tuscaloosa, AL. *Dissertation Abstracts*, 54, 03A.
- Cesare, M. A., Santamarina, C., Turkstra, C., & Vanmarcke, E. H. (1992). Modeling bridge deterioration with Markov chains. *Journal of Transportation Engineering*, 118(6), 820-833.
- Chan, T. C. (1979). The impact of school building age on pupil achievement. Greenville, SC: Greenville County School District. (ERIC Document Reproduction Service No. ED 191 138).

- Chan, T. C. (1980). Physical Environment and Middle Grade Achievement. (ERIC Document Reproduction Service No. ED 198 645).
- Chan, T. C. (1982). Pupil Attitudes Toward New and Old Buildings. *Educational Facility Planner*, 21 (2) 18-19.
- Chaney, B. & Lewis, L. (2007). Public School Principals Report on Their School Facilities: Fall 2005 (NCES 2007-007). U.S. Department of Education. Washington, DC: National Center for Education Statistics.
- Charette, R. P. & Marshall, H. E. (1999). UNIFORMAT II elemental classification for building specifications, cost estimating, and cost analysis. U.S. Department of Commerce, Technology Administration, National Institute of Standards and Technology.
- Charles, K. E. (2003). Fanger's thermal comfort and draught models. Institute for Research in Construction. IRC Research Report RR-162.
- Charles, M. M., & Michael, J. N. (2006). Tutorial on agent-based modeling and simulation part 2: how to model with agents. In *Proceedings of the 38th Winter Simulation Conference*, Monterey, CA (pp. 73-83).
- Cheng, Y. C. (1994). Classroom environment and student affective performance: An effective profile. *Experimental Education*, 62(3), 221-239.
- Christie, D. J. & Glickman, C. D. (1980). The effects of classroom noise on children: Evidence for sex differences. *Psychology in the Schools*, 17, 405-408.
- Chu, J., Wang, C., Chen, J., & Wang, H. (2009). Agent-based residential water use behavior simulation and policy implications: A case-study in Beijing City. *Water resources management*, 23(15), 3267-3295.
- Clayton, J. (2012). Condition Assessment in Facility Asset Management .In: Teicholz, E., & IFMA Foundation. *Technology for facility managers: The impact of cutting-edge technology on facility management*. Hoboken, New Jersey: John Wiley & Sons, Inc., PP. 137-169
- Clements-Croome, D.J., Awbi, H.B., Bakó-Biró, Z., Kochhar, N., & Williams, M. (2008). Ventilation rates in schools. *Building and Environment*, 43(3), 362-367.
- Cohen, S. & Trostle, S. L. (1990). Young children's preferences for school-related physical environmental setting characteristics. *Environment and behavior*, 22(6), 753-766.
- Cohen, S., Evans, G., Krantz, D. S., & Stokols, D. (1980). Psychological, motivational, and cognitive effects of aircraft noise on children. *American Psychologist*, 35, 231-243.

- Colorado Department of Education. (2010). Statewide Financial Assistance Priority Assessment FY 2009-2010.
- Collins, L. (1975). An Introduction to Markov Chain Analysis, Geo Abstracts.
- Council of the Great City Schools (2014). Reversing the Cycle of Deterioration in the Nation's Public School Buildings, October 2014.
- Crampton, F. E., & Thompson, D. C. (2008). Building Minds, Minding Buildings. School Infrastructure Funding Need: A State-by-State Assessment and an Analysis of Recent Court Cases. American Federation of Teachers.
- Crook, J. F. (2006). A study of school building conditions and student achievement in the high schools of Virginia. Unpublished doctoral dissertation, Virginia Polytechnic Institute and State University, Blacksburg, VA.
- Cui, W., Cao, G., Park, J. H., Ouyang, Q., & Zhu, Y. (2013). Influence of indoor air temperature on human thermal comfort, motivation and performance. *Building and Environment*, 68, 114-122.
- Cunningham, Magellan, DeJONG, & Hallberg. (2009). Facilities Conditions & Educational Adequacy Assessment Summary for Saint Paul Public Schools.
- Danylo, N. H., & Lemer, A. (1998). Asset Management for the Public Works Manager: Challenges and Strategies—Findings of the APWA Task Force on Asset Management. [www. apwa. net/documents/resourcecenter/ampaper. rtf](http://www.apwa.net/documents/resourcecenter/ampaper.rtf), 1998-08-31.
- De Dear, R. J., Brager, G. S., Reardon, J., & Nicol, F. (1998). Developing an adaptive model of thermal comfort and preference/Discussion. *ASHRAE Transactions*, 104, 145.
- DeJong-Richter LLC, Magellan Consulting, Cunningham Group, & BLGY Architecture (2011). Austin Independent School District District-Wide Facility Master Plan.
- DeLaurentis, D. (2005). Understanding transportation as system-of-systems design problem. 43rd AIAA Aerospace Sciences Meeting and Exhibit, 10-13 January 2005, Reno, NV.
- DeLaurentis, D. 2005. Understanding transportation as System-of-Systems design problem. 43rd AIAA Aerospace Sciences Meeting and Exhibit, January 10-13, 2005, Reno, Nevada.
- DeStefano, P. D., & Grivas, D. A. (1998). Method for estimating transition probability in bridge deterioration models. *Journal of Infrastructure Systems*, 4(2), 56-62.
- Doe, John. (2001). California State University life cycle cost worksheet: https://www.calstate.edu/cpdc/ae/Forms/Life_Cycle_Cost_Worksheet.xls.

- Dorgan, C. B. (2001). The effect of lighting and cooling system improvements on test performance. Unpublished doctoral dissertation, University of Wisconsin, Madison, WI. Dissertation abstracts, AAI3033304.
- Dorris, D. (2011). A validation of the Effective Learning Environments Assessments. Tarleton State University.
- Durán-Narucki, V. (2008). School building condition, school attendance, and academic achievement in New York City public schools: A mediation model, *Journal of Environmental Psychology*, Volume 28, Issue 3, Pages 278-286, ISSN 0272-4944.
- Earthman, G. I. (2004). Prioritization of 31 criteria for school building adequacy: American Civil Liberties Union Foundation of Maryland. <http://www.schoolfunding.info>.
- Earthman, Glen I.; Cash, Carol S.; Van Berkum, Denny. (1995). A Statewide Study of Student Achievement and Behavior and School Building Condition. (ERIC Document Reproduction Service No. ED 387 878).
- Edirisinghe, R., Setunge, S., & Zhang, G. (2015). Markov model—based building deterioration prediction and ISO factor analysis for building management. *Journal of Management in Engineering*, 31(6), 04015009.
- Edmonds, B. & Chattoe, E. (2005). When simple measures fail: Characterising social networks using simulation. In *Social Network Analysis: Advances and Empirical Applications Forum*. Oxford, UK.
- Edwards, Maureen M. (1991). Building Conditions, Parental Involvement and Student Achievement in D. C. Public School System. (ERIC Document Reproduction Service No. ED 338 743).
- Edwards, N. C. (2006). School facilities and student achievement: student perspectives on the connections between the urban learning environment and student motivation and achievement. Unpublished doctoral dissertation, The Ohio State University, Columbus, OH.
- Elhakeem, A. A. (2006). An asset management framework for educational buildings with life-cycle cost analysis. ProQuest. Chicago.
- Ellerson, N. & Domenech, D. (2012). Cut Deep: How the Sequester Will Impact Our Nation's Schools. American Association of School Administrators. <http://www.aasa.org>.

- Epstein, J. M., and Axtell, R.. (1996). *Growing Artificial Societies: Social Science from the Bottom Up*. Cambridge, MA: MIT Press.
- Fang, L., Clausen, G., & Fanger, P. O. (1998). Impact of temperature and humidity on the perception of indoor air quality. *Indoor air*, 8(2), 80-90.
- Fang, L., Wargocki, P., Witterseh, T., Clausen, G., & Fanger, P. O. (1999). Field study on the impact of temperature, humidity, and ventilation on perceived air quality. *Proceedings of Indoor Air*, 99(2), 107-112.
- Fang, L., Wyon, D. P., Clausen, G. & Fanger, P. O. (2004). Impact of indoor air temperature and humidity in an office on perceived air quality, SBS symptoms, and performance. *Indoor Air*, 14: 74–81. doi: 10.1111/j.1600-0668.2004. 00276.x.
- Fang, L., Wyon, D. P., Clausen, G., & Fanger, P. O. (2002). Sick building syndrome symptoms and performance in a field laboratory study at different levels of temperature and humidity. *Proceedings of Indoor Air 2002*.
- Fanger, P. O. (1970). *Thermal comfort. Analysis and applications in environmental engineering*.
- Federspiel, C.C., Liu, G., Lahiff, M., Faulkner, D.L., Dibartolomeo, D.L., Fisk, W.J., Rice, P.N., & Sullivan, D.P. (2002). Worker performance and ventilation: Analyses of individual data for call center workers. In *Proceedings of Indoor Air 2002*, 1,96-801.
- Filardo, M. (2016). *State of Our Schools: America’s K–12 Facilities 2016*, Washington, DC: 21st Century School Fund.
- Flintsch, G. W., & Chen, C. (2004). Soft computing applications in infrastructure management. *Journal of Infrastructure Systems*, 10(4), 157-166.
- Flygt, E. (2009). Investigating Architectural Quality Theories for School Evaluation A Critical Review of Evaluation Instruments in Sweden. *Educational Management Administration & Leadership*, 37(5), 645-666.
- Fuligni, A. J. (1997). The academic achievement of adolescents from immigrant families: The role of family background, attitudes, and behavior. *Child Development*, 68(2), 351-363.
- Fuselier, C. (2008). A study of the relationship between selected building facility components and achievement scores in Pennsylvania middle schools. Unpublished doctoral dissertation, Duquesne University, Pittsburg, PA.
- Gallagher, M. & Gold, A. (2017). *Adding and Subtracting Schools: Examining School Change for Students and Communities*.

- Gao, H., & Zhang, X. (2013). A Markov-Based Road Maintenance Optimization Model Considering User Costs. *Computer-Aided Civil and Infrastructure Engineering*, 28(6), 451-464.
- Gao, J., Wargocki, P., & Wang, Y. (2014). Ventilation system type, classroom environmental quality, and pupils' perceptions and symptoms. *Building and Environment*, 75, 46-57.
- Garrett, D. M. (1980). The impact of school building age on the academic achievement of selected eleventh grade pupils in the state of Georgia (Doctoral Dissertation, The University of Georgia, 1980). *Dissertation Abstracts International*, 41, 4231A.
- Geier, B. A. (2007). Michigan elementary school facility quality and its impact of student achievement. Unpublished doctoral dissertation, Western Michigan University, Kalamazoo, MI. *Dissertation abstracts*, AAI3293168.
- General Accounting Office. (1995). *School Facilities: Condition of America's Schools*. GAO/HEHS-95-61. Washington, DC: GAO. <http://www.gao.gov/products/HEHS-95-61>.
- Gentry, K. J. (2000). The Relationship between school size and academic achievement in Georgia's public high schools. Unpublished doctoral dissertation, University of Georgia, Athens, GA.
- Gilbert, N. (2008). *Agent-based Models* (No. 153). Sage.
- Ginn J. (2013). Why Johnny Can't Ride the Bus: Schools Struggle with Cuts as State Revenues Continue to Lag. The Council of State Governments. http://www.csg.org/pubs/capitolideas/sept_oct_2012/educationbudgetcuts.aspx.
- Gordon, M.F., de la Torre, M., Cowhy, J.R., Moore, P.T., Sartain, L.S., & Knight, D. (2018). School closings in Chicago: Staff and student experiences and academic outcomes. University of Chicago Consortium on School Research.
- Goto, T. & Ito, K. (2009) The effects of indoor temperature and outdoor air supply rate on learning performance of late-teen students.
- Grangaard, E. M. (1995). Color and light effect on learning. (Report No. PS 023272). Washington, DC: Association for Childhood Education International Study Conference and Exhibition.
- Gratch, J. & Marsella, S. (2004). A domain-independent framework for modeling emotion. *Cognitive Systems Research*, 5(4), 269-306.

- Guy, L. G. (2001). Student achievement and school condition: Examining the relationship in West Virginia's high schools. Unpublished doctoral dissertation, West Virginia University, Morgantown, PA. Dissertation abstracts, AAI3104938.
- Haines, M. M., Stansfeld, S.A., Brentnall, S., et al. (2001). The West London School Study: the effects of chronic aircraft noise exposure on child health. *Psychology Med.* 3, 1385-1396.
- Harting, R.D. & Delon, F.G. (1990). Can classroom lighting affect absence rates? *ERS Spectrum*, 8(2), 3-10.
- Hathaway, W. E. (1995). Effects of school lighting on physical development and school performance. *Journal of Educational Research*, §8(4), 228-242.
- Haverinen-Shaughnessy, U., Moschandreas, D. J., & Shaughnessy, R. J. (2011). Association between substandard classroom ventilation rates and students' academic achievement. *Indoor Air*, 21(2), 121-131.
- Haverin-Shaughnessy, U. & Turunen, M. (2012). Sixth grade pupils' health and performance and indoor environmental quality in Finnish school buildings. *British Journal of Education Research*, 2(1), 42-58.
- Hawkins, H. & Lilley, H. (1998), Guide for school facility appraisal 1998 edition: instrument for high school appraisal, The Council of Educational Facility Planners International CEFPI
- Hawkins, H. L., Lilley, H. E., & Council of Educational Facility Planners, International. (1992). Guide for school facility appraisal. Columbus, Ohio: Council of Educational Facility Planners, International.
- Heath, B., Hill, R., & Ciarallo, F. (2009). A Survey of Agent-Based Modeling Practices. *Journal of Artificial Societies & Social Simulation*, 12(4).
- Hedfi, A., & Stephanos, P. (2001). Pavement performance modeling: an applied approach at the state of Maryland. In *Fifth International Conference on Managing Pavements*.
- Helal, M. (2015, September). Personal interview.
- Heschong Mahone Group. (1999). Daylighting in schools: An investigation into the relationship between daylighting and human performance. Fair Oaks: California Board for Energy Efficiency Third Party Program. Submitted to Pacific Gas and Energy.
- Heschong Mahone Group. (2003). Windows and classrooms: A study of student performance and the environment. California Energy Commission; Technical Report. Submitted to the California Energy Commission.

- Hickman, P. (2002). New high schools in Ohio: Relationships between school facilities and staff behavior and attitudes. Unpublished doctoral Dissertation, Ashland University, Ashland, OH.
- Hines, Eric W. (1996). Building Condition and Student Achievement and Behavior. Unpublished doctoral dissertation, Virginia Polytechnic Institute and State University, Blacksburg, Va.
- Hoffman, L. (2010). Numbers and Types of Public Elementary and Secondary Schools From the Common Core of Data: School Year 2007–08 (NCES 2010-305). National Center for Education Statistics, Institute of Education Sciences, U.S. Department of Education. Washington, DC. 04/18/2014 from <http://files.eric.ed.gov/fulltext/ED506743.pdf>.
- Holmberg, I., & Wyon, D. P. (1967). Skolprestationernas beroende av temperaturen i klassrummet. Pedagogisk-psykologiska problem , Nr. 55 , 44 p. (English language version, 1969, The dependence of performance in school on classroom temperature. Educational and Psychological.
- Huang, Y., & Moore, R. (1997). Roughness level probability prediction using artificial neural networks. Transportation Research Record: Journal of the Transportation Research Board, (1592), 89-97.
- Hyatt, C. L. (1982). The effect of jet aircraft noise on student achievement and attitude toward classroom environment. Unpublished doctoral dissertation, Seattle University, Washington.
- Ingraham, L. (1983). Electromagnetic Radiation and Student Off-Task Behaviors. Edmonton: Alberta Department of Education.
- International Facility Management Association (IFMA) (2002), A Framework for Facilities Lifecycle Cost Management Asset Lifecycle Model for Total Cost of Ownership Management Framework, International Facility Management Association, Houston, Texas, USA. <http://www.ifma.org>.
- Issa, M. H., Rankin, J. H., Attalla, M., & Christian, A. J. (2011). Absenteeism, performance, and occupant satisfaction with the indoor environment of green Toronto schools. Indoor and Built Environment, 20(5), 511-523.
- Jaakkola, J. J. K., Heinonen, O. P., & Seppänen, O. (1989). Sick building syndrome, sensation of dryness and thermal comfort in relation to room temperature in an office building: Need for individual control of temperature. Environment International, 15(1), 163-168.

- JACOBS, Dejong-Richter, & Grimm + Parker.(2012). Baltimore City Public Schools State of School Facilities.
- Jacobs, Magellan Consulting, DeJONG, & MOA Architecture. (2010) Jefferson Public Schools Facilities Conditions Assessment Summary of Findings. http://www.jeffcopublicschools.org/business/facil_plan_design_const/documents/2011.01_Jeffco%20Summary%20of%20Findings.pdf.
- Jeffco planning & property (2012).2012-2013 Facility condition assessment summary of findings. Jeffco public schools.
- Jiang, Y., Saito, M., and Sinha, K. C. (1988) Bridge performance prediction model using the Markov chain. *Transp. Res. Rec.*, 1180, 25– 32.
- Jin, Y., & Mukherjee, A. (2014). Markov chain applications in modelling facility condition deterioration. *International Journal of Critical Infrastructures*,10(2), 93-112.
- Johnson, N. Oliff, P. and Williams,E. (2011) . An Update on State Budget Cuts: At Least 46 States Have Imposed Cuts That Hurt Vulnerable Residents and the Economy. Center on Budget and Policy Priorities. February 9, 2011. <http://www.cbpp.org/files/3-13-08sfp.pdf>.
- Johnson, R. L. (2005). High and dry. *American School & University*, 78(4), 34-36.
- Jones, M. (2013). Condition of Florida educational facilities and balancing budgets. Alabama State University.
- Joshi, S. M. (2008). The sick building syndrome. *Indian Journal of Occupational and Environmental Medicine*, 12(2), 61–64. <http://doi.org/10.4103/0019-5278.43262>.
- Jue, G. M. (1990). Toward an understanding of stress in the classroom: The role of individual differences and physical design factors. Irvine, CA: Unpublished doctoral dissertation, University of California.
- Kaczmarczyk, J., Melikov, A. & Fanger, P.O. (2004) Human response to personalized ventilation and mixing ventilation. *Indoor Air* 14 (Suppl.).
- Kaiser, H. (2009). Facilities Condition Assessment , APPA: Leadership in Educational Facilities, Alexandria, Virginia.
- Kalz, D. & Pfafferott, J. (2014). Thermal Comfort and Energy-Efficient Cooling of Nonresidential Buildings. Springer Science & Business Media.

- Karst, R. R. (1983). Comparing environmental quality with user attitude: A MEEB model application. Paper presented at the meeting of the Council of Education Facility Planners, International, Orlando, FL.
- Kaufman, S. S. (1984). Stresses and coping styles of elementary school children (Doctoral dissertation, Arizona State University).
- Khan, F. I. & Haddara, M. M. (2003). Risk-based maintenance (RBM): A quantitative approach for maintenance/inspection scheduling and planning. *Journal of Loss Prevention in the Process Industries*, 16(6), 561-573.
- Kilpatrick, Anita A. (2003). Facility condition as an influence on school climate: A study of two separate secondary school settings. Unpublished doctoral dissertation, University of Alabama, Tuscaloosa, AL.
- Kirk, S.J. & Dell'Isola, A.J. (1995). *Life Cycle Costing for Design Professionals*. New York: McGraw-Hill, Inc.
- Knight, C. B. (1990). Effects of learning style accommodation on achievement of second graders. Paper presented at the meeting of the Mid-south Educational Research Association, New Orleans, LA.
- Kort B.& Reilly R. (2002) Theories for deep change in affect-sensitive cognitive machines: a constructivist model. *Educational technology & society* 5 (4) 2002. ISSN 1436-4522
- Krimsky, J.S. (1982). A comparative study of the effects of matching and mismatching fourth grade students with their learning style preferences for the environmental element of light and their subsequent reading speed and accuracy scores. Doctoral Dissertation, St. John's University.
- La Torre, F., Domenichini, L., & Darter, M. I. (1998). Roughness prediction model based on the artificial neural network approach. In *Proceedings of the fourth International Conference on Managing Pavements, Durban, Afrique du sud* (Vol. 2, p. 599).
- Lackney, J. A. (1999). Assessing school facilities for learning/assessing the impact of the physical environment on the educational process. Mississippi State, Educational Design Institute. (ERIC Document Reproduction Service No. ED441330).
- Lackney, J.A. & Chang, C. (2003). A Longitudinal Investigation of Building Condition, Educational Adequacy and Educational Outcomes in the Milwaukee Public Schools. Retrieved November 18, 2003. <http://schoolstudio.engr.wisc.edu/mpsinvestigation.html> .

- Lair, S. (2003). A study of the effect school facility conditions have on student achievement. Unpublished doctoral dissertation, University of Texas at Austin, Austin, TX. Dissertation abstracts.
- Lan, L., Wargocki, P., & Lian, Z. (2012). Optimal thermal environment improves performance of office work. *REHVA Journal* (January 2012), 12-17.
- Lan, L., Wargocki, P., & Lian, Z. (2014). Thermal effects on human performance in office environment measured by integrating task speed and accuracy. *Applied Ergonomics*, 45(3), 490-495. 10.1016/j.apergo.2013.06.010.
- Lan, L., Wargocki, P., Wyon, D.P. and Lian, Z. (2011). Effects of thermal discomfort in an office on perceived air quality, SBS symptoms, physiological responses, and human performance, *Indoor Air*, 21, 376-390.
- Langevine, R. (2006). A decision support system for the maintenance management of buildings (Doctoral dissertation, University of Alberta).
- Lanham III, J. W. (1999). Relating building conditions and classroom conditions to student achievement in Virginia's elementary schools. Unpublished doctoral dissertation, Virginia Polytechnic Institute and State University, Blacksburg, VA.
- Leach, K. (1997). In sync with nature. *School Planning and Management*, 36(4), 32-36.
- Lee, Y. S. (2013). Modeling multiple occupant behaviors in buildings for increased simulation accuracy: An agent-based modeling approach. University of Pennsylvania.
- Leiter, J. (1983). Classroom composition and achievement gains. *Sociology of Education*, 126-132.
- Lemasters, L. K. (1997). A synthesis of studies pertaining to facilities, student achievement, and student behavior (Doctoral dissertation).
- Leung, M. & Fung, I. (2005). Enhancement of classroom facilities of primary schools and its impact on learning behaviors of students. *Facilities*. Vol. 23, No.13/14. Pp. 585-594.
- Levin, H. (1995). Physical factors in the indoor environment. *Occupational Medicine* (Philadelphia, Pa.), 10(1), 59.
- Lewis, M. (2000). Where children learn: Facilities conditions and student test performance in Milwaukee public schools. *CEFPI Issue Trak*, 1-4. www.cefpi.org.
- Lezotte, L. W., & Passalacqua, J. (1978). Individual School Buildings Accounting for Differences in Measured Pupil Performance. *Urban Education*, 13(3), 283-293.

- Li, L., Li, F., Chen, Z., & Sun, L. (2016). Bridge Deterioration Prediction Using Markov-Chain Model Based on the Actual Repair Status in Shanghai. In Transportation Research Board 95th Annual Meeting (No. 16-4744).
- Li, L., Sun, L., & Ning, G. (2014). Deterioration Prediction of Urban Bridges on Network Level Using Markov-Chain Model. *Mathematical Problems in Engineering*, 2014.
- Li, N., Xie, W. C., & Haas, R. (1996). Reliability-based processing of Markov chains for modeling pavement network deterioration. *Transportation Research Record: Journal of the Transportation Research Board*, (1524), 203-213.
- London, W. P. (1987). Full-spectrum classroom light and sickness in pupils. *The Lancet*, 1205-1206.
- Lou, Z., Gunaratne, M., Lu, J. J., & Dietrich, B. (2001). Application of neural network model to forecast short-term pavement crack condition: Florida case study. *Journal of infrastructure systems*, 7(4), 166-171.
- Luke, C. (2007). Equity in Texas public education facilities funding. University of North Texas.
- Lyons, J. B. (2001). Do school facilities really impact a child's education. CEFPI Brief, Issue Trak, 1-6.
- Macal, C. M., & North, M. J. (2005). Tutorial on agent-based modeling and simulation. In *Proceedings of the 37th conference on Winter simulation* (pp. 2-15). Winter Simulation Conference.
- Macal, C. M., & North, M. J. (2009). Agent-based modeling and simulation. In *Winter Simulation Conference* (pp. 86-98). Winter Simulation Conference.
- Macal, C. M., & North, M. J. (2010). Tutorial on agent-based modelling and simulation. *Journal of Simulation*, 4(3), 151-162.
- Macal, C. M., & North, M. J. (2013). Introductory tutorial: Agent-based modeling and simulation. *Simulation Conference (WSC), Proceedings of the 2013 Winter* (pp. 362-376). IEEE.
- Madanat, S., Mishalani, R., and Ibrahim, W. (1995). "Estimation of Infrastructure Transition Probabilities from Condition Rating Data." *J. Infrastruct. Syst.*, 10.1061/(ASCE)1076-0342(1995)1:2(120), 120-125.
- Maier, M. (1998). Architecting Principles for System of Systems. *Systems Engineering* 1 (4): 267–284.
- Malkawi, A. & Augenbroe, G. (2004). *Advanced Building Simulation*. Routledge.

- Maniloff, A. H. (2004). High school size and teachers' perception of working conditions. Unpublished doctoral dissertation, East Carolina University, Greenville, N. C.
- Mauch, M. and Madanat, S. (2001). Semiparametric Hazard Rate Models of Reinforced Concrete Bridge Deck Deterioration. *J. Infrastruct. Syst.*, 10.1061/(ASCE)1076-0342(2001)7:2(49), 49-57
- McGowen, R. S. (2007). The impact of school facilities on student achievement, attendance, behavior, completion rate and teacher turnover rate in selected Texas high schools (Doctoral dissertation, Texas A&M University).
- McGuffey, C. W. (1982). Facilities. W. Herbert (Ed.), Chapter 10: Improving educational standards and productivity (pp. 237-288). Berkeley, CA: McCutchan Publishing Corp.
- Mendel, J. M. (1995). Fuzzy logic systems for engineering: A tutorial. *Proceedings of the IEEE*, 83(3), 345-377.
- Mendell, M. J. & Heath, G. A. (2005). Do indoor pollutants and thermal conditions in schools influence student performance? A critical review of the literature. *Indoor Air* 15(1), 27-52.
- Mendell, M. J., Eliseeva, E. A., Davies, M. M., Spears, M., Lobscheid, A., Fisk, W. J. & Apte, M. G. (2013), Association of classroom ventilation with reduced illness absence: A prospective study in California elementary schools. *Indoor Air*, 23: 515–528. doi: 10.1111/ina.12042.
- Micevski, T., Kuczera, G., & Coombes, P. (2002). Markov model for storm water pipe deterioration. *Journal of infrastructure systems*, 8(2), 49-56.
- Mishalani, R. and Madanat, S. (2002). Computation of Infrastructure Transition Probabilities Using Stochastic Duration Models. *J. Infrastruct. Syst.*, 10.1061/(ASCE)1076-0342(2002)8:4(139), 139-148.
- Mohammed, I. (2015, August). Personal interview.
- Mohessen, S. (2015, September 29). Personal interview.
- Moore, C., Tjioe, M., Manzella, A., Bernhardt, K. S., & McNeil, S. (2007). Agent Models for Asset Management. In *Computing in Civil Engineering: Proceedings of Proceeding of the 2007 ASCE International Workshop on Computing in Civil Engineering* (pp. 176-183).
- Moore, G. T., & Lackney, J. A. (1993). School design: crisis, educational performance and design applications. *Children's Environments*, 99-112.

- Morcous, G. (2006). Performance prediction of bridge deck systems using Markov chains. *Journal of performance of Constructed Facilities*, 20(2), 146-155.
- Morcous, G., & Akhnoukh, A. (2006). Stochastic modeling of infrastructure deterioration: An application to concrete bridge decks. In *Joint International Conference on computing and Decision Making in Civil and Building Engineering*, Montreal, Canada.
- Morcous, G., Rivard, H., & Hanna, A. M. (2002). Modeling bridge deterioration using case-based reasoning. *Journal of Infrastructure Systems*, 8(3), 86-95.
- Moses, C. L. (2001). Improving classroom acoustics: In support of Iowa's comprehensive school improvement initiative. Unpublished doctoral dissertation, Central Michigan University, Mount Pleasant, MI.
- Murrain, P. G. (1983). Administrative determinations concerning facilities utilization and instructional grouping: An analysis of the relationship (s) between selected thermal environments and preferences for temperature, an element of learning style, as they affect word recognition scores of secondary school students (Doctoral dissertation, ProQuest Information & Learning).
- Myhrvold, A. N., Olsen, E., & Lauridsen, O. (1996). Indoor environment in schools - Pupils health and performance in regard to CO2 concentrations. *Indoor Air*, 96(4), 369-371.
- Najafi, M., & Kulandaivel, G. (2005). Pipeline condition prediction using neural network models. In *Proceedings of the American Society of Civil Engineers (ASCE) International Pipeline Conference*, USA.
- National Center for Education Statistics -NCES. (2003). *Facilities Information Management: A Guide for State and Local Education Agencies*, NCES 2003-400, U.S. Department of Education, The Education Facilities Data Task Force. Washington, DC.
- National Research Council. (2006). Review and assessment of the health and productivity benefits of green schools: an interim report. The National Academies Press, Washington, D.C. <http://newton.nap.edu/catalog/11574.html>.
- Nicklas, M. H. & Bailey, G. B. (1995). *Student Performance in Daylit Schools: Analysis of the Performance of Students in Daylit Schools*. Unpublished manuscript of Innovative Design, Raleigh, North Carolina.
- Niemelä, R., Hannula, M., Rautio, S., Reijula, K., & Railio, J. (2002). The effect of air temperature on labour productivity in call centres - a case study. *Energy and Buildings*, 34(8), 759-764.

- Norbäck, D. & Nordström, K. (2008). An experimental study on effects of increased ventilation flow on students' perception of indoor environment in computer classrooms. *Indoor Air*, 18(4), 293-300.
- Norbäck, D., Wålinder, R., Wieslander, G., Smedje, G., Erwall, C., & Venge, P. (2000). Indoor air pollutants in schools: Nasal patency and biomarkers in nasal lavage. *Allergy*, 55(2), 163-170.
- North, M. J., & Macal, C. M. (2007). *Managing business complexity: discovering strategic solutions with agent-based modeling and simulation*. Oxford University Press.
- Nye, B., Hedges, L. V., & Konstantopoulos, S. (2000). The effects of small classes on academic achievement: The results of the Tennessee class size experiment. *American Educational Research Journal*, 37(1), 123-151.
- O'Neill, D. J. (2000). The impact of school facilities on student achievement, behavior, attendance, and teacher turnover rate at selected Texas middle schools in Region XIII ESC. Unpublished doctoral dissertation, Texas A&M University, College Station, TX.
- O'Sullivan, S. (2006). A study of relationship between building conditions and student academic achievement in Pennsylvania's high schools. Unpublished doctoral dissertation, Virginia Polytechnic Institute and State University, Blacksburg, VA.
- Oliff, P. Mai, C. and leachman, M. (2012). new school year brings more cuts in state funding for schools. Center on Budget and Policy Priorities (CBPP). September 4, 2012. www.cbpp.org/files/9-4-12sfj.pdf.
- Osborne, K. F. (2007). Exploring the relationship of teachers' perceptions of the educational suitability of elementary school facilities with student achievement. Doctoral dissertation, Temple University, Philadelphia, PA. Dissertation Abstracts: AAI3268187.
- Osman, H. (2012). Agent-based simulation of urban infrastructure asset management activities. *Automation in Construction*, 28, 45-57.
- Owusu-Ababio, S. (1998). Effect of neural network topology on flexible pavement cracking prediction. *Computer-Aided Civil and Infrastructure Engineering*, 13(5), 349-355.
- Pamoukov, S. (2011). International study program for indoor environmental research. Thesis, University of Nevada, Las Vegas.
- Paradis, R. (2014). Acoustic comfort. National Institute of Building Sciences. <https://www.wbdg.org/resources/acoustic.php>.

- Parsons Corporation & 3D/I. (2006). Facility Condition Assessment for Fergus Falls Public Schools. Fergus Falls, Minnesota. ISD #544.
- Parsons Corporation (2011) Comprehensive Facility Assessment Report for DeKalb County School System.
- Parsons Corporation. (2010a) Comprehensive Facility Assessment Report for Caddo Parish School Board
- Parsons Corporation. (2010b) Ferris State University Facility Condition Assessment Report: 2010 Limited Scope Update
- Parsons Corporation. (2012). Facility Condition Assessment Update for Prince George's County Public Schools.
- Parsons Corporation. (2013a). Dallas Independent School District 2013 Facilities Condition Assessment. <http://www.dallasisd.org>.
- Parsons Corporation. (2013b). Orange Unified School District Facilities Condition Assessment.
- Pavčková, M., Rychtáriková, M., & Tomašovič, P. (2009). Acoustical comfort predictions in classrooms with two simultaneous sound sources. *Slovak Journal of Civil Engineering*, 2, 17-25.
- Peatross F D, Peponis J, (1995), Space, Education and Socialization *Journal of Architectural and Planning Research*. 12:4 Winter, pp. 366-385.
- Pekrun R. , Goetz T. ,Titz W. & Perry R. (2002) Academic Emotions in Students' Self-Regulated Learning and Achievement: A Program of Qualitative and Quantitative Research, *Educational Psychologist*, 37:2, 91-105.
- Peng, S. S. & Wright, D. (1994). Explanation of academic achievement of Asian-American students. *The Journal of Educational Research*, 87(6), 346-352.
- Pepler, D. & Warner, E. (1968). Temperature and learning: an experimental study. *ASHRAE Transactions*, 74(2), 211-219.
- Perez, J., Montano, J., & Perez, J. (2005). Room temperature and its impact on student test scores. Washington, D. C. Council of Educational Facilities Planners.
- Picus, L.O., Marion, S. F., Calvo, N., & Glenn, W.J. (2005). Understanding the relationship between student achievement and the quality of educational facilities: Evidence from Wyoming. *Peabody Journal of Education*, 80, 71-95.

- Pizzo, J. S. (1981). An investigation of the relationship between selected acoustic environments and sound, an element of learning style, as they affect sixth-grade students' reading achievement and attitudes (Doctoral dissertation, ProQuest Information & Learning).
- Ponce-Cruz, P. & Ramírez-Figueroa, F. D. (2009). Intelligent Control Systems with LabVIEW™. Springer Science & Business Media.
- Pritchard, G. W. (1987). Academic achievement and perception of school effectiveness and their relationship to school size. Unpublished doctoral dissertation, South Carolina State University.
- Queensland Department of Housing and Public Works.(2012). Maintenance Management Framework: Building Condition Assessment, Queensland government, [http://www.hpw.qld.gov.au/SiteCollection Documents/MMFBca.pdf](http://www.hpw.qld.gov.au/SiteCollectionDocuments/MMFBca.pdf).
- Quirk, J. (2006).The Facilities Condition Index as a Measure of the Conditions of Public Universities as Perceived by the End Users. Facilities Manager .APPA.September/October. Pp 62-69. http://www.appa.org/files/FMArticles/FM091006_Feature_FCI.pdf.
- Radwan, T. (2016, April 5). Personal interview.
- REHVA - Federation of European Heating and Air-Conditioning Associations. (2010). Ambiente Interior e Eficiência Energética nas Escolas. Ingenium Edições, Lda., Manual REHVA nº13, Lisboa.
- Rich M. & Yaccino S. (2013).Chicago Says It Will Close 54 Public Schools. New York Times. <https://www.nytimes.com/2013/03/22/education/chicago-says-it-will-close-54-public-schools.html>.
- Rivera-Batiz, F. L., & Marti, L. (1995). A School System at Risk: A Study of the Consequences of Overcrowding in New York City Public Schools. IUME Research Report No. 95-1.
- Riveros, G. A., & Arredondo, E. (2014). Predicting Future Deterioration of Hydraulic Steel Structures with Markov Chain and Multivariate Samples of Statistical Distributions. Journal of Applied Mathematics, 2014.
- Rivkin, S. G., Hanushek, E. A., & Kain, J. F. (2005). Teachers, schools, and academic achievement. *Econometrica*, 73(2), 417-458.
- Roberts, L. W. (2009). Measuring school facility conditions: An illustration of the importance of purpose. *Journal of Educational Administration*, 47(3), 368-380.

- Rosenberg, G. G., Blake-Rahter, P., Heavner, J., Allen, L., Redmond, B. M., Phillips, J., & Stigers, K. (1999). Improving Classroom Acoustics (ICA): A Three-Year FM Sound Field Classroom Amplification Study. *Journal of Educational Audiology*, 7, 8-28.
- Sadiq, M. (2015, September). Personal interview.
- Samuels, R. (1999). Light, mood, and performance at school. Final Report. Department of Education and Training and Department of public works and Services. N.S.W., Australia. <http://urbanclimateresearch.org>
- Sanchez-Silva, M., & Rosowsky, D. V. (2008). Biodeterioration of construction materials: state of the art and future challenges. *Journal of Materials in Civil Engineering*, 20(5), 352-365.
- Sanders, W. L. & Rivers, J. C. (1996). Cumulative and residual effects of teachers on future student academic achievement.
- Sanford Bernhardt, K. (2004) An Agent-Based Framework for Modeling Civil Infrastructure Systems Management. *Computational Intelligence*: pp. 16-24. doi: 10.1061/40760(150)2.
- Sanford Bernhardt, K. L., & McNeil, S. (2008). Agent-based modeling: approach for improving infrastructure management. *Journal of Infrastructure Systems*, 14(3), 253-261.
- Scagliotta, E. G. (1980). Falling barometer-Failing behavior. *Academic Therapy*, 15, 607-612.
- Schneider, M. (2002). Do school facilities affect academic outcomes? National Clearinghouse for Educational Facilities. <http://www.ncef.org/pubs/outcomes.pdf>.
- Schoer L. & Shaffran J. (1973). A combined evaluation of three separate research projects on the effects of thermal environment on learning and performance. *ASHRAE Transactions*. Vol 79, 97-108.
- Schuhmacher, N., Ballato, L., & van Geert, P. (2014). Using an agent-based model to simulate the development of risk behaviors during adolescence. *Journal of Artificial Societies and Social Simulation*, 17(3), 1.
- Schulte, R., Bridges, B., & Grimsrud, D. (2005). Continuous IAQ monitoring. *ASHRAE Journal*, 47(5), 38.
- Seppanen, O. A. & Fisk, W. J. (2004), Summary of human responses to ventilation. *Indoor Air*, 14: 102–118. doi: 10.1111/j.1600-0668.2004.00279.x.
- Seppanen, O. A., & Fisk, W. (2006). Some quantitative relations between indoor environmental quality and work performance or health. *HVAC&R Research*, 12(4), 957-973.

- Seppanen, O., Fisk, W. J., & Faulkner, D. (2003). Cost-benefit analysis of the night-time ventilative cooling in office buildings. Lawrence Berkeley National Laboratory.
- Seppanen, O., Fisk, W. J., & Faulkner, D. (2004). Control of temperature for health and productivity in offices. Lawrence Berkeley National Laboratory.
- Seppanen, O., Fisk, W., & Lei, Q. (2006). Effect of temperature on task performance in office environment. Lawrence Berkeley National Laboratory. Retrieved from: <http://escholarship.org/uc/item/45g4n3rv>.
- Setunge, S., & Hasan, M. S. (2011). Concrete Bridge Deterioration Prediction using Markov Chain Approach. ICSECM 2011 - Kandy - Sri Lanka.
- Sharma, S., & Gupta, R. (2016). Soft Computing Applications in Infrastructure Management. Imperial Journal of Interdisciplinary Research, 2(7).
- Shaughnessy, R. J., Haverinen-Shaughnessy, U., Nevalainen, A. & Moschandreas, D. (2006), A preliminary study on the association between ventilation rates in classrooms and student performance. *Indoor Air*, 16: 465–468. doi: 10.1111/j.1600-0668.2006.00440.x.
- Shekharan, A. (1998). Effect of noisy data on pavement performance prediction by artificial neural networks. *Transportation Research Record: Journal of the Transportation Research Board*, (1643), 7-13.
- Shekharan, A. (2000). Solution of pavement deterioration equations by genetic algorithms. *Transportation Research Record: Journal of the Transportation Research Board*, (1699), 101-106.
- Shelter, M. (2013). “2013 State of Our Schools: Report from the Center for Green Schools at USGBC Calls for Immediate Examination of America’s School Facilities” U.S. Green Building Council.
- Shendell, D. G., Prill, R., Fisk, W. J., Apte, M. G., Blake, D., & Faulkner, D. (2004). Associations between classroom CO₂ concentrations and student attendance in Washington and Idaho. *Indoor air*, 14(5), 333-341.
- Sirin, S. R. (2005). Socioeconomic status and academic achievement: A meta-analytic review of research. *Review of Educational Research*, 75(3), 417-453.
- Smedje, G., & Norbäck, D. (2000). New ventilation systems at select schools in Sweden—effects on asthma and exposure. *Archives of Environmental Health: An International Journal*, 55(1), 18-25.

- Smedje, G., Norbäck, D., & Edling, C. (1997). Asthma among secondary school children in relation to the school environment. *Clinical & Experimental Allergy*, 27(11), 1270-1278.
- Smith, S. M. (2008). School building quality and student performance in South Carolina public high schools: A structural equation model (Doctoral dissertation, Clemson University).
- Sokolowski, J., & Banks, C. (2011). Principles of modeling and simulation: a multidisciplinary approach. John Wiley & Sons.
- Stapleton, D. B. (2001). Differences in school climate between old and new buildings: Perceptions of parents, staff and students. Unpublished doctoral dissertation, Georgia Southern University, Statesboro, GA.
- Stevenson, K. R. (2001). The relationship of school facilities conditions to selected student achievement outcomes: A study of South Carolina Schools. University of South Carolina, Columbia, SC. Department of Educational Leadership and Policy Studies.
- Strauss, A. (2016). Numerical and monitoring based Markov Chain approaches for the fatigue life prediction of concrete structures. *Engineering Structures*, 112, 265-273.
- Swift, D. (2000). Effects of student population density on academic achievement in Georgia elementary schools. Doctoral dissertation, University of Georgia, Dissertation abstracts, AAI9994129.
- Sydoriak, D. E. (1984). An experiment to determine the effects of light and color in the learning environment. Unpublished doctoral dissertation, University of Arkansas, Fayetteville.
- Syverson, M. S. (2005). The relationship between Indiana high school building conditions and ISTEP math/English scores in Indiana high schools. Unpublished doctoral dissertation, Indiana State University, Terre Haute, IA. Dissertation abstracts.
- Tanabe, S. I., Nishihara, N., & Haneda, M. (2007). Indoor temperature, productivity, and fatigue in office tasks. *HVAC&R Research*, 13(4), 623-633.
- Taylor, A. (2009). Linking Architecture and Education: Sustainable Design for Learning Environments. Albuquerque: University of New Mexico Press.
- Teicholz, E., & IFMA Foundation. (2012). Technology for facility managers: The impact of cutting-edge technology on facility management. Hoboken, New Jersey: John Wiley & Sons, Inc.
- Tham, K. W. (2004). Effects of temperature and outdoor air supply rate on the performance of call center operators in the tropics. *Indoor aAr*, 14(s7), 119-125.

- Thornton, J. C. (2006). School building condition and student achievement of minority and economically challenged students in Virginia. Unpublished doctoral dissertation, Virginia Polytechnic Institute and State University, Blacksburg, VA.
- Tilsley, A. (2017). Subtracting Schools from Communities. Retrieved June 13, 2018, from <https://www.urban.org/features/subtracting-schools-communities>.
- Torres, a. (2013). Modelling the future water infrastructure of cities. master thesis, Delft University of Technology.
- Toyinbo, O. (2012). Indoor Environmental Quality in Finnish Elementary Schools and Its Effects on Students' Health and Learning.
- Turunen, M., Toyinbo, O., Putus, T., Nevalainen, A., Shaughnessy, R., & Haverinen-Shaughnessy, U. (2014). Indoor environmental quality in school buildings and the health and wellbeing of students. *International Journal of Hygiene and Environmental Health*.
- U.S. Department of Education, National Center for Education Statistics.(2000) Condition of America's Public School Facilities: 1999. NCES 2000-032, by Laurie Lewis, Kyle Snow, Elizabeth Farris, Becky Smerdon, Stephanie Cronen, and Jessica Kaplan. Bernie Greene, project officer. Washington, DC.
- U.S. EIA. (2008) Major Fuel Consumption by End Use for Non-Mall Buildings. <https://www.eia.gov/consumption/commercial/data/2003/pdf/e1-e11.pdf>.
- U.S. EPA (2003) Indoor Air Quality & Student Performance, EPA Report 402-K-03-006. www.ashkingroup.com/pdfs/Education/EPA%20iaq_and_student_performance.pdf.
- United States Environmental Protection Agency (U.S. EPA). (2009). Indoor Air Quality Tools for School Coordinator's Guide: A Guide to Implementing an IAQ Program. Publication # EPA 402/K-07/008.
- United States General Accounting Office. (1995a). Conditions of America's schools. (Report No. GAO/HEHS-95-61 Publication No. B-259307). Washington, DC.
- Urquhart, T. (2006). Incorporating Condition Assessment into a Comprehensive Asset Management Program. *Proceedings of the Water Environment Federation*, 2006(8), 4198-4206.
- USEPA. (2016). An Introduction to Indoor Air Quality. Retrieved November 17, 2016, from <https://www.epa.gov/indoor-air-quality-iaq/introduction-indoor-air-quality>.
- Uzarski, D. R., & Grussing, M. N. (2008). Building condition assessment metrics: Best practices.

- Vilatarsana, G. (2004). The environmental noise exposure of schools around Heathrow.M.Sc. Dissertation, South Bank University. www.whyverne.co.uk/acoustics/pages/pdf/gael.pdf.
- Waldron, T. (2012). 26 States Cut Their Education Budgets For This School Year. Center for American Progress Action Fund. September 4, 2012.
- Wang, L. & Hong, T. (2013). Modeling and simulation of HVAC faulty operations and performance degradation due to maintenance issues. In ASim 2012-1st Asia Conference of International Building Performance Simulation Association, Shanghai, China.
- Wang, L. (2014) Modeling and simulation of HVAC faulty operations and performance degradation due to maintenance issues. In ASim 2012-1st Asia conference of International Building Performance Simulation Association, Shanghai, China, 11/25/12-11/27/12.
- Wargo, J.(2003) The physical school environment: An essential component of a health-promoting school, Information Series on School Health, World Health Organization, Geneva. http://www.who.int/school_youth_health/media/en/physical_sch_environment.pdf.
- Wargoeki, P. & Wyon, D. P. (2007). The effects of moderately raised classroom temperatures and classroom ventilation rate on the performance of schoolwork by children (RP-1257). HVAC&R Research, 13(2), 193-220.
- Wargoeki, P. & Wyon, D. P. (2007). The effects of outdoor air supply rate and supply air filter condition in classrooms on the performance of schoolwork by children (RP-1257). HVAC&R Research, 13(2), 165-191.
- Wargoeki, P. & Wyon, D. P. (2013). Providing better thermal and air quality conditions in school classrooms would be cost-effective. Building and Environment, 59, 581-589.
- Wargoeki, P., Wyon, D. P., Matysiak, B., & Irgens, S. (2005). The effects of classroom air temperature and outdoor air supply rate on performance of schoolwork by children. Technical University of Denmark: International Centre for Indoor Environment and Energy.
- Wargoeki, P., Wyon, D. P., Sundell, J., Clausen, G. & Fanger, P. O. (2000), The effects of outdoor air supply rate in an office on perceived air quality, sick building syndrome (SBS) symptoms and productivity. Indoor Air, 10: 222–236. doi: 10.1034/j.1600-0668.2000.010004222.x.

- Wargoeki, P., Wyon, D.P. & Fanger, P.O. (2000) Pollution source control and ventilation improve health, comfort and productivity. Proceedings of the Conference “Cold Climate HVAC 2000,” Sapporo, Japan, 445–450.
- Wargoeki, P., Wyon, D.P. & Fanger, P.O. (2000) Productivity is affected by the air quality in offices. Proceedings of the Healthy Buildings 2000 Conference, Helsinki, 1, 635–640. Helsinki, Finland: SIY Indoor Air.
- Wargoeki, P., Wyon, D.P., Nielsen, J.B. & Fanger, P.O. (2002) Call-centre occupant response to new and used filters at two outdoor air supply rates. Proceedings of Indoor Air 2002, Monterey, the 9th International Conference on Indoor Air Quality and Climate, 3,449–454, Monterey: ISIAQ.
- Wei, W. (2003). An investigation into the relationship between daylighting quality for school buildings in Hong Kong, China. Unpublished doctoral dissertation, Chinese University of Hong Kong, People’s Republic of China.
- Weinstein, C. S. (1979). The physical environment of school: A review of research. Review of Educational Research. 49(4), 577-610.
- Wellalage, N. K. W., Zhang, T., & Dwight, R. (2014). Calibrating Markov Chain–Based Deterioration Models for Predicting Future Conditions of Railway Bridge Elements. Journal of Bridge Engineering, 20(2), 04014060.
- Wellalage, N. W., Zhang, T., Dwight, R., & El-Akruti, K. (2015). Bridge deterioration modeling by Markov Chain Monte Carlo (MCMC) simulation method. In Engineering Asset Management-Systems, Professional Practices and Certification (pp. 545-556). Springer International Publishing.
- Wicks, G. M. (2005). A study of the relationship among new school buildings and student academic performance and school climate in Mississippi. Doctoral dissertation. Mississippi State University, Dissertation abstracts, AAI3223347.
- Wight & Company, Magellan Consulting, DeJONG, & AECOM (2009).Facilities Conditions and Educational Facility Assessment Summary: School District U-46 Elgin, Illinois.
- Williams, D. (2013). School district announces \$304M shortfall. The Philadelphia Tribune.[http://www.phillytrib.com/newsarticles/item/8746-school-district-announces-\\$304m-shortfall.html](http://www.phillytrib.com/newsarticles/item/8746-school-district-announces-$304m-shortfall.html).

- Williamson, E. A. (1998). Relationship among school size, self-esteem, and achievement in Missouri high schools. Unpublished doctoral Dissertation. University of Missouri. Columbia, Missouri. Dissertation Abstracts International. 59 (08), 2918.
- Witterseh, T., Wyon, D.P., & Clausen, G. (2004). The effects of moderate heat stress and open-plan office noise distraction on SBS symptoms and on the performance of office work. *Indoor Air*, 14(s8), 30-40.
- Wohlfarth, H. (1986). Color and light effects on students' achievement, behavior, and physiology. Alberta Education.(Edmonton: Planning Services Branch).
- Wyon, D.P (1991). The ergonomics of healthy buildings: Overcoming barriers to productivity. In IAQ'91: Post Conference Proceedings. Atlanta, Ga.: American Society of Heating, Refrigerating, and Air-Conditioning Engineers, Inc. (pp. 43-46).
- Wyon, D.P. & Wargocki, P. (2006). Room Temperature Effects on Office Work (pp. 181-192). London: Taylor & Francis.
- Wyon, D.P., Andersen, I., & Lundqvist, G. (1979). The effects of moderate heat stress on mental performance. *Scandinavian Journal of Work, Environment & Health*, 5(4), 352-361.
- Yang, J., Lu, J. J., Gunaratne, M., & Xiang, Q. (2003). Overall pavement condition forecasting using neural networks—an application to Florida Highway Network. In 82nd annual meeting of the transportation research board.
- Yang, Y., Kumaraswamy, M., Pam, H., and Xie, H. (2013). "Integrating Semiparametric and Parametric Models in Survival Analysis of Bridge Element Deterioration." *J. Infrastruct. Syst.*, 10.1061/(ASCE)IS.1943-555X.0000115, 176-185.
- Yielding, A. C. (1994). Interface between educational facilities and learning climate in three Northern Alabama NK-2 elementary schools (kindergarten, second-grade). Unpublished doctoral dissertation, The University of Alabama.
- Zadeh, L. A. (1965). Fuzzy sets. *Information and Control*, 8(3), 338-353.
- Zentall, S. S., & Shaw, J. H. (1980). Effects of classroom noise on performance and activity of second-grade hyperactive and control children. *Journal of Educational Psychology*, 72(6), 830.
- Zhang, X. (2006). Markov-based optimization model for building facilities management. *Journal of construction engineering and management*, 132(11), 1203-1211.

- Zhao, E. (2011). K-12 Education Funding: Most States At Levels Lower Than Pre-Recession, Cut Spending This Year. The Huffington Post. www.huffingtonpost.com/2011/10/07/k-12-education-funding-mo_n_1000396.html.
- Zheng, H., Son, Y. J., Chiu, Y. C., Head, L., Feng, Y., Xi, H., ... & Hickman, M. (2013). A primer for agent-based simulation and modeling in transportation applications (No. FHWA-HRT-13-054).

VITA

Education

- 1993-1997 B.Sc. in Civil Engineering- Kuwait University**
- 1997-2000 Master's Degree in civil engineering- Kuwait University**
Research topic: Web Based Construction Education.
- 2005 - 2008 Master's Degree in information technology (Systems) Kuwait University**
Research topic: An XML-Based Budgeting Approach for Public Construction projects in Kuwait.
- 2010-2018 Doctor of Philosophy (Ph.D.) in Civil Engineering Purdue University**
Research topic: an overall policy decision-support system for Educational facilities management: An agent-based approach

Work Experience

- 1998 - 2003** Kuwait's Ministry of Planning –Head section in Budget department
- 2003-2010** Kuwait University – Construction Program (KUCP), Project Coordinator

Awards/Honors

- Amir's Award for Excellent Academic Performance (Kuwait - 1998, 2001, & 2009)

Published papers

- 1- Instructor's Guideline for web-Based Construction Education. May 2002
K. Al-Reshaid, N. Kartam, and H. Al-Bader
Computers and Advanced Technology in Education Conference.
IASTED - Cancun, Mexico.
- 2- A project control process in pre-construction phases: Focus on effective methodology. Aug 2005
Khaled Al-Reshaid, Nabil Kartam, Narendra Tewari, Haya Al-Bader
Engineering, Construction and Architectural Management Journal
Volume: 12 Issue: 4 Page: 351 – 372
- 3- An XML-based budgeting approach for public construction projects: case study from Kuwait. June 2011
Khaled Al-Reshaid, & Haya Al-Bader
Kuwait Journal of science and engineering
Volume :38, Issue: 1, 2011
- 4- An agent-based framework of a Maintenance Budget Allocation System for Educational Facilities. June 2013
Haya Albader, & Amr Kandil
CSCE 2013 general conference